

TURRI + monica armani

ROMA
capsule collection

ROMA
capsule collection

TURRI[®] + monica armani
The Italian way to beauty

Turri and Monica Armani meet



EN Turri has created a transversal fil rouge of trends embracing a contemporary style, as it increasingly seeks to address the demands of younger generations.

The brand's collaboration with Monica Armani breathed life and international flair into Turri's new capsule collection, Roma, which strikes an ideal balance of aesthetics, innovation, technology and tradition. Roma represents equally the designer's stylistic code and the well-honed execution of the Turri company.

The element most characteristic of the collection is the round arch – a synthesis of perfection and harmony found frequently in the Eternal City. Counterbalancing the continuous reference to these arches and the know-how of the Turri brand is Monica Armani's recognisable aesthetic, which together create an exclusive relationship.

IT *Turri e Monica Armani si incontrano.*

Turri, sempre più attenta alle richieste delle nuove generazioni, è riuscita a creare un fil-rouge trasversale di tendenze capace di abbracciare un gusto più contemporaneo.

Da qui l'incontro con l'International style di Monica Armani che ha dato vita alla nuova capsule collection Roma in cui è percepibile l'equilibrio perfetto tra estetica e innovazione, tra tecnologia e tradizione, tipico della cifra stilistica della designer italiana e altrettanto condiviso dal saper fare dell'azienda Turri.

Come in un viaggio nella città eterna da cui prende nome, tra gli archetipi dell'architettura italiana, il primo elemento che contraddistingue l'intera collezione è l'arco a tutto sesto, sintesi di perfezione e armonia.

Il continuo riferimento ai caratteri distintivi e al know-how del marchio Turri viene bilanciato dalla linea riconoscibile di Monica Armani creando una relazione esclusiva.

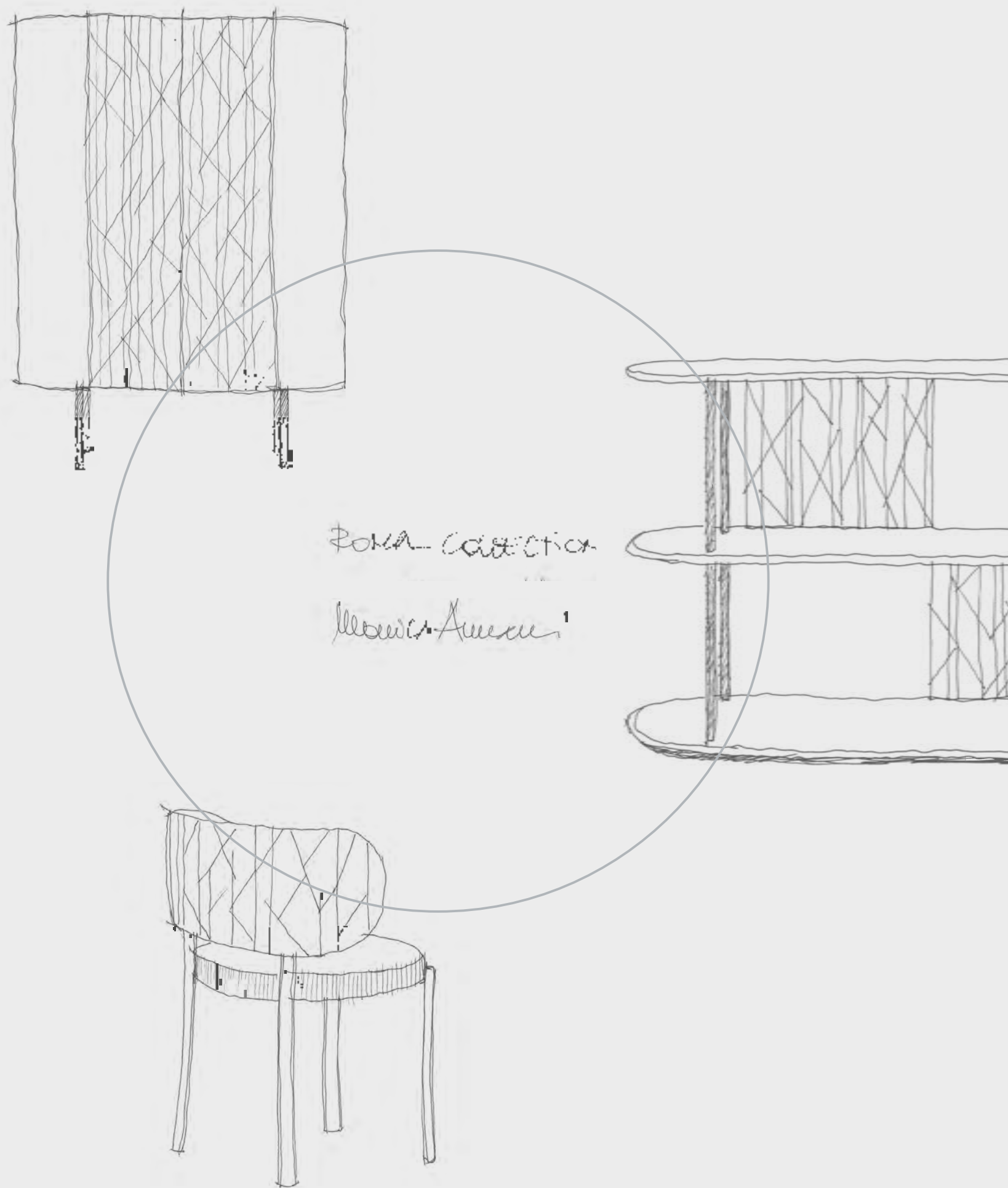

ROMA capsule collection

“Elegant, refined and seductive in its simplicity, the Roma collection plays on the balance between precious surfaces and the precision of shapes.” — Monica Armani

EN Roma, with its soft and rounded lines, shows its innovative DNA in the choice and use of fine materials. The historic ability of the Turri brand to create lacquered surfaces finds its maximum expression in Roma. The collection features precious fabrics and embroidered leathers, as well as geometric prints that are applied to the doors of products as unique as they are timeless.

Straight and round lines chase each other, connecting to create unique objects born from the union of historical memory and contemporaneity - explains Monica Armani.

The semicircular section formed by the arch, the cornerstone of this collection, defines a wide range of furnishings for the living and sleeping areas.

IT *“Elegante ma curata, seducente nella sua semplicità, la collezione ROMA gioca sull’equilibrio tra superfici preziose e la precisione del segno” - Monica Armani*

Roma, con le sue linee morbide e tondeggianti, mostra il suo DNA innovativo nella scelta e nell’uso di materiali pregiati. La storica abilità del marchio Turri nella realizzazione di superfici laccate trova in Roma la sua massima espressione: alla contemporaneità della stampa geometrica applicata alle ante dei prodotti si aggiunge la combinazione di tessuti preziosi e pelli ricamate che raccontano un design singolare e senza tempo.

Linee rette e tonde si inseguono, si raccordano per creare oggetti unici nati dall’unione di memoria storica e contemporaneità - racconta Monica Armani

La sezione semicircolare, unica e completa, disegnata dall’arco, elemento cardine di questa collezione, definisce un’ampia gamma di arredi per la zona living e notte.

Roma reveals its versatility through two worlds — one traditional and romantic and the other of a more modern, dynamic spirit.

EN Roma reveals its versatility through two worlds — one traditional and romantic and the other of a more modern, dynamic spirit.

Monica Armani tells the story of the Roma collection using two locations: a prestigious Parisian apartment with classic architectural features and a Miami penthouse — a modern, refined space with double-height ceilings and a cosmopolitan atmosphere.

With the choice of two distinct locations, the designer showcases Roma's extreme versatility. Appropriate for a wide range of furnishing projects, objects from the collection harmonise with any architectural style, while imprinting a strong identity.

Modernity and tradition join hands in the soul of the Roma collection, creating a family of furnishings that embody the artisan tradition of Turri and the diversity of Monica Armani's designs.

IT Roma racconta la sua versatilità attraverso due mondi, uno fatto di tradizione e romanticismo, l'altro dallo spirito moderno e dinamico.

Monica Armani racconta la collezione Roma attraverso due location, un prestigioso appartamento Parigino, dalle caratteristiche architettoniche tipiche degli edifici classici e una penthouse in Miami, una location moderna e raffinata, dalla doppia altezza e dallo spirito internazionale.

Con la scelta di due location dallo stile così differente, la designer vuole mostrare l'estrema versatilità degli arredi Roma, oggetti collocabili in progetti d'arredo eterogenei, in grado di imprimere una forte identità all'interno, dialogando armoniosamente con qualunque stile architettonico.

Modernità e tradizione si fondono nell'anima della collezione Roma, creando una famiglia di arredi che racchiude in sé la tradizione artigianale di Turri e l'internazionalità del design di Monica Armani.



PARISIAN apartment

p. 08 - 39



MIAMI penthouse

p. 40 - 79



PARISIAN apartment

EN To tell the story of Monica Armani's new Roma capsule collection, we will journey to beautiful Paris.

This prestigious Parisian apartment, boasting the ample spaciousness typical of 19th century houses, is decorated with boiserie and stucco. It is furnished with pieces from the Roma collection, dressed up in forest green colour mood board.

An exclusive space, with characteristic features, meets the new Roma collection by Monica Armani for Turri.

Elegant and timeless interior design, which confirms the DNA of this new creation by Monica Armani for Turri, is an expression of perfect balance between shapes and finishes.

Each piece of furniture in the collection influences the space around it, creating a contemporary living room, silent but at the same time impactful, striking a balance between modernity and tradition.

IT Per raccontare la nuova capsule collection Roma di Monica Armani, abbiamo scelto un ideale viaggio a Parigi.

Un prestigioso appartamento parigino con la caratteristica spazialità delle case dell'800, decorato con boiserie e stucchi, è arredato con i pezzi della collezione Roma vestiti con il mood board Forest.

Una location importante, dai tratti caratteristici, incontra la nuova collezione Roma di Monica Armani per Turri.

Un interior design elegante e senza tempo, che conferma il DNA di questa nuova creazione di Monica Armani per Turri, un'espressione in perfetto equilibrio tra segno, forme e finiture.

Ogni arredo della collezione è capace di dialogare con gli spazi, creando un living contemporaneo, silente ma allo stesso tempo protagonista, in equilibrio tra modernità e tradizione.



EN The dining room, with unmistakable features of Parisian interior design, is furnished with the rectangular Roma table, made from a single material and expertly lacquered by Turri in its signature style and quality.

The Roma chairs, with their formal balance and lightness, become the protagonists and perfectly complement the furniture.

IT La sala da pranzo di questa location, con i tratti inconfondibili degli interior design tipici della città, è arredata con il tavolo rettangolare Roma, monomaterico, sapientemente laccato da Turri con la sua proverbiale qualità.

Le sedie Roma con il loro equilibrio formale, la loro leggerezza, diventano protagoniste, il perfetto complemento dell'arredo.





ROMA table

EN The Roma table, rectangular with a rounded design, boasts a top with rounded corners and cylindrical legs. It is made entirely of single-color lacquered wood.

IT Il tavolo Roma, rettangolare ma dal design tondeggiante, ha un top dagli angoli arrotondati e gambe cilindriche, ed è realizzato interamente in legno laccato monocolor.



EN Roma chairs, with smooth or embroidered backrests in fabric or leather, again reference the thematic arches. The same line and customisation possibilities exist for the Lounge Roma armchair.

IT Le sedie Roma con lo schienale liscio o ricamato, rivestite in tessuto o pelle, esprimono il riferimento all'arco a tutto sesto a cui si ispira l'intera collezione soprattutto nella forma a pianta tonda. Stessa linea e stesse possibilità di personalizzazione anche per la poltroncina Lounge Roma.



ROMA chair



EN The large oval Roma carpet highlights the dining area pieces. It is completed by cabinets exhibiting precise balance between architecture and form, thanks to the precious materials chosen by the master craftsmen of Turri.

The Roma mirror crowns the sideboard with its vibrant decoration on the doors, a distinctive feature created by Monica Armani for this collection.

IT Il grande tappeto ovale Roma sottolinea i pezzi per la zona pranzo, completata da contenitori in perfetto equilibrio tra architettura e forma, preziosi grazie ai materiali lavorati dai maestri artigiani di Turri.

Lo specchio Roma incorona il sideboard con il suo decoro vibrante sulle ante, tratto distintivo creato da Monica Armani per questa collezione.







ROMA sideboard

EN The geometric element that characterizes the cabinet appears as well on the sideboard, which was designed to have wooden or glass doors. The wooden version can be customized with a printed geometric decoration.

IT Seguendo la linea di tutta la zona giorno, la credenza è stata pensata per avere ante in legno o in vetro, e nella versione in legno può essere personalizzata con un decoro geometrico stampato.

EN The cabinets are the main characters of the Roma collection. They blend functionality and aesthetics in an equilibrium of arched shapes and linear textures, perfectly completing the interior design of this apartment. The cabinets' versatility is expressed through their customisation options and their use as elements either in the center of the room or aligned along the walls.

IT I contenitori sono i veri protagonisti della collezione Roma, fondono funzionalità ed estetica in un equilibrio fatto di forme ad arco e texture lineari. La versatilità di questi si racconta attraverso la loro personalizzazione, utilizzabili come elementi da centro stanza o accostati alle pareti completano perfettamente il progetto di interior di questo appartamento.





ROMA vitrine

EN On the cabinet's wooden doors is a geometric decoration that can be printed on a single-color lacquered finish, with the possibility of maintaining the sides in curved wood covered in leather.

This customisable and versatile piece, within which are four glass shelves, comes with doors that can be made of glass or wood (with or without decoration).

IT La decorazione geometrica sulle ante in legno del cabinet può essere stampata su finitura laccata monocolora, mantenendo la possibilità dei fianchi in legno curvato rivestiti in pelle.

La versatilità di questo prodotto è dettata principalmente dalle ante che possono essere realizzate in legno – con o senza decoro – o in vetro, e che al loro interno ospitano quattro ripiani in vetro trasparente.







ROMA round table

EN Roma round table confirms the circular theme of the capsule in its legs and top. It features a singular metal base of vertical tubes (available in Champagne Gold and Graphite Gray finishes) with a round top in marble or monocolour lacquered wood.

IT Il tavolo rotondo Roma conferma il pensiero circolare dell'intera capsule nella presenza delle gambe e del piano d'appoggio, è caratterizzato da una singolare base in metallo composta da tubolari verticali (disponibili nelle finiture Champagne Gold e Graphite Grey), con top rotondo in marmo o legno laccato monocolore.



EN In this large office with grand arched windows, the Roma round table, with a marble top, flawlessly combines with the reed structure in Champagne Gold finish. With their circular bases and enveloping backrests, the Roma chairs and the disc-shaped carpet splendidly complete this space.

IT Nel grande office con le ampie vetrate ad arco, il tavolo rotondo Roma con piano in marmo combinato con la struttura a canne in finitura Champagne Gold. Le sedie Roma con la loro pianta rotonda e gli schienali avvolgenti, insieme al tappeto rotondo, sono perfettamente ambientati.





ROMA chair

EN Roma chairs can be upholstered in leather or fabric. The backrest can be made in plain upholstery or with the characteristic embroidered texture.

IT Le sedie Roma possono essere rivestite in pelle o tessuto. Lo schienale può essere realizzato liscio, oppure con la caratteristica texture ricamata.



EN In front of the window, framed by the light, is the Roma desk. In this small private space, the Roma desk looks especially sophisticated and elegant.

IT Davanti alla finestra, quasi incorniciato dalla luce, si trova lo scrittoio Roma, raccolto in un piccolo spazio privato, sofisticato ed elegante.





ROMA desk

EN The Roma collection also features a small and elegant writing desk. A balanced object, the volumes of the drawers seem to float in the void. Equally functional and graceful, the Roma desk is suitable for many contemporary environments.

IT Nella collezione Roma anche un piccolo e sofisticato scrittoio. Un oggetto bilanciato, i volumi dei cassetti sembrano appesi e galleggiano nel vuoto. Funzionalità ed eleganza per Roma desk, adatto alle tante situazioni dell'interior design contemporaneo.



MIAMI penthouse

EN After the Parisian apartment, we will head to Miami for the next chapter of Monica Armani's new Roma capsule collection.

This contemporary and exclusive penthouse, with large windows and double-height ceilings, is furnished with the Roma collection, according to an ocean-themed mood board.

In this location, the Roma collection presents all its glamour, born from the encounter between Turri and Monica Armani's international style. The harmony of aesthetics, innovation, technology and tradition emblematic of the Italian designer's stylistic code is strongly evident in this penthouse.

IT Per raccontare la nuova capsule collection Roma di Monica Armani, abbiamo scelto, dopo l'appartamento parigino, una location a Miami.

Una penthouse contemporanea ed esclusiva, con grandi vetrate e spazi a doppia altezza, arredata con gli arredi della collezione Roma vestiti dal mood board Ocean.

La collezione Roma in questa location esprime tutto il suo glamour, nata dall'incontro tra Turri e l'International style di Monica Armani, esprime in modo percepibile l'equilibrio perfetto tra estetica e innovazione, tra tecnologia e tradizione, elementi tipici della cifra stilistica della designer italiana, elementi che in questa penthouse ritrovano la loro perfetta espressione.



EN In this sunny environment, the unmistakable architecture of the étagère takes centre stage.

IT In questo ambiente solare, l'architettura inconfondibile dell'étagère diventa protagonista.



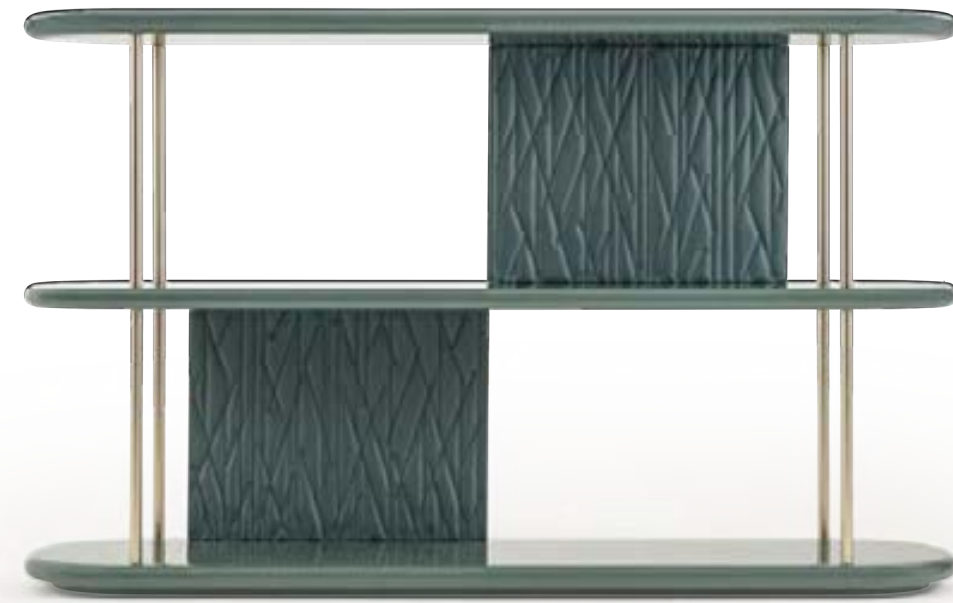

ROMA étagère

EN The tops of the étagère, made of single-color glossy lacquered wood, are vertically arranged on the back, along with padded panels that can be upholstered in leather and then embroidered. The vertical metal structure of the étagère is available in two types of finishes.

IT I piani dell'étagère, realizzati in legno laccato lucido monocolore, sul retro sono intervallati verticalmente da pannelli imbottiti che possono essere foderati in pelle e ricamanti. La struttura verticale in metallo dell'étagère è disponibile nelle due varianti di finitura.



EN The dining area, distinguished by liberal spaciousness, is the ideal setting for the rectangular table and the Roma chairs, which are placed on the collection's large oval carpet.

IT La zona pranzo, caratterizzata da una spazialità importante, è il perfetto scenario per il tavolo rettangolare e le sedie Roma, posati sul grande tappeto ovale della collezione.







ROMA rectangular table

EN The Roma rectangular table can be made with a metal base in Graphite Gray or Champagne Gold finishes.

IT Il tavolo rettangolare Roma può essere realizzato con base in metallo nelle finiture Graphite Grey o Champagne Gold.

EN In this ethereal environment, where architectural design combines quality materials with careful attention to detail, the Roma collection creates a space for relaxation and contemplation. The armchairs, the original table lamp, and the mirror are placed on the round Roma carpet, forming a quintessential setting for modern penthouse living.

IT In questo ambiente etereo, espressione di una architettura che combina matericità e qualità dei dettagli, la collezione Roma crea uno spazio per il relax e la contemplazione dell'intorno. Sul tappeto rotondo Roma sono posate le poltroncine, l'originale tavolino lampada e lo specchio, un perfetto set per una moderna penthouse.





ROMA mirror

EN The Roma mirror fills an impressive diameter. This bronzed mirror is bordered by a glossy, lacquered wooded frame.

IT Lo specchio Roma ha un diametro importante, con cornice in legno laccato lucido e specchio bronzato.



ROMA side table

EN In the Roma collection a jolly product in two versions, side table with an integrated lamp and side table. The side table can be understood as a coffee table and / or lamp, finding home in the lounge-living area or bedroom. This semicircular table is made entirely of metal and is available in Champagne Gold or Graphite Grey finishes.

IT Nella collezione Roma un prodotto jolly in due versioni, tavolino con lampada integrata ad arco e tavolino. Questi oggetti possono essere collocati in tante situazioni sia nella zona giorno che nella notte. Il tavolino è realizzato interamente in metallo nelle finiture Champagne Gold o Graphite Grey.







EN On the mezzanine, the Roma bed is in the centre of a large and open sleeping area, dividing the space nicely with its double-sided headboard. By partitioning the room, the headboard creates a secluded area for extra coziness and privacy.

IT Sul mezzanino una grande zona notte open space con al centro il letto Roma che divide lo spazio, grazie alla sua testiera bifacciale. Si crea così un "piccolo luogo" protetto da dedicare a sé stessi.



EN In the sleeping area of the Roma collection, the bed plays a fundamental role. It is made with a wing structure and can be completely covered in either fabric or leather, both for the headboard and the bed frame. The side wings can be embroidered in the collection's signature style.

IT Nella zona notte della collezione Roma svolge un ruolo fondamentale il letto, realizzato con una struttura ad ali totalmente rivestito in tessuto o pelle, sia nella testiera che nel giroletto. Le ali laterali possono essere realizzati con ricamo, nella caratteristica texture della collezione.



ROMA bed



EN Two Roma chests of drawers and matching mirrors complete the bedroom's back wall and blend in seamlessly with the space.

IT La quinta di fondo della zona notte viene completata dai due comò Roma e dallo specchio coordinato della collezione. Due elementi in equilibrio che dialogano perfettamente nello spazio.





ROMA chest of drawers

EN The Roma chest of drawers is an elegant element dedicated to the sleeping area. The sides are covered in leather, and the handles are crated from stylish leather straps. The Roma chest of drawers is available in two versions: with four drawers or with a shelf.

IT Il comò Roma è un elemento elegante dedicato alla zona notte. I fianchi sono rivestiti in pelle e le maniglie sono create da eleganti fettucce anch'esse in pelle.

Il comò Roma è disponibile nella versione a quattro cassetti o con ripiano.





ROMA bedside table

EN The Roma bedside table has a curvy form, in accordance with the collection's defining shapes. The drawer integrates perfectly with the structure, and the shelf almost appears to be levitating, lending an extreme lightness to the design.

IT Il comodino Roma ha una forma rotonda che segue il trend delle forme dell'intera collezione. Il cassetto si integra perfettamente alla struttura, il ripiano è quasi sospeso donando estrema leggerezza al design.

EN The headboard and its corresponding paneling at the foot of the frame create a livable area all around the Roma bed. Behind the headboard, one finds an exquisite space for beauty with its coordinating pouf, as well as easy access to the wardrobe.

IT Sul retro del letto, vivibile nella sua totalità, si ricava un perfetto spazio per il beauty con il pouf coordinato. La quinta creata dalla testiera del letto dialoga con la boiserie della doppia profondità creando l'accesso al guardaroba.



EN Roma beauty is available with or without a mirror, with a top in lacquered wood and side suspended drawer units covered in leather. The metal legs return to the dressing table, as a distinctive thread throughout the entire collection

IT Il beauty Roma è disponibile con o senza specchio, con top in legno laccato e cassettiere laterali sospese rivestite in pelle, nella toilette beauty tornano anche le gambe in metallo come linea distintiva dell'intera collezione.



ROMA beauty





ROMA pouf

EN Designed to be combined with beauty, the fully-padded and leather-covered pouf brings back the geometric decoration typical of the capsule.

IT Pensato per essere abbinato al beauty, il pouf completamente imbottito e rivestito in pelle, riporta il decoro geometrico tipico della capsule.





ROMA objects

EN Roma objects are precious and versatile decorative elements with a stylized design, they are made of Verde Alpi or Calacatta Oro marble.

IT Gli oggetti Roma sono elementi decorativi preziosi e versatili dal design stilizzato, sono realizzati in marmo Verde Alpi o Calacatta Oro.



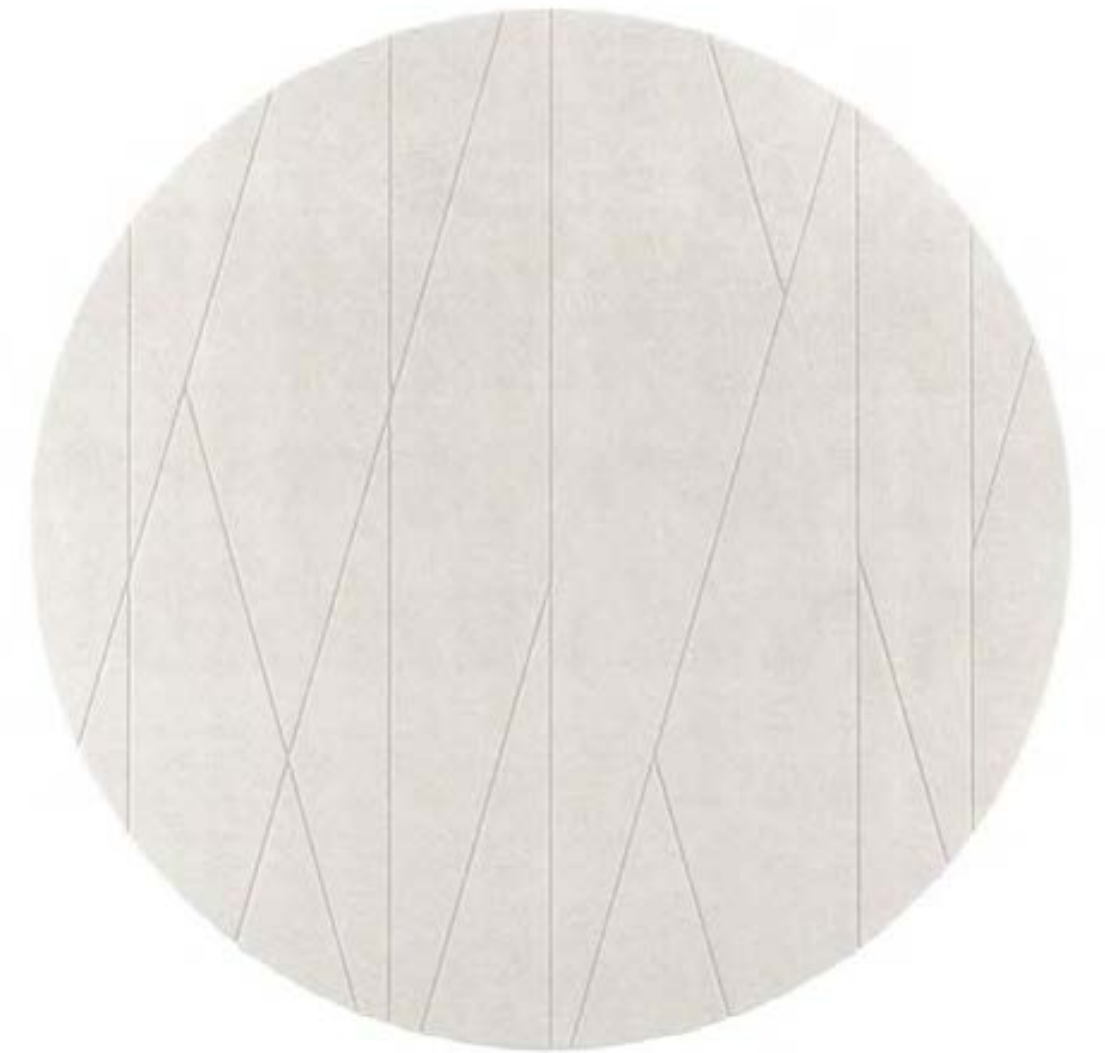
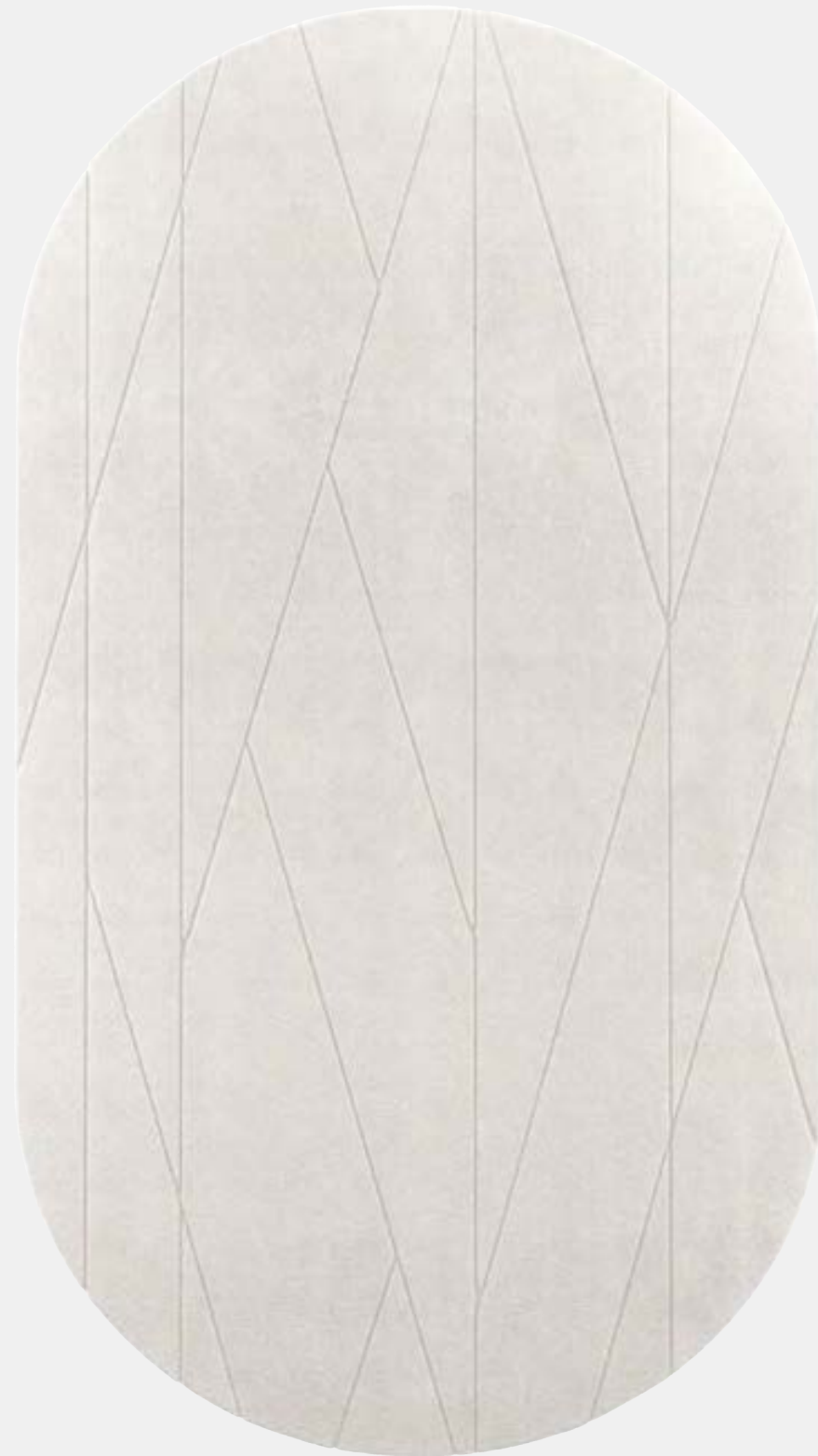

ROMA carpets

EN Roma carpets follow the stylized shapes that are the leitmotif of the entire collection. Made of Botanical Silk, these accessories are suitable for creating a warm atmosphere.

IT I tappeti Roma seguono le forme stilizzate che fanno da fil-rouge all'intera collezione. Realizzati in Seta Botanica, sono accessori adatti a creare una calda atmosfera.



MOOD BOARD

The prevailing spirit of an environment stems directly from the elements within it. Monica Armani presents the following six inspirational mood boards, which have defined the stories and themes underlying each housing project.

L'impronta identitaria di un ambiente deriva anche dalla scelta dei materiali. Monica Armani presenta sei mood boards per dare spazio al personale racconto di ogni progetto abitativo.

SNOW

Nordic tone-on-tone colors create fresh atmospheres.

Cromie nordiche tono su tono creano fresche atmosfere.

SAND

Beige and brown are combined with refined red shades.

Beige e marrone si abbinano a raffinate tonalità mattone.

PEARL

Pearly tones with elegant orange contrasts.

Toni perlati con eleganti contrasti aranciati.

VULCAN

Anthracite gray and natural stones combine in organic balance.

Grigio antracite e pietre naturali si abbinano in naturale equilibrio

FOREST

The green hues of the forest create harmony and peace.

Il colore della natura per creare armonia e pace.

OCEAN

Deep blue tones accented by sparkling white.

Toni di blu profondo, e tocchi di bianco spimeggiante.

MOOD BOARD

SNOW



○ 764/A



○ 770/A



○ 206M



○ 765/A

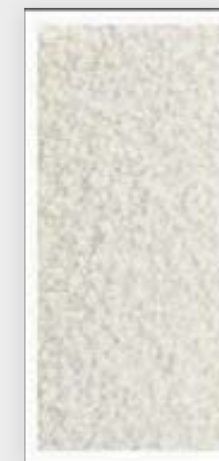

LLBN01

Glossy white rose lacquered
Laccato bianco rosato lucido

206M

Calacatta Oro

1294P

Leather
Pelle

764/A

Velvet
Velluto

765/A

Bouclé fabric
Tessuto bouclé

770/A

Fabric
Tessuto

○ 1294P



○ LLBN01



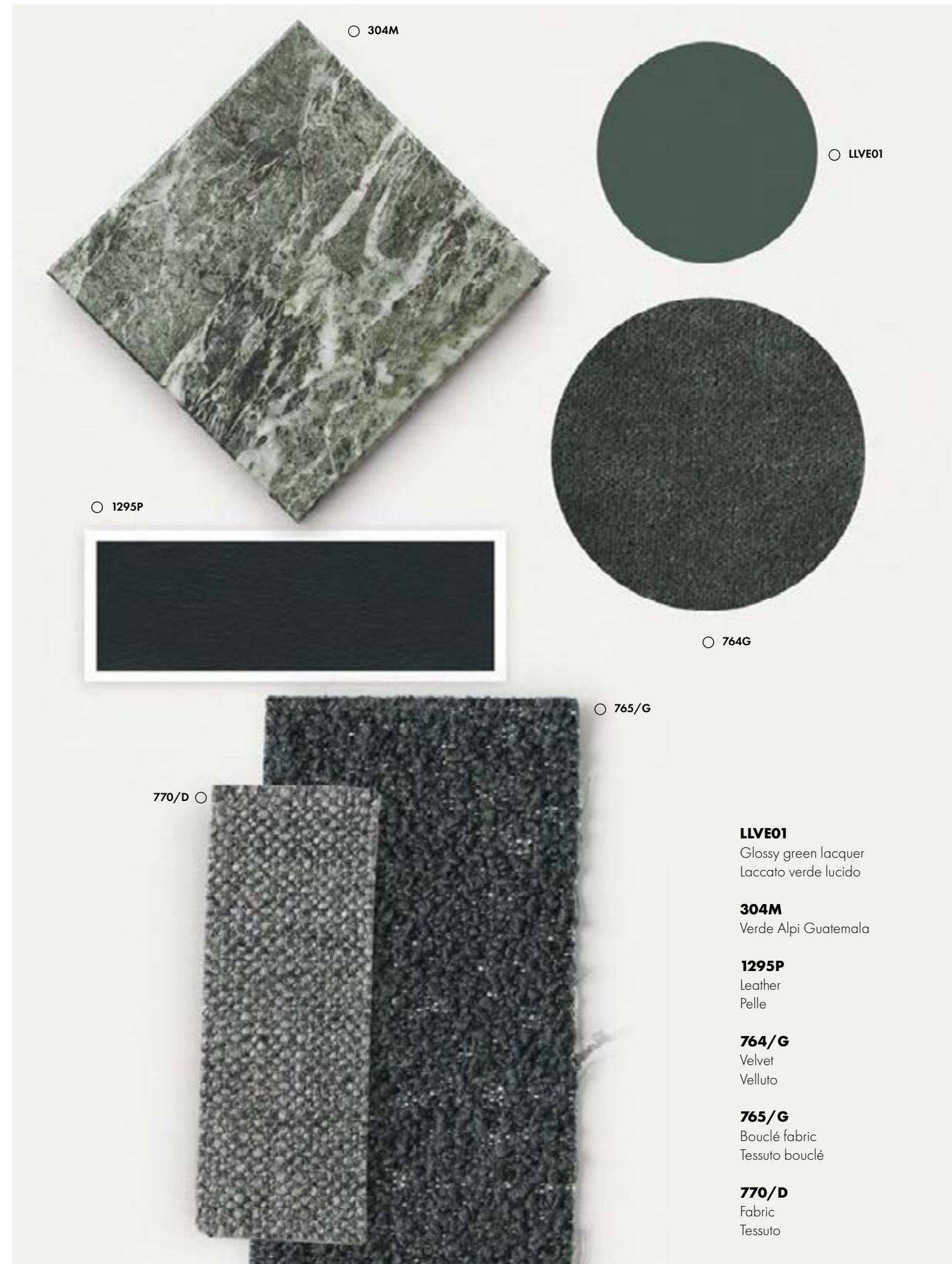

○ 304M

○ LLVE01

○ 1295P

○ 764/G

○ 765/G

770/D ○

LLVE01

Glossy green lacquer
Laccato verde lucido

304M

Verde Alpi Guatemala

1295P

Leather
Pelle

764/G

Velvet
Velluto

765/G

Bouclé fabric
Tessuto bouclé

770/D

Fabric
Tessuto

MOOD BOARD
FOREST

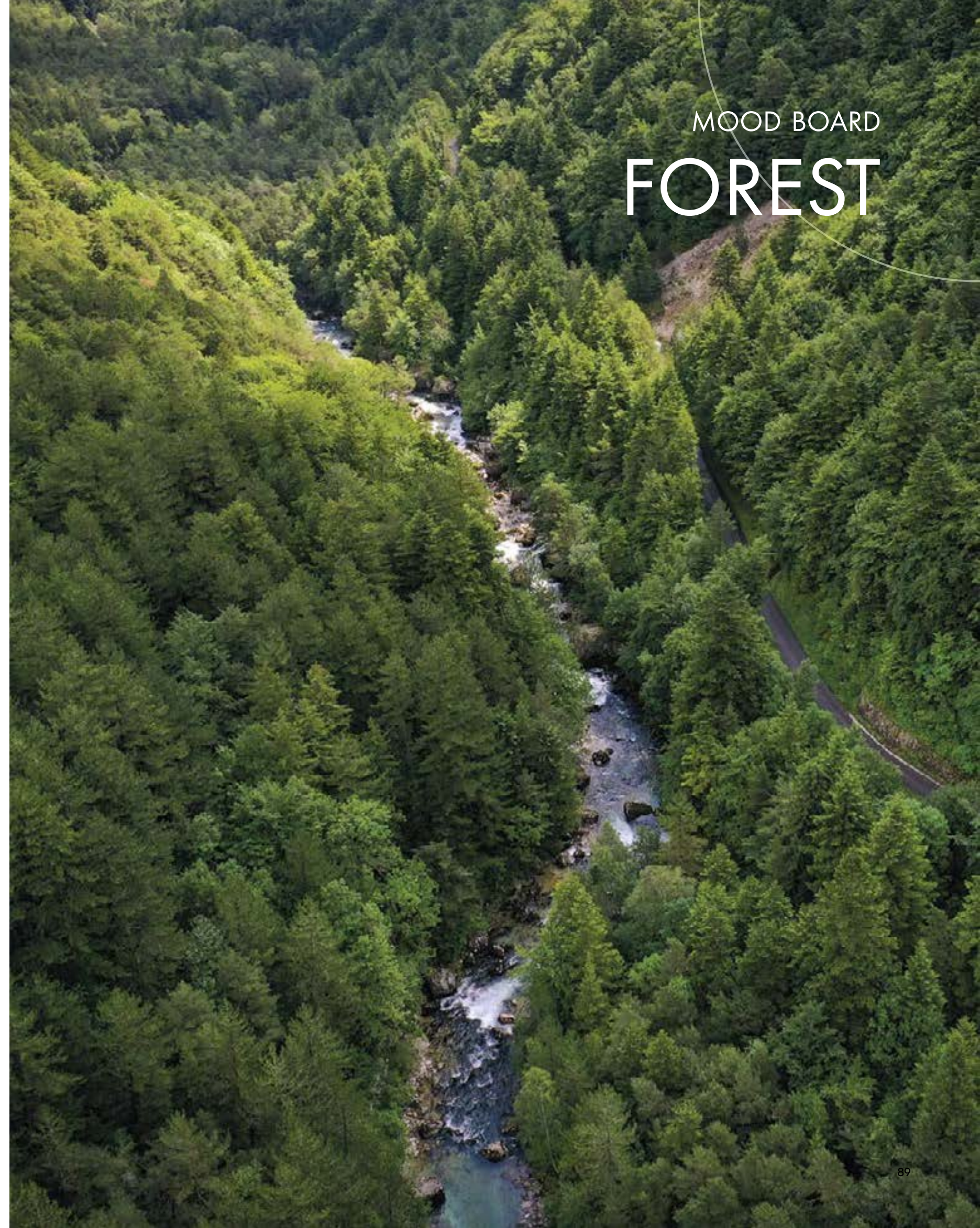

MOOD BOARD

VULCAN



○ 1045P

○ 400M

○ LLGR03

○ 765/F

○ 764/E

○ 770/F

LLGR03

Glossy dark grey lacquered
Laccato grigio scuro lucido

400M

Bianco Carrara

1045P

Leather
Pelle

764/E

Velvet
Velluto

765/F

Bouclé fabric
Tessuto bouclé

770/F

Fabric
Tessuto

MOOD BOARD

PEARL



LLGR04 ○

○ 726/F

○ 770/C

○ 1212P

○ 206M

○ 765/I

LLGR04
Glossy warm grey lacquer
Laccato grigio caldo lucido

206M
Calacatta Oro

1212P
Leather
Pelle

726/F
Velvet
Velluto

765/I
Bouclé fabric
Tessuto bouclé

770/C
Fabric
Tessuto



LLBL01 ○

○ 1291P

765/A ○

○ 701/N

○ 770/G

○ 400M

LLBL01
Glossy blue lacquered
Laccato blu lucido

400M
Bianco Carrara

1291P
Leather
Pelle

701/N
Velvet
Velluto

765/A
Bouclé fabric
Tessuto bouclé

770/G
Fabric
Tessuto

MOOD BOARD
OCEAN

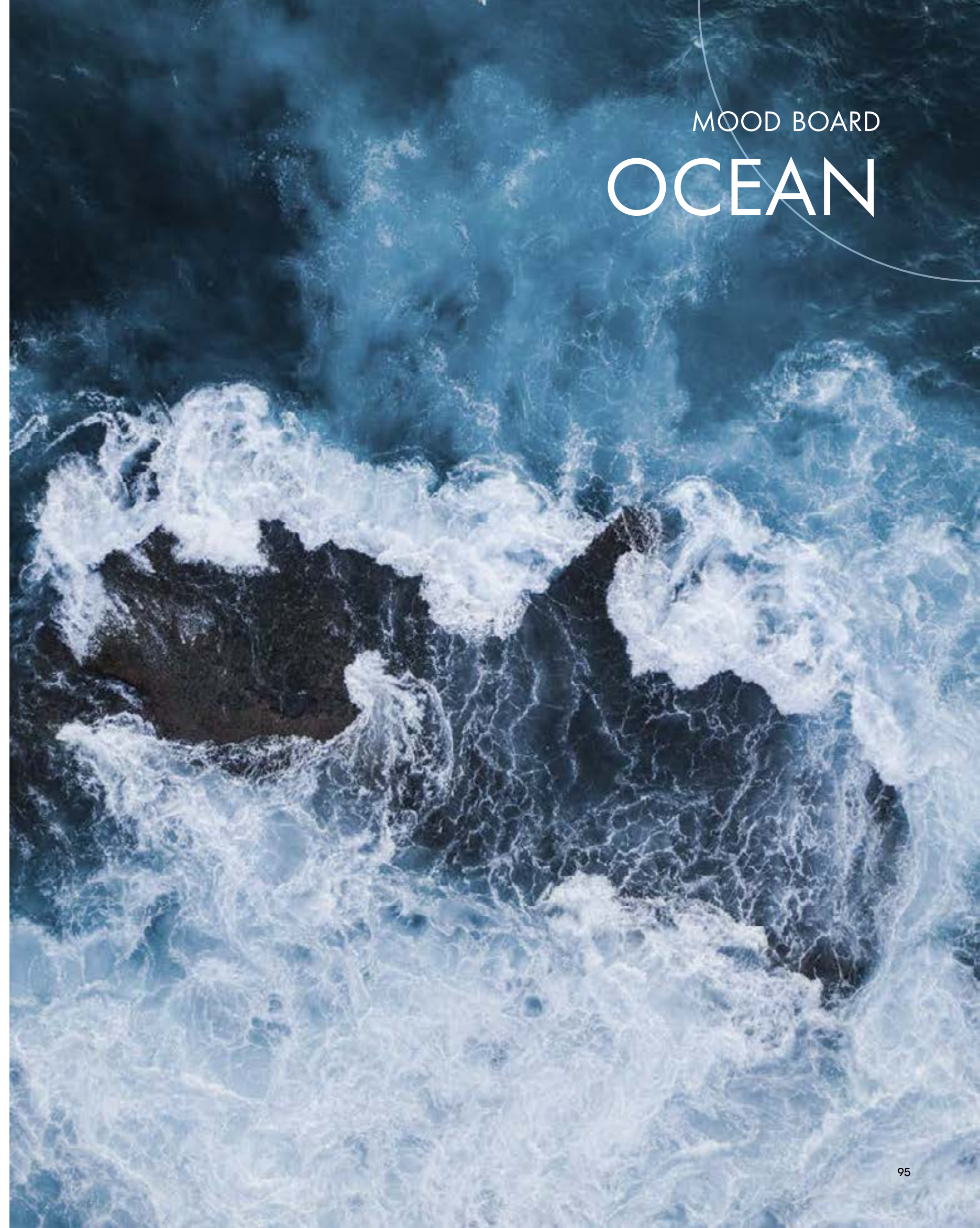

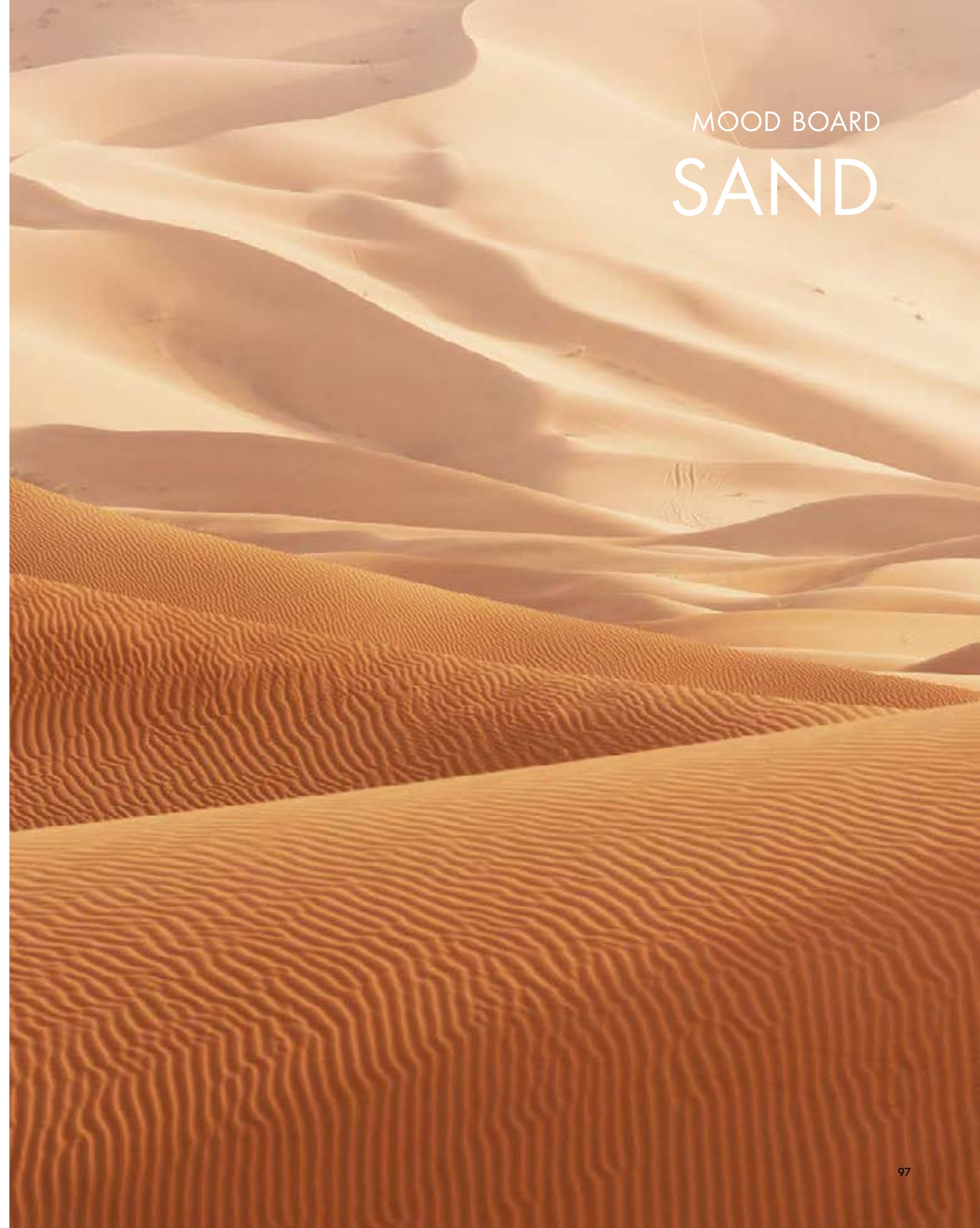
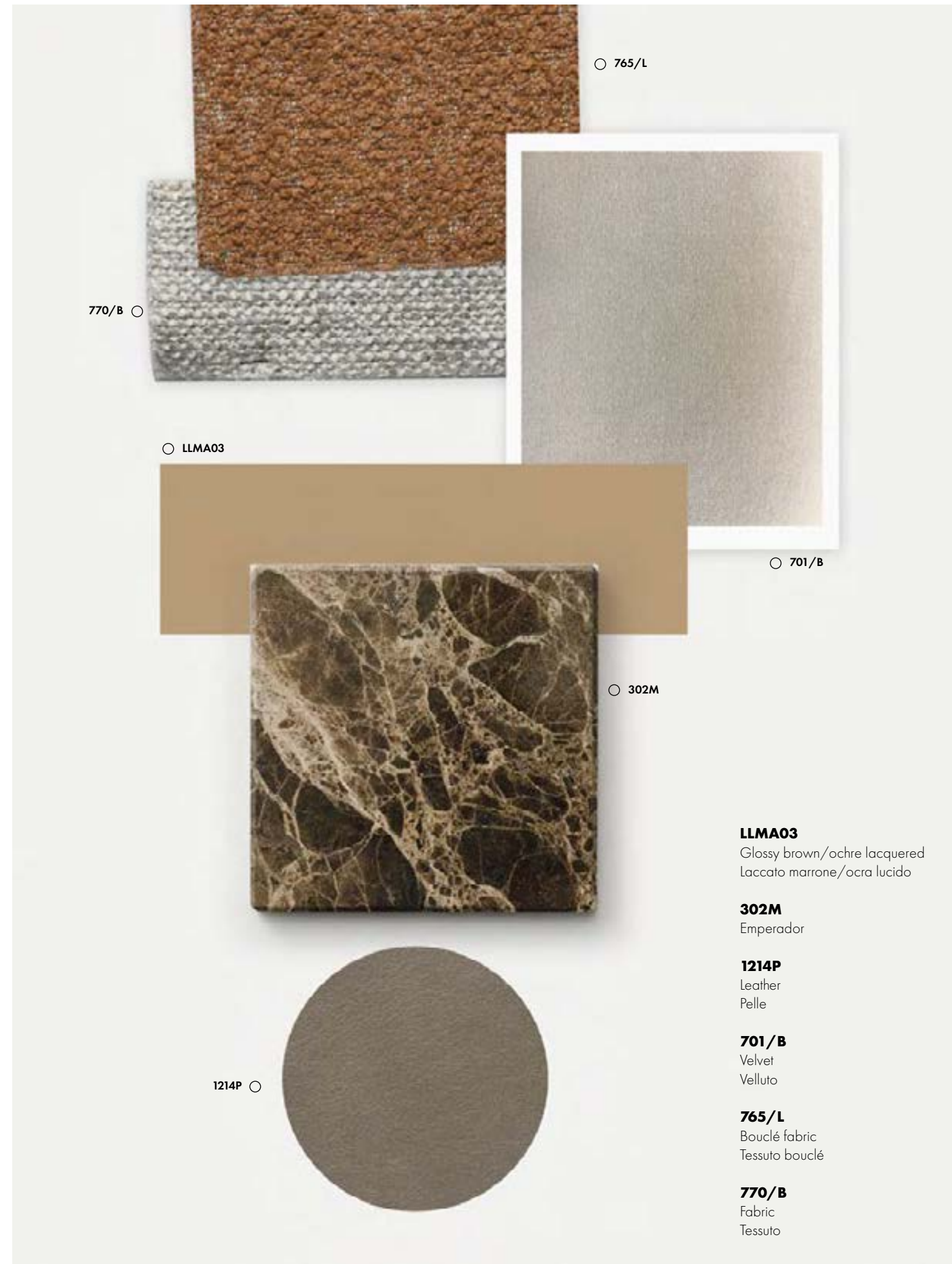

TECHNICAL

FINISHING

Wooden structure glossy monochrome lacquered polyester finish.

UPHOLSTERED ITEMS

Leathers used on our items are all natural leathers: they can be plain or patterned. Any imperfections and/or colour changes from leather to leather or from batch to batch are not to be considered as a fault since they represent the typical characteristic of the leather itself. The natural variations of colors stimulated by artificial of natural lights, the minimal dimensional variations caused by un-common levels of humidity or dryness, and in general other natural features of the upholstery coverings, do not have to be considered defects. For leathers and hides, all the natural marks, wrinkliness, different levels of gleam and shade, spots and general imperfections, folds due to the natural expansion or movement during use, do not have to be considered defects but elements which featured a natural product and its authenticity. In some cases (particularly for light colors), these features are more evident, because the technique for tanning them stresses the naturalness of the product and it doesn't cover it with painting or printing. The features of some types of fabrics are related to their composition or way of production and do not have to be considered defects. For example, we describe: "interference pattern effect", "dark-light effect", "stain effect", "imprint effect on velvets and chinilles. In fabrics, leathers and hides, each batch of production can have minimal variations of tones, in comparison both to the samples sets and to items which have been produced in different periods. A proper use of the products and a proper maintenance of upholsteries, allow to preserve their quality in time. We recommend to cover the Velcro areas during washing, so that these parts cannot damage or scratch the fabrics. The upholstered parts, particularly the ones with covering in feather, are more inclined to folds or crumples, due to common use. The furniture can only be produced with plain and smooth leathers without decorative patterns. For any selection of leathers (or fabrics), different from the above stated specifications, Turri will confirm if possible to produce and the related price increase if required.

CARPETS

Turri carpets are totally hand-knotted on a loom and made of wool and silk in different percentages from model to model. Release of fibers is possible due to the typical characteristic of the material and for this reason it has to be considered a value and a guarantee of the product.

REMARKS

All finishes, woods, fabrics and leathers in the photos of this catalogue are provided just as an indication of the colours. The furniture are hand-made decorated and the leather and wood are a natural materials. For this reason, possible differences in the colours between the photos and the produced furniture must be considered acceptable. TURRI reserves the right to make all the changes considered necessary to improve the products without any previous notice.

FINITURE

Struttura in legno laccato monocoloro poliestere lucido.

IMBOTTITI

Rivestimenti: Le pelli utilizzate sui nostri prodotti sono tutte pelli naturali: possono essere lisce oppure stampate con motivi particolari. Eventuali segni o imperfezioni sono da considerarsi una caratteristica della vera pelle e non ne sminuiscono il pregio, ma ne esaltano la naturale bellezza e autenticità. Non possono essere considerati difetti la variazione naturale di tonalità dei colori sollecitati da luci ambientali o artificiali, le minime variazioni dimensionali determinate da tassi anomali di umidità o secchezza, ed in generale altre caratteristiche naturali dei rivestimenti. Per quanto riguarda pelle e cuoio, eventuali segni naturali, rugosità, diverso grado di lucentezza e tonalità, punti ed imperfezioni in genere, pieghe dovute alla normale dilatazione durante l'uso non sono da considerarsi difetti, ma elementi che caratterizzano un prodotto naturale e la sua autenticità. In alcuni casi (soprattutto nei colori chiari) tali caratteristiche sono particolarmente presenti, in quanto il tipo di conciatura di questi pellami tende ad evidenziare la naturalezza del prodotto e non a coprirlo con la verniciatura o la stampa a pressione. Alcune tipologie di tessuto presentano caratteristiche dovute alla composizione ed al tipo di lavorazione, che non sono da considerarsi difettosità. A puro titolo esemplificativo, citiamo: "effetto a macchia" o "marezzatura", l'"effetto chiaro/scuro" e l'"effetto impronta di velluti e ciniglie. Nei tessuti, nelle pelli e nei cuoi, ogni lotto di produzione può presentare variazioni minime di tonalità, sia rispetto al campionario, sia rispetto ad elementi prodotti in tempi diversi. Un corretto utilizzo dei prodotti ed una corretta manutenzione dei rivestimenti, permettono di mantenere la qualità degli stessi nel tempo. Si raccomanda di coprire le parti rigide del velcro durante i lavaggi dei rivestimenti, in modo che queste non vadano a graffiare o a danneggiare i tessuti. Le parti imbottite, soprattutto quelle con il prerivestimento in piuma, sono soggette a stropicciature e pieghe nel rivestimento, legate anche al normale utilizzo. I mobili e gli imbottiti possono essere prodotti unicamente con pelli lisce senza lavorazioni e/o disegni decorativi. In caso di scelta di pelli (e/o tessuti) diversi da quanto sopra specificato, la Turri si riserva la facoltà di verificarne la fattibilità e di comunicare l'eventuale aumento di prezzo ove necessario.

TAPPETI

I tappeti Turri sono totalmente annodati a mano su telaio e composti, in percentuali differenti da modello a modello, da lana e seta. Il rilascio di fibre è dovuto alle caratteristiche tipiche dei materiali di cui i tappeti sono composti, e per questa ragione non ne sminuisce il pregio ma è da considerare garanzia del valore del prodotto.

NOTE

I colori di tutte le finiture, i legni, i tessuti, le pelli e i marmi, presentati nelle foto di questo catalogo sono da intendere come puramente indicativi. Le laccature, i tessuti e le pelli possono subire leggere variazioni di tono di colore, le essenze e la pelle sono materiali naturali. Per questi motivi, eventuali differenze di colore tra le foto e i mobili prodotti devono essere considerati accettabili. TURRI si riserva il diritto di apportare tutte le modifiche ritenute necessarie per migliorare i prodotti senza alcun preavviso.

More info

Tables	100-101
Chairs	102-103
Small armchair	104
Side table	105
Sideboards	106
Cabinet/Vitrine	107
Etagere	108
Bed	109
Chest of drawers	110
Bedside table	111
Beauty	112
Pouf	113
Carpets	114
Objects	115
Finishes	116-119

Structure: MDF, glossy monochrome lacquered polyester finish.

Struttura: MDF, finitura laccato monocoloro poliestere lucido

A125

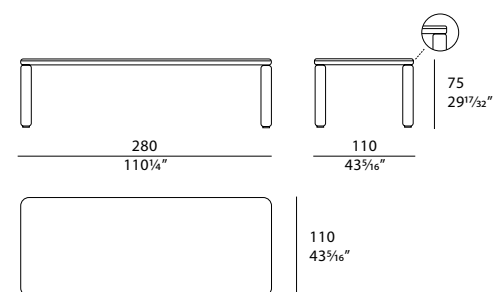

A124

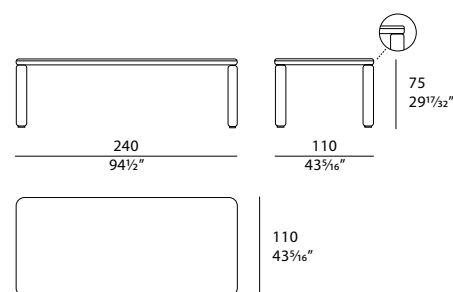

Finishes of photographed items / Riferimenti fotografici finiture



A125 / LLVE01

Rectangular table.
Wooden structure glass polyester finish green colour laquered LLVE01.

Tavolo rettangolare.
Struttura in legno laccato poliestere lucido finitura color verde LLVE01.

p. 10-11 / 13



A125 / LLBN01

Rectangular table.
Wooden structure glass polyester finish pinkish white colour laquered LLBN01.

Tavolo rettangolare.
Struttura in legno laccato poliestere lucido finitura color bianco rosato LLBN01.

p. 14-15

Top: A122 - A120 available in two option: MDF, glossy monochrome lacquered polyester finish or marble. A121 - A123 available in three option: MDF, glossy monochrome lacquered polyester finish, marble or glass / Base: Metal, Champagne Gold or Graphite Grey finish.

Top: A122 - A120 disponibili in due varianti: MDF, finitura laccato monocoloro poliestere lucido, o marmo. A121 - A123 disponibile in tre varianti: MDF, finitura laccato monocoloro poliestere lucido, marmo o in vetro / Base: metallo finitura Champagne Gold o Graphite grey.

A122
Table with wooden top
A122M
Table with marble top

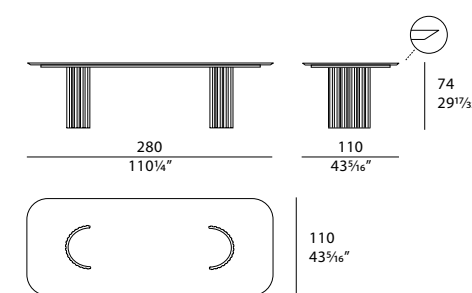

A120
Table with wooden top
A120M
Table with marble top

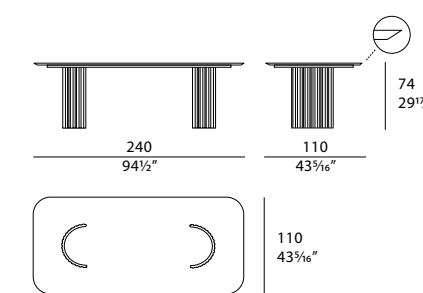

A121
Table with wooden top
A121V
Table with glass top
A121M
Table with marble top

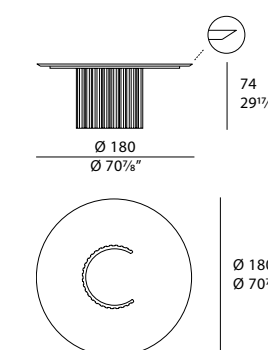

A123
Table with wooden top
A123V
Table with glass top
A123M
Table with marble top

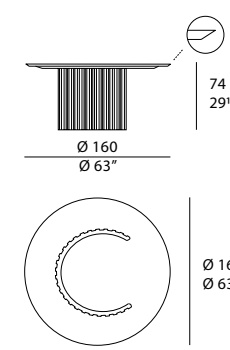

Finishes of photographed items / Riferimenti fotografici finiture



A122 / LLBN01 - Graphite Grey

Rectangular table with wooden top.
Wooden structure glass polyester finish pinkish white colour laquered LLBN01. Graphite Grey metal base.

Tavolo rettangolare con top in legno.
Struttura in legno laccato poliestere lucido finitura color bianco rosato LLBN01. Base in metallo Graphite Grey.

p. 50-51 / 52-53



A122 / LLBN01 - Champagne Gold

Rectangular table with wooden top.
Wooden structure glass polyester finish pinkish white colour laquered LLBN01. Champagne Gold metal base.

Tavolo rettangolare con top in legno.
Struttura in legno laccato poliestere lucido finitura color bianco rosato LLBN01. Base in metallo Champagne Gold.

p. 42-43 / 49



A121M / 206M cat 02 - Champagne Gold

Round table with marble top.
Calacatta Oro marble top 206M cat. 02. Champagne Gold metal base.

Tavolo rotondo con top in marmo.
Top in marmo Calacatta Oro 206M cat. 02. Base in metallo Champagne Gold.

p. 30-31



A121M / 302M cat 03 - Champagne Gold

Round table with marble top.
Emperador marble top 302M cat. 03. Champagne Gold metal base.

Tavolo rotondo con top in marmo.
Top in marmo Emperador 302M cat. 03. Base in metallo Champagne Gold.

p. 28-29 / 33

Structure: metal and curved plywood / **Seat cushion and backrest:** Polyurethane foam in different densities / **Pre-upholstery:** polyester wadding / **Upholstery:** non-removable in fabric or leather. Available with embroidery or plain back / **Legs:** metal in Champagne Gold or Graphite Grey finish.

Struttura: metallo e multistrato curvato / **Cuscino seduta e schienale:** Poliuretano espanso a quote differenziate / **Prerivestimento:** ovatta di poliestere / **Rivestimento:** non removibile in tessuto o pelle. Schienale disponibile con o senza ricamo / **Gambe:** metallo finitura Champagne Gold o Graphite Grey.

A130

Chair with plain back

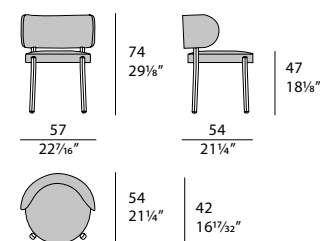

A130R

Chair with embroidered back

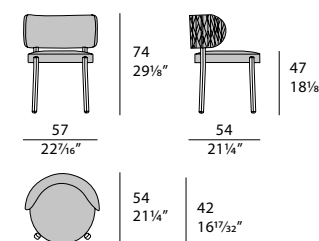

Finishes of photographed items / Riferimenti fotografici finiture



A130R / 1295P cat. LH - Champagne Gold

p. 10-11 / 13

Chair with embroidered back.
Wooden structure covered in leather 1295P cat. LH. Metal legs in Champagne Gold finish.

Sedia con schienale ricamato.
Struttura in legno rivestita in pelle 1295P cat. LH. Gambe in metallo finitura Champagne Gold.



A130 / 1295P cat. LH - Champagne Gold

p. 10-11 / 13 / 19

Chair.
Wooden structure covered in leather 1295P cat. LH. Metal legs in Champagne Gold finish.

Sedia.
Struttura in legno rivestita in pelle 1295P cat. LH. Gambe in metallo finitura Champagne Gold.



A130 / 765/A cat. T - Champagne Gold

p. 16-17 / 49 / 61 / 65

Chair.
Wooden structure covered in fabric 765/A cat. T. Metal legs in Champagne Gold finish.

Sedia.
Struttura in legno rivestita in tessuto 765/A cat. T. Gambe in metallo finitura Champagne Gold.



A130 / 765/1 cat. T - Champagne Gold

p. 28-29 / 33 / 37

Chair.
Wooden structure covered in fabric 765/1 cat. T. Metal legs in Champagne Gold finish.

Sedia.
Struttura in legno rivestita in tessuto 765/1 cat. T. Gambe in metallo finitura Champagne Gold.

Finishes of photographed items / Riferimenti fotografici finiture



A130R / 1294P cat. LH - Champagne Gold

p. 34-35

Chair with embroidered back.
Wooden structure covered in leather 1294P cat. LH. Metal legs in Champagne Gold finish.

Sedia con schienale ricamato.
Struttura in legno rivestita in pelle 1294P cat. LH. Gambe in metallo finitura Champagne Gold.



A130 / 770/A cat. T - Champagne Gold

p. 38

Chair.
Wooden structure covered in fabric 770/A cat. T. Metal legs in Champagne Gold finish.

Sedia.
Struttura in legno rivestita in tessuto 770/A cat. T. Gambe in metallo finitura Champagne Gold.



A130 / 1291P cat. LH - Champagne Gold

p. 43 / 49

Chair.
Wooden structure covered in leather 1291P cat. LH. Metal legs in Champagne Gold finish.

Sedia.
Struttura in legno rivestita in pelle 1291P cat. LH. Gambe in metallo finitura Champagne Gold.



A130 / 765/A cat. T - Graphite Grey

p. 50-51

Chair.
Wooden structure covered in fabric 765/A cat. T. Metal legs in Graphite Grey finish.

Sedia.
Struttura in legno rivestita in tessuto 765/A cat. T. Gambe in metallo finitura Graphite Grey.

Structure: metal and curved plywood / **Seat cushion and backrest:** Polyurethane foam in different densities / **Pre-upholstery:** polyester wadding / **Upholstery:** non-removable in fabric or leather. Available with embroidery or plain back / **Legs:** metal in Champagne Gold or Graphite Grey finish.

Struttura: metallo e multistrato curvato / **Cuscino seduta e schienale:** Poliuretano espanso a quote differenziate / **Prerivestimento:** ovatta di poliestere / **Rivestimento:** non removibile in tessuto o pelle. Schienale disponibile con o senza ricamo / **Gambe:** metallo finitura Champagne Gold o Graphite Grey.

A174

Small armchair with plain back

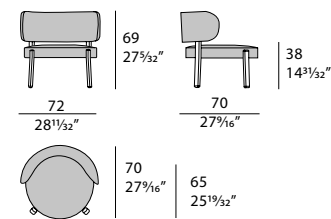

A174R

Small armchair with embroidered back

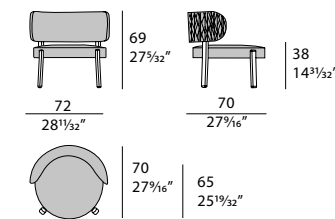

Finishes of photographed items / Riferimenti fotografici finiture



A174 / 1295P cat. LH - Champagne Gold

p. 10

Small armchair.
Wooden structure covered in leather 1295P cat. LH. Metal legs in Champagne Gold finish.

Poltroncina.
Struttura in legno rivestita in pelle 1295P cat. LH. Gambe in metallo finitura Champagne Gold.



A174 / 765/A cat. T - Champagne Gold

p. 45 / 55 / 58

Small armchair.
Wooden structure covered in fabric 765/A cat. T. Metal legs in Champagne Gold finish.

Poltroncina.
Struttura in legno rivestita in tessuto 765/A cat. T. Gambe in metallo finitura Champagne Gold.

Structure: metal in Champagne Gold or Graphite Grey finish. / **Lamp:** metal in Champagne Gold finish with LED.

Struttura: metallo finitura Champagne Gold o Graphite Grey / **Lampada:** metallo finitura Champagne Gold con LED.

A190

Side table with LED lamp

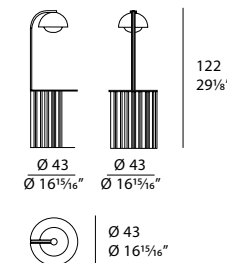

A180

Side table

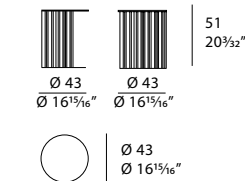

Finishes of photographed items / Riferimenti fotografici finiture



A190 / Champagne Gold

p. 42 / 55 / 58-59 / 60 / 65

Side table with LED lamp.
Metal structure in Champagne Gold finish.

Tavolino laterale con lampada LED.
Struttura in metallo finitura Champagne Gold.



A180 / Champagne Gold

p. 45 / 59

Side table.
Metal structure in Champagne Gold finish.

Tavolino laterale.
Struttura in metallo finitura Champagne Gold.

Structure: MDF, plywood, glossy monochrome lacquered polyester finish. Leather application / **Top:** available with leather application or marble / **Doors:** three doors available in three options: with wooden doors, with printed wooden doors or with glass doors / **Internal equipment:** one compartment with one glass shelf. **A100V-A100MV** no shelf / **Details and feet:** metal in Champagne Gold or Graphite Grey finish.

Struttura: MDF, multistrato finitura laccato monocolor poliestere lucido. Applicazioni in pelle / **Top:** disponibile con applicazioni in pelle o marmo / **Ante:** tre ante disponibili in tre varianti: con ante in legno, con ante in legno stampato, con ante in vetro / **Dotazione interna:** un vano con un ripiano in vetro. **A100V-A100MV** nessun ripiano / **Dettagli e piedini:** metallo finitura Champagne Gold o Graphite Grey.

A100L

Wooden doors and leather top

A100M

Wooden doors and marble top

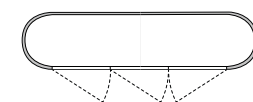
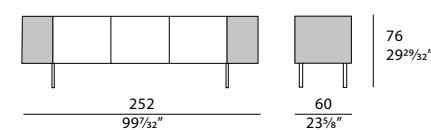
**A100LS**

Wooden doors with pattern and leather top

A100MS

Wooden doors with pattern and marble top

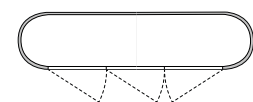
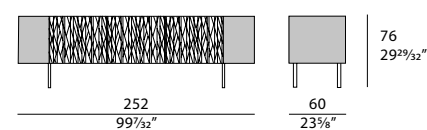
**A100V**

Glass doors and leather top

A100MV

Glass doors and marble top

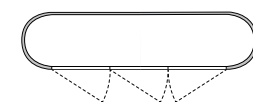
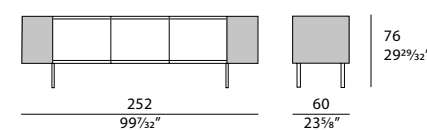

Finishes of photographed items / Riferimenti fotografici finiture

**A100MS** / LLBN01 - 1294P cat. LH - 206M cat 02 - Champagne Gold

Sideboard, wooden doors with pattern and marble top.
Wooden structure glass polyester finish pinkish white colour laquered LLBN01. Leather application 1294P cat. LH. Top in marble Calacatta Oro 206M cat. 02. Metal feet and detail in Champagne Gold.

Credenza, ante in legno con stampa e top in marmo.
Struttura in legno laccato poliestere lucido finitura color bianco rosato LLBN01. Applicazioni in pelle 1294P cat. LH. Top in marmo Calacatta Oro 206M cat. 02. Piedini e dettagli in metallo finitura Champagne Gold.

p. 19 / 20-21 / 22-23

Structure: MDF and plywood, glossy monochrome lacquered polyester finish. Leather application. Top in leather / **Doors:** two doors available in three options: with wooden doors, with printed wooden doors or with one glass door / **Internal equipment:** one compartment with four glass shelves / **Details and feet:** metal in Champagne Gold or Graphite Grey finish.

Struttura: MDF e multistrato finitura laccato monocolor poliestere lucido. Applicazioni in pelle. Top in pelle. / **Ante:** due ante disponibili in tre varianti: con ante in legno, con ante in legno stampato, con ante in vetro / **Dotazione interna:** un vano con quattro ripiani in vetro / **Dettagli e piedini:** metallo finitura Champagne Gold o Graphite Grey.

A111L

Cabinet with wooden doors

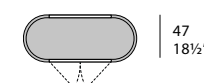
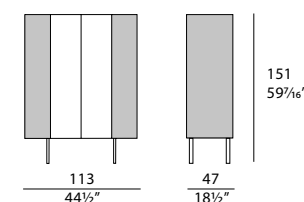
**A111LS**

Cabinet with wooden doors with pattern

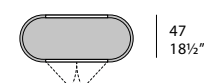
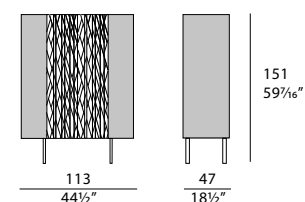
**A111LV**

Vitrine

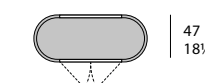
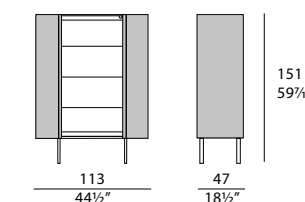

Finishes of photographed items / Riferimenti fotografici finiture

**A111LS** / LLBN01 - 1294P cat. LH - Champagne Gold

Cabinet with wooden door with pattern.
Wooden structure glass polyester finish pinkish white colour laquered LLBN01. Leather application 1294P cat. LH. Metal feet and detail in Champagne Gold.

Mobile contenitore con ante in legno con stampa.
Struttura in legno laccato poliestere lucido finitura color bianco rosato LLBN01. Applicazioni in pelle 1294P cat. LH. Piedini e dettagli in metallo finitura Champagne Gold.

p. 11 / 13 / 25 / 26-27

**A111LV** / LLBN01 - 1294P cat. LH - Champagne Gold

Vitrine.
Wooden structure glass polyester finish pinkish white colour laquered LLBN01. Leather application 1294P cat. LH. Metal feet and detail in Champagne Gold. Additionally set of led-lights for LED 15.

Vetrina.
Struttura in legno laccato poliestere lucido finitura color bianco rosato LLBN01. Applicazioni in pelle 1294P cat. LH. Piedini e dettagli in metallo finitura Champagne Gold. Set illuminazione led addizionale LED 15.

p. 27 / 28-29 / 33

Structure: MDF glossy monochrome lacquered polyester finish. Back panel with embroidery leather application / **Shelves:** available with two or three shelves / **Details:** metal in Champagne Gold or Graphite Grey finish.

Struttura: MDF finitura laccato monocolor poliestere lucido. Schienale con applicazioni in pelle ricamata / **Ripiani:** disponibile con due o tre ripiani / **Dettagli:** metallo finitura Champagne Gold o Graphite Grey.

A160R

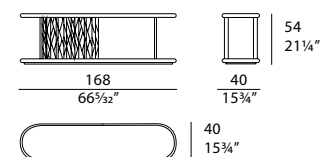

A161R

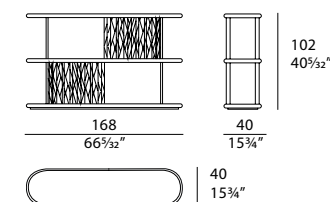

Finishes of photographed items / Riferimenti fotografici finiture



A161R / LLVE01 - 1295P cat. LH - Champagne Gold

p. 10 / 46

Etagere.

Wooden structure gloss polyester finish green colour laquered LLVE01. Leather application with embroidery 1295P cat. LH. Metal details in Champagne Gold.

Etagere.

Struttura in legno laccato poliestere lucido finitura color verde LLVE01. Applicazioni in pelle con ricamo 1295P cat. LH. Piedini e dettagli in metallo finitura Champagne Gold.



A161R / LLBN01 - 1294P cat. LH - Champagne Gold

p. 47

Etagere.

Wooden structure gloss polyester finish pinkish white colour laquered LLBN01. Leather application with embroidery 1294P cat. LH. Metal details in Champagne Gold.

Etagere.

Struttura in legno laccato poliestere lucido finitura color bianco rosato LLBN01. Applicazioni in pelle con ricamo 1294P cat. LH. Piedini e dettagli in metallo finitura Champagne Gold.



A161R / LLBL01 - 1291P cat. LH - Champagne Gold

p. 42 / 45

Etagere.

Wooden structure gloss polyester finish blue colour laquered LLBL01. Leather application with embroidery 1291P cat. LH. Metal details in Champagne Gold.

Etagere.

Struttura in legno laccato poliestere lucido finitura color blu LLBL01. Applicazioni in pelle con ricamo 1291P cat. LH. Dettagli in metallo finitura Champagne Gold.



A160R / LLBN01 - 1294P cat. LH - Champagne Gold

p. 46

Etagere.

Wooden structure gloss polyester finish pinkish white colour laquered LLBN01. Leather application with embroidery 1294P cat. LH. Metal details in Champagne Gold.

Etagere.

Struttura in legno laccato poliestere lucido finitura color bianco rosato LLBN01. Applicazioni in pelle con ricamo 1294P cat. LH. Piedini e dettagli in metallo finitura Champagne Gold.

Structure: solid wood and plywood. Available in center room version with the additional panel on the back / **Padding:** Polyurethane foam in different densities / **Pre-upholstery:** polyester wadding / **Upholstery:** non-removable in leather or fabric. Available with plain or embroidered side panels. It should be noted that in the version with leather upholstery there will be seams, as the leathers cannot reach the size necessary to cover in a single piece.

Struttura: legno massello e multistrato. Disponibile nella versione centro stanza con l'aggiunta di un pannello sul retro / **Imbottitura:** Poliuretano espanso a quote differenziate / **Prerivestimento:** ovatta di poliestere / **Rivestimento:** non removibile in pelle o tessuto. Disponibile con pannelli laterali lisci o ricamati. Si fa notare che nella versione con rivestimento in pelle saranno presenti delle cuciture, in quanto le pelli non possono raggiungere le dimensioni necessarie per rivestire in un unico pezzo.

A140K

Bed with plain side panels.

A140KR

Bed with embroidered side panels.

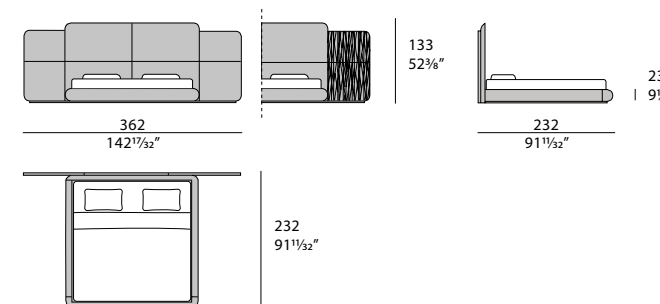

A140

Bed with plain side panels.

A140R

Bed with embroidered side panels.

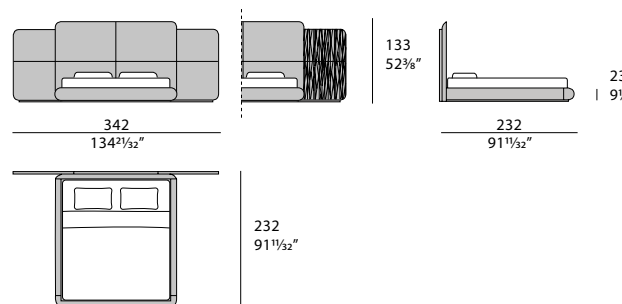

Finishes of photographed items / Riferimenti fotografici finiture



A140KR+A138K / 1294P cat. LH - 770/A cat. T

p. 60-61 / 65

King size bed with embroidered side panels. Additional plain panel for headboard back.

Side panels with embroidery covered in leather 1294P cat. LH. Central panel and bed frame covered in fabric 770/A cat. T. Bedspread and loose decorative cushions available on request in different size and covers.

Letto king size con pannelli laterali ricamati. Pannello aggiuntivo liscio retro testata.

Pannelli laterali ricamati rivestiti in pelle 1294P cat. LH. Pannello centrale e giroletto rivestiti in tessuto 770/A cat. T. Copriletto e cuscini decorativi disponibili su richiesta in diverse dimensioni e rivestimenti.



A140KR / 765/A cat. T

p. 62-63 / 66-67

King size bed with plain side panels.

All covered in fabric 765/A cat. T. Bedspread and loose decorative cushions available on request in different size and covers.

Letto king size con pannelli laterali lisci.

Rivestito interamente in tessuto 765/A cat. T. Copriletto e cuscini decorativi disponibili su richiesta in diverse dimensioni e rivestimenti.

Structure: MDF and plywood, glossy monochrome lacquered polyester finish. Leather application / **Equipment:** available with four drawers or with three drawers and one shelf / **Details:** A141L metal in Champagne Gold or Graphite Grey finish.

Struttura: MDF e multistrato, finitura laccato monocoloro poliestere lucido. Applicazioni in pelle / **Dotazione:** disponibile con quattro cassetti o con tre cassetti e un ripiano / **Dettagli:** A141L metallo finitura Champagne Gold o Graphite Grey.

A146L

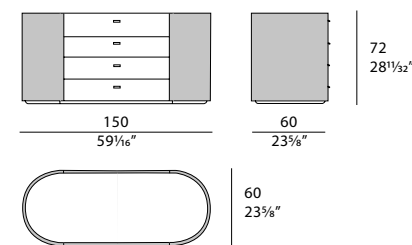

A141L

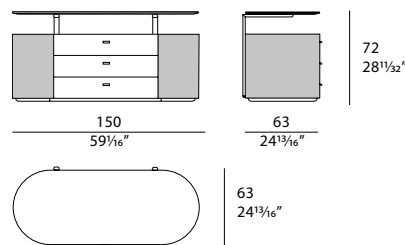

Finishes of photographed items / Riferimenti fotografici finiture



A141L / LLBN01 - 1294P cat. LH - Champagne Gold

p. 60-61 / 69

Chest of drawers.
Wooden structure glass polyester finish pinkish white colour laquered LLBN01. Leather application 1294P cat. LH. Metal details in Champagne Gold finish.

Comò.
Struttura in legno laccato poliestere lucido finitura color bianco rosato LLBN01. Applicazioni in pelle 1294P cat. LH. Dettagli in metallo finitura Champagne Gold.



A146L / LLBN01 - 1294P cat. LH

p. 71

Chest of drawers.
Wooden structure glass polyester finish pinkish white colour laquered LLBN01. Leather application 1294P cat. LH.

Comò.
Struttura in legno laccato poliestere lucido finitura color bianco rosato LLBN01. Applicazioni in pelle 1294P cat. LH.



A141L / LLVE01 - 1295P cat. LH - Champagne Gold

p. 70

Chest of drawers.
Wooden structure glass polyester finish green colour laquered LLVE01. Leather application 1295P cat. LH. Metal details in Champagne Gold finish.

Comò.
Struttura in legno laccato poliestere lucido finitura color verde LLVE01. Applicazioni in pelle 1295P cat. LH. Dettagli in metallo finitura Champagne Gold.

Structure: MDF and plywood, glossy monochrome lacquered polyester finish. Leather application / **Equipment:** one drawer and one shelf / **Details:** metal in Champagne Gold or Graphite Grey finish.

Struttura: MDF e multistrato, finitura laccato monocoloro poliestere lucido. Applicazioni in pelle / **Dotazione:** un cassetto e un ripiano / **Dettagli e piedini:** metallo finitura Champagne Gold o Graphite Grey.

A142L

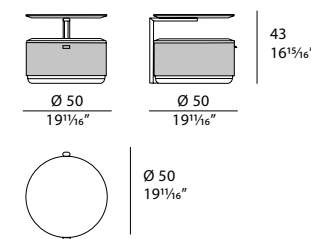

Finishes of photographed items / Riferimenti fotografici finiture



A142L / LLBN01 - 1294P cat. LH - Champagne Gold

p. 72-73

Bedside table.
Wooden structure glass polyester finish pinkish white colour laquered LLBN01. Leather application 1294P cat. LH. Metal details in Champagne Gold.

Comodino.
Struttura in legno laccato poliestere lucido finitura color bianco rosato LLBN01. Applicazioni in pelle 1294P cat. LH. Dettagli in metallo finitura Champagne Gold.

Structure: MDF and particle board panels, glossy polyester monochrome lacquered finish / **Mirror:** **Struttura:** MDF e pannelli di particelle di legno finitura laccato monocoloro poliestere lucido / **Specchio:** finitura bronzo.

A150

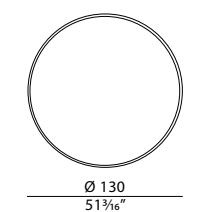

Finishes of photographed items / Riferimenti fotografici finiture



A150 / LLBN01

p. 19 / 42 / 55 / 56-57 / 60-61 / 69

Mirror.
Wooden structure glass polyester finish pinkish white colour laquered LLBN01.

Specchio.
Struttura in legno laccato poliestere lucido finitura color bianco rosato LLBN01.

Structure: MDF and plywood glossy monochrome lacquered polyester finish. Leather application / **Equipment:** four drawers. **A143L** with mirror / **Details and legs:** metal in Champagne Gold or Graphite Grey finish.

Struttura: MDF e multistrato finitura laccato monocolore poliestere lucido. Applicazioni in pelle / **Dotazione:** quattro cassetti. **A143L** con specchio. / **Dettagli e gambe:** metallo finitura Champagne Gold o Graphite Grey.

A143L

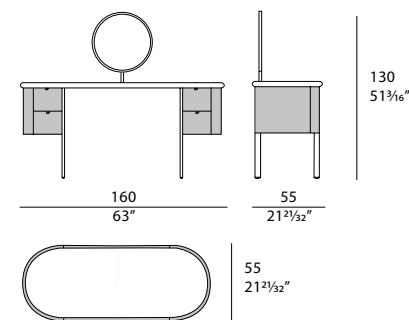

A145L

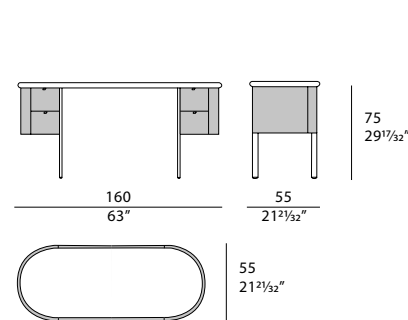

Finishes of photographed items / Riferimenti fotografici finiture



A145L / LLBN01 - 1294P cat. LH - Champagne Gold

p. 37 / 38-39 / 61

Beauty without mirror.
Wooden structure glass polyester finish pinkish white colour lacquered LLBN01. Leather application 1294P cat. LH. Metal details in Champagne Gold finish.

Beauty senza specchio.
Struttura in legno laccato poliestere lucido finitura color bianco rosato LLBN01. Applicazioni in pelle 1294P cat. LH. Dettagli in metallo finitura Champagne Gold.



A143L / LLBN01 - 1294P cat. LH - Champagne Gold

p. 75

Beauty with mirror.
Wooden structure glass polyester finish pinkish white colour lacquered LLBN01. Leather application 1294P cat. LH. Metal details in Champagne Gold finish.

Beauty con specchio.
Struttura in legno laccato poliestere lucido finitura color bianco rosato LLBN01. Applicazioni in pelle 1294P cat. LH. Dettagli in metallo finitura Champagne Gold.



A143L / LLVE01 - 1295P cat. LH - Champagne Gold

p. 76-77

Beauty with mirror.
Wooden structure glass polyester finish green colour lacquered LLVE01. Leather application 1295P cat. LH. Metal details in Champagne Gold finish.

Beauty con specchio.
Struttura in legno laccato poliestere lucido finitura color verde LLVE01. Applicazioni in pelle 1295P cat. LH. Dettagli in metallo finitura Champagne Gold.

Structure: MDF and plywood. / **Cushions:** in Poliurethane in different densities and polyester wadding / **Upholstery:** non-removable in leather or fabric. Available with or without embroidery

Struttura: MDF e multistrato. / **Imbottitura:** in Poliuretano espanso a quote differenziate e ovatta di poliestere / **Rivestimento:** non removibile in pelle o tessuto. Disponibile con o senza ricamo

A136R

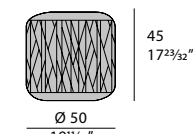

A136

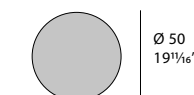
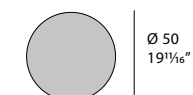
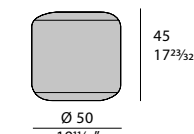

Finishes of photographed items / Riferimenti fotografici finiture



A136R / 1294P cat. LH

p. 75 / 78-79

Pouf with embroidery.
Wooden structure covered in embroidered leather 1294P cat. LH.

Pouf con ricamo.
Struttura in legno rivestita in pelle con ricamo 1294P cat. LH.



A136R / 1295P cat. LH

p. 77

Pouf with embroidery.
Wooden structure covered in embroidered leather 1295P cat. LH.

Pouf con ricamo.
Struttura in legno rivestita in pelle con ricamo 1295P cat. LH.

Composition: 100% botanical silk.

Composizione: 100% seta botanica.

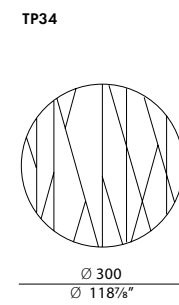
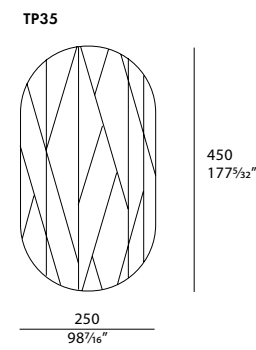

Finishes of photographed items / Riferimenti fotografici finiture



TP35 /

Carpet, 100% botanical silk.

p. 10-11 / 13 / 42-43 / 49 / 82

Tappeto, 100% seta botanica.



TP34 /

Carpet, 100% botanical silk.

p. 28-29 / 32-33 / 37 / 55 / 58 / 83

Tappeto, 100% seta botanica.

TO472
Verde Alpi marble
TO478
Calacatta marble

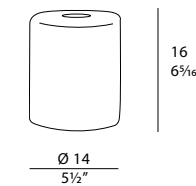

TO473
Verde Alpi marble
TO479
Calacatta marble

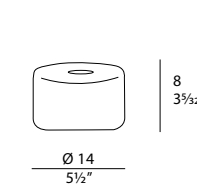

TO474
Verde Alpi marble
TO480
Calacatta marble

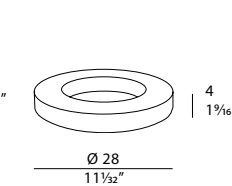

TO477
Verde Alpi marble
TO483
Calacatta marble

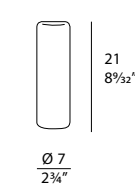

TO475
Verde Alpi marble
TO481
Calacatta marble

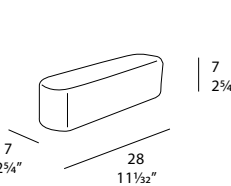

TO476
Verde Alpi marble
TO482
Calacatta marble

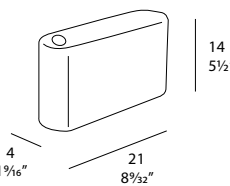

Finishes of photographed items / Riferimenti fotografici finiture



TO478 / Calacatta marble

Big vase in Calacatta marble.
Vaso alto marmo Calacatta.



TO483 / Calacatta marble

Cylinder in Calacatta marble.
Cilindro in marmo Calacatta.



TO472 / Verde Alpi

Big vase in Verde Alpi marble.
Vaso alto marmo Verde Alpi.



TO477 / Verde Alpi

Cylinder in Verde Alpi marble.
Cilindro in marmo Verde Alpi.



TO479 / Calacatta marble

Small vase in Calacatta marble.
Vaso basso in marmo Calacatta.



TO481 / Calacatta marble

Ellipse in Calacatta marble.
Ellisse in marmo Calacatta.



TO473 / Verde Alpi

Small vase in Verde Alpi marble.
Vaso basso in marmo Verde Alpi.



TO475 / Verde Alpi

Ellipse in Verde Alpi marble.
Ellisse in marmo Verde Alpi.



TO480 / Calacatta marble

Circle in Calacatta marble.
Cerchio in marmo Calacatta.



TO482 / Calacatta marble

Ellipse vase in Calacatta marble.
Vaso ellisse in marmo Calacatta.



TO474 / Verde Alpi

Circle in Verde Alpi marble.
Cerchio in marmo Verde Alpi.



TO476 / Verde Alpi

Ellipse vase in Verde Alpi marble.
Vaso ellisse in marmo Verde Alpi.

Monocolour finishings on polyester background. Glossy finish

Finiture monocolori su fondo poliestere finitura lucida.



LLBN01
Glossy pinkish white lacquer
Laccato bianco rosato lucido



LLBN02
Glossy white lacquer
Laccato bianco lucido



LLGR02
Glossy light grey 2 lacquer
Laccato grigio chiaro 2 lucido



LLGR03
Glossy dark grey lacquer
Laccato grigio scuro lucido

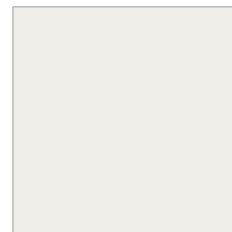

LLGR04
Glossy warm grey lacquer
Laccato grigio caldo lucido

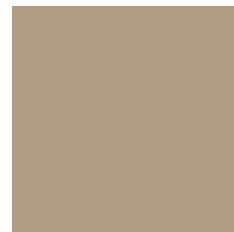

LLTO01
Glossy dove colour lacquer
Laccato tortora lucido



LLSA01
Glossy sand colour lacquer
Laccato sabbia lucido

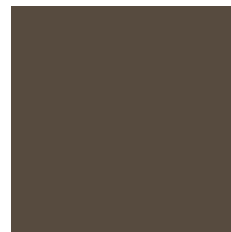

LLMA01
Glossy coffee colour lacquer
Laccato caffè lucido



LLMA02
Glossy light brown lacquer
Laccato marrone chiaro lucido



LLMA03
Glossy brown/ochre lacquer
Laccato marrone/ocra lucido

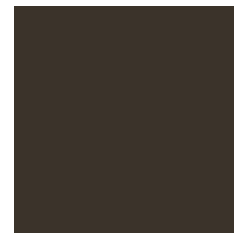

LLMA04
Glossy dark brown lacquer
Laccato marrone scuro lucido



LLBL01
Glossy blue lacquer
Laccato blu lucido



LLNE01
Glossy black lacquer
Laccato nero lucido



LLVE01
Glossy green lacquer
Laccato verde lucido

ROMA COLLECTION - DECORATIVE PATTERN
Decorative pattern for Roma collection available on all
monochrome lacquered polyester finish
Sample of the decorative pattern:



Standard matching of metals color and related furniture collections are mentioned in our catalogues and pricelists. Different matchings are also possible with price increase upon Turri's approval.

Gli abbinamenti standard fra le finiture dei metalli e le collezioni sono menzionate nel nostro catalogo prodotti e listino. Differenti abbinamenti sono possibili con incremento di prezzo, previa approvazione da parte dell'azienda.



CHAMPAGNE GOLD



GRAPHITE GRAY

The samples are purely indicative because the materials are, by nature, subject to variations in color and texture. The round tops in marble Azul Macauba, Port black, Giallo Siena and Nero Portoro more than cm. 140 diam. in.551/8 may be supplied in 4 pieces jointed together.

* Due to the special variegation of this marble it is not possible to match 2 tops from the same order and, moreover, it is not possible to ask of matching tops for replacements or additional orders.

** marble standard produced in matt finish

I campioni sono puramente indicativi in quanto i materiali presentati sono per loro natura soggetti a variazioni di colore e struttura. Per le seguenti tipologie di marmo: Azul Macauba, Port black, Giallo Siena, Nero Portoro, i piani dei tavoli rotondi superiori a Ø140cm - in.551/8 potrebbero essere giuntati in 4 pezzi.

* Dato la particolare variegatura del marmo, su più mobili nello stesso ordine/ambiente non è possibile fare abbinamenti e richiedere abbinamento per integrazioni/sostituzioni.

** marmo che di serie viene presentato in finitura opaca

CAT. 01



100M
ONICE



101M
AZUL MACAUBA



102M
NERO PORTORO



103M *
ONICE FANTASTICO

CAT. 02

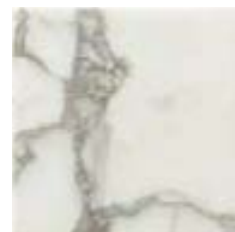

200M
STATUARIO



201M
ROSSO FRANCIA



202M
ROSA PORTOGALLO



203M
GIALLO SIENA



204M
BIANCO SIVEC



205M
TOBACCO AL VERSO



206M
CALACATTA ORO



207M
PORT BLACK



208M**
FANTASY WHITE (matt finishing)



209M**
CORTECCIA (matt finishing)

CAT. 03



300M
BIANCO CALACATTA



301M
EMPERADOR LIGHT

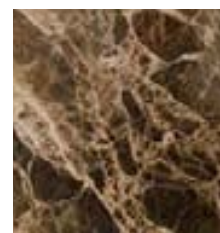

302M
EMPERADOR



303M
NERO MARQUINA



304M
VERDE ALPI GUATEMALA



305M**
GREY STONE (matt finishing)

CAT. 04



400M
BIANCO CARRARA



401M
TRAVERTINO



402M
CREMA MARFIL



403M
BRECCIA SARDA



404M
BARDIGLIO

CAT. 05

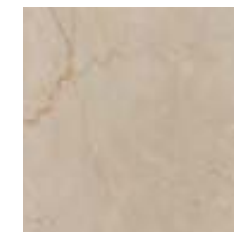

500M
BOTTICINO

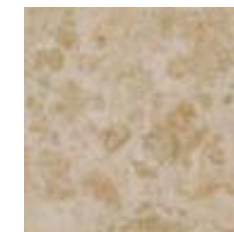

501M
GIALLO ISTRIA

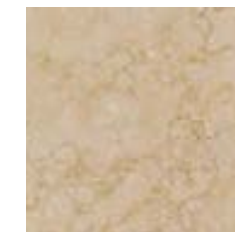

502M
GIALLO SILVA ORO



503M
PIETRA EXTRADURA



504M
ROSA PERLINO

TURRI

Via Ugo Foscolo, 6
22060 Carugo, Como (Italy)

Phone +39 031 760 111

www.turri.it
info@turri.it