



## DREAMED AND MADE IN ITALY

TATO was conceived to do things well. This is what it's dealing with. There's a deep knowledge arising from practice. Doing things well for a company producing lighting design and furnishing items means to express a way to be and a precise attitude. It means to purposely design in an understated way a personal idea of what freedom is, a personal idea of new, of something you don't look for, because you live with it every day.

TATO's idea of design translates into a new economic and cultural scenario and in a future-oriented tradition of manual dexterity, knowledge of gestures, materials and handicrafts. All those elements that make Italy well known in the world. There is no industry that can do well without handicrafts.

The constant manual work on the materials and the forms they can take, the surprise and the intimate familiarity that derive from them, gives us back a range of objects representing characters, talking to us within an architecture, feeling always comfortable and behaving. These objects can keep their value over time. Good design begins with people. TATO surrounds itself with people who are similar but also with very different. Not only architects and designers but a large intellectual group aiming to research and experiment. Particularly significant are the relationships with the local artisans in the area where the company was born, and the international relationship, helping to spread its ideas. Listening to people is crucial. More and more people, sophisticated people, looking for history and culture in the things they choose.

TATO takes culture into particular account and is engaged in many processes. We like to dig out from history those objects that are produced today but belong to our recent, or even not so recent, past.

## IT'S NOT JUST ABOUT GOOD DESIGN

There is a special quality in some design firms, which is considering the aesthetic purpose as their basic foundation, even from an economic point of view. That's because cultural contents are more and more an expression of people's choices.

TATO's proposal is a newly structured and poetic model where the visual research goes together with the industrial experimentation, the philology of materials and techniques, both new and old, the discovery of new production geographies in order to build a catalogue in which the content stimulus and the edition methods are more privileged than the manufacturing limitations and the assembly line repetitiveness.

It's not just about good design: it's about a more complex vision of the world, of things and of living, it's about an attitude that brings together a network of knowledge including the hand-made and machine-made and that is related with the more anthropological aspects of craftsmanship and industry.

Choosing good authors is necessary to transfer the art phenomenology in the object and to make aesthetic and functional information be coincident. It's important to practice an intense professional and affective relationship between client, designer and company that belongs to the culture of the project. So the object becomes a part of a vast and very articulate narrative program that, in pursuing a personal image, redefines the relationship between industrial production and production of knowledge.







# Modern designers



**Corrado Corradi Dell'Acqua**

Corrado Corradi Dell'Acqua (Milan 1905 - Varese 1982) was a law expert, an amateur writer, and quietly became a designer. His dachshund's name was Azucena like the company Corradi had started in 1947 with two other young Milanese intellectuals, Luigi Caccia Dominioni and Ignazio Gardella. Corrado Corradi had fun designing chintz with Luchino Visconti and he liked ceramic. He designed lamps made with glass from Milan's tramcars and many other objects for the house, with a precise idea of living in mind.



**Alberto Rosselli**

Alberto Rosselli (Palermo, 1921 – Milan, 1976) graduated just after the end of the war from the Architecture Faculty of the Politecnico di Milano. From the start of his career and in parallel to his activity as architect, he carried out theoretical studies and worked as a designer in different fields, from product design to furniture, to transport. In 1953, as director, he brought out the magazine "Stile Industria". In 1956 he was Chairman of the Italian Association of Industrial Design (ADI). His intense work as architect was carried out in the Ponti-Fornaroli-Rosselli studio, becoming a co-creator in its projects in the 1950s.

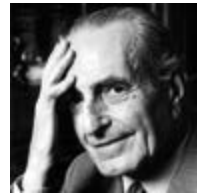

**Ignazio Gardella**

Ignazio Gardella (Milan, 1905 - Oleggio, 1999) was one of the leading figures in Italian 20th century architecture. Even before the war he had performed a series of jobs for the upper classes of Piedmont and Lombardy, clients whom he was able to interpret in many important projects in the period of Reconstruction when he was at the forefront in proposing a new idea of architecture. In 1947, he founded Azucena with Luigi Caccia Dominioni and Corrado Corradi Dell'Acqua. Until the 1990s, Gardella would continue designing furniture and accessories, as well as carrying on his extraordinary activity as architect.



**Eugenio Gerli**

Already experimenting with new materials such as plastic felt and curved plywood before becoming an architect, Eugenio Gerli (Milan, 1923 – 2013) opened his firm in 1949. 1957 marked the start of a long and extraordinary partnership with Osvaldo and Fulgenzio Borsani and Techno, for whom he designed the historic operating system Graphic (1968) and other icons such as the PS142 and S142 seats. In the 1970s, he was joined in the business by his sons, Enrico and Guido, who now also take care of the Archive.



**Gio Ponti**

Gio Ponti is one of the most important figures in 20th century architecture and arts. From 1923 to 1930 he was artistic director of Richard Ginori; in 1928 he founded the magazine "Domus", which would be followed by other great publishing feats such as "Stile". Dating from the late 1920s are the "typical homes", which combined the concept of Italianness with an interest in rationalist theories. Right from the start, he took part in the Triennale design exhibitions in Milan. With Antonio Fornaroli and Alberto Rosselli, in the studio in Via Dezza which would become his home, he conceived an extraordinary series of projects, expressing his "finite form" theory in the fields of furniture with the "organized walls", design and architecture.

# Contemporary designers



**Antonia Astori**

Antonia Astori was born in Melzo (Milan) in 1940. She graduated in Industrial and Visual Design at the Athenaeum of Lausanne in 1966. Since 1968, she has worked as a designer for the Italian company Driade, creating some important system and furniture designs and helping to shape the corporate image with her outfitting and exhibitions. Her activity as a designer goes alongside her work as interior designer, with projects for houses, offices, showrooms and stores.



**Lorenza Bozzoli**

Lorenza Bozzoli was born in Milan, where she studied at the Accademia di Belle Arti di Brera. In 1985 she began working as a fashion designer for Fiorucci, Basile, Plein Sud, Sergio Rossi and Camper among others. In 1996 she became passionately involved in industrial design for Antiquità, Viceversa, Alessi, Dilmos, Dedon and Moooi. She has participated in important exhibitions in Italy and abroad. She lives and works in Milan where she has her own design studio.



**Giulia and Guido Guarnieri**

Giulia and Guido Guarnieri are fond of Milan and 1950s and 60s design. After graduating from the Politecnico di Milano, they became involved in various professional projects regarding design, video art and marketing, both in Italy and in Europe. Giulia is currently a brand manager for an Italian fashion company and Guido is an art director for a design company.



**Hisham Kulhanek**

Hisham Kulhanek was born in Prague in 1958. In 1970 he moved to Amsterdam with his family. After studying at the Delft University of Technology, he decided to move to Milan where he started a long partnership with the Japanese designer Makio Hasuike. Now he runs a multidisciplinary studio focused on product design. He has been a teacher at the Istituto Europeo di Design (IED) in Milan, and has run some workshops at the Domus Academy and at the Politecnico di Milano for the Master's degree in Strategic Design.



**Gianluigi Landoni**

Gianluigi Landoni is an architect and designer. He graduated from the Politecnico di Milano. After many experiences in architecture and industrial design studios, since 1994 he has worked as a freelance alongside numerous design companies. He has participated in various exhibitions and contests for both public and private works, receiving awards and commendations. He has been a teacher at the Istituto Europeo del Design (IED) in Milan.



**Matteo Nunziati**

Matteo Nunziati is considered one of the most influential international architects and designers of his generation. He received numerous important awards for his works in product design; his projects, exclusive and enhanced by the skillful selection of materials and furnishings, usually chosen from the production excellence of Made in Italy design, have been published in the major Italian and international magazines. His solid experience led Nunziati carry out teaching activities at important institutions such as Domus Academy, the National Taipei University of Technology, the IDI Interior Design Institute of Milan and the Tshinghua University Shenzhen in China.



**Alessandro Pasinelli**

Alessandro Pasinelli began by studying fashion and textile design in Milan. In 2004 he opened his own multidisciplinary Design Studio dealing with design, interior, styling and art direction. He collaborates with many companies, editorial offices and photographers. He collects design pieces by great Italian Maestri, loves green projects and the contamination between art, fashion and design, always looking for new communicative languages. He lives and works in Milan, collaborating with a multitasking team able to offer varied creative solutions.



**Studio 2046**

Founded by Daniele Daminelli. "I like the idea of bringing elements of the past into the future." Interior designer by training and founder of Studio2046, Daniele Daminelli imagines and designs contemporary items that combine the strength of industrial processes with the refinement of traditional and artisanal work. In his design practice the attention is especially placed on the details, on the harmony of proportions, on the relationship between materials and on the calibration of the colors.



ALZABILE  
14



ANITA  
20



ARENZANO  
24



BABILA  
42



BEGHINA  
48



BESANA  
54



BIBA  
58



COPPA APERTA  
64



DE-LUX  
72



DOPPIO VETRO  
80



GALLERIA  
86



ICONES  
92



JIL  
98



LEA  
102



LUNA  
110



NETTA  
118



OLLY  
122



ORSOLA  
128



PAGODA APPLIQUE  
132



PAGODA PIANTANA  
136



PAOLINA  
140



PRISMA  
144



SIDEEA  
150



VARESINA  
154



VOX  
160

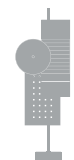

WALLIE  
166



ACCA  
178



ANGOLO  
186



DOMUS  
194



FAGIOLO  
200

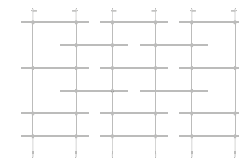

LIBRERIA MODULARE  
204



LIDO  
208



MONFORTE  
214



MONTECARLO  
220



PIEDI REGOLABILI  
224



R63  
230



SELLA  
234



STAND  
238

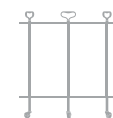

TRE MANIGLIE  
244



TRECENTOSESSENTA  
248



TRUNO  
256



ZOAGLI  
260

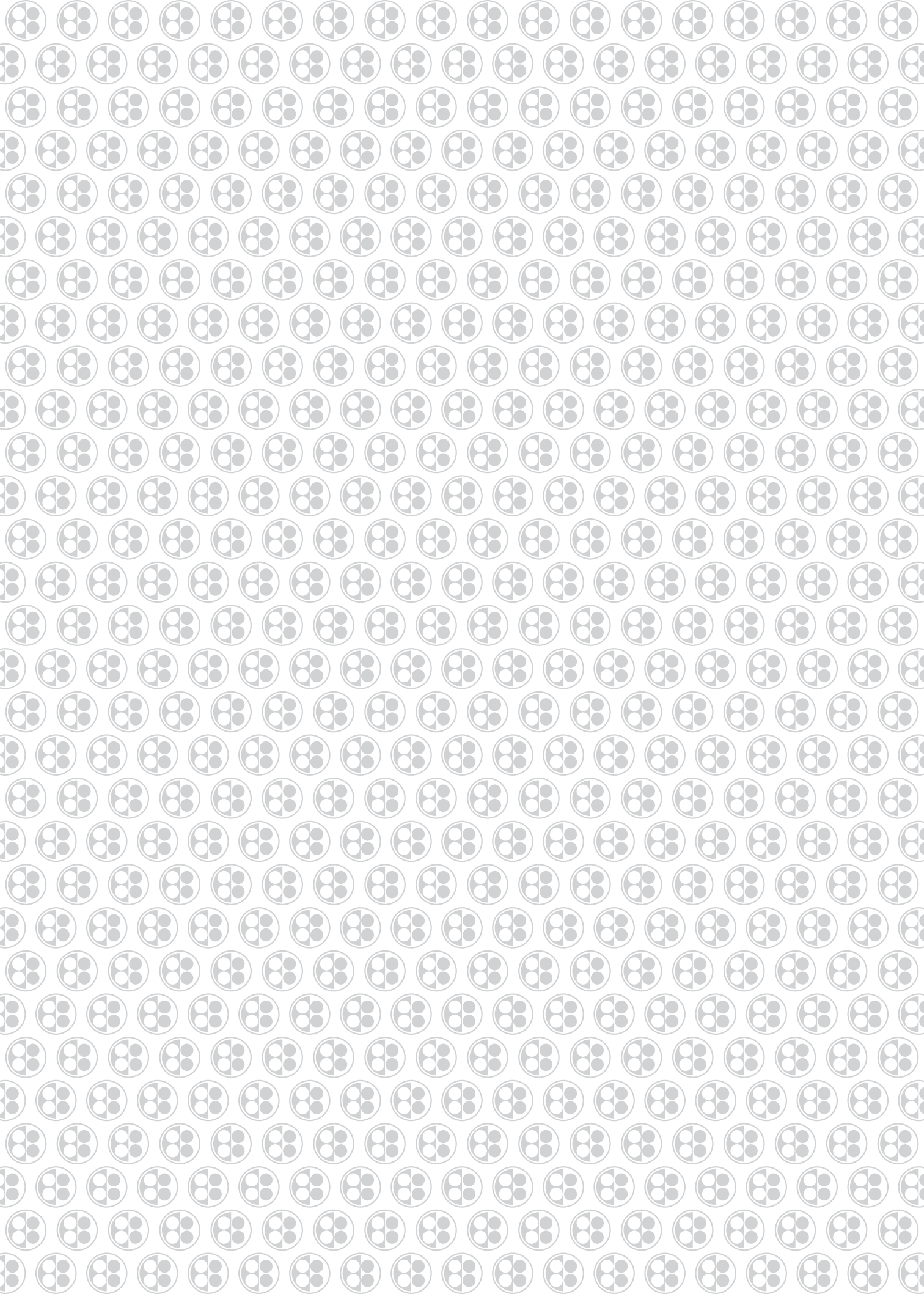

## LIGHTING



# Alzabile

designed by Ignazio Gardella  
1948 / 2017

*Featured in the  
permanent collection of  
New York's **MoMA**.*

## Details

Type: reading lamp  
Materials: marble / brass / aluminum  
Weight: 5,5 kg  
Insulation: class II / IP20  
Bulbs: 1xLED E27/E26 806lm

## Measurements

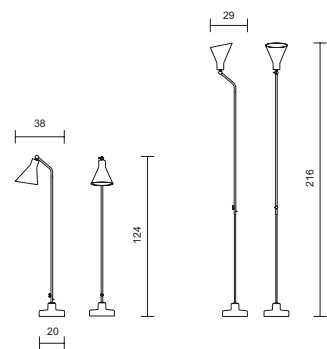

## Finishings

### Body



brass



chrome

### Shade



brass



chrome



glossy white



manganese

### Base



marquinia



carrara



grey









# Anita

designed by Lorenza Bozzoli  
2016

## Details

Type: table lamp  
Materials: marble / brass / glass  
Weight: 7 kg  
Insulation: class II / IP20  
Bulbs: 3xLED E14/E12 470lm

## Measurements

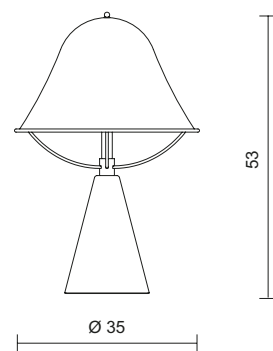

## Finishings

### Glass shade



satin white

### Structure



chrome



satin bronze



satin brass

### Base

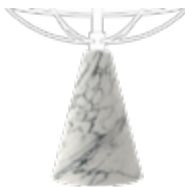

carrara



emperador



# Arenzano

designed by Ignazio Gardella  
1956 / 2018

## Details

Materials: brass / iron / glass  
Insulation: class II / IP20  
Bulbs: 3xLED E14/E12 470lm





## Models



table



table (low)



floor

## Finishings

### Body



brass

chrome

satin nickel

satin bronze

### Glass shade



satin white



glossy green



## Arenzano

Type: table lamp  
Weight: 3,8 Kg

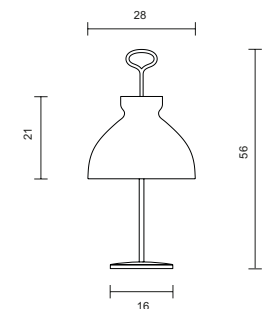



**Arenzano Bassa**

Type: table lamp  
Weight: 2,4 Kg

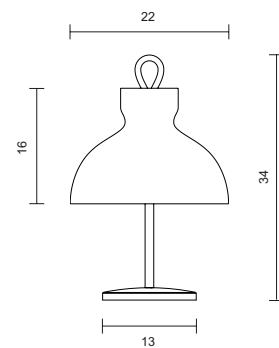

**Arenzano Terra**

Type: floor lamp  
Weight: 5,5 Kg

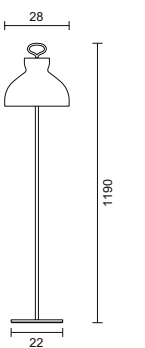





# Arenzano Wireless

based on the design by Ignazio Gardella  
1956 / 2023

*Rechargeable battery powered lamp,  
easily portable.*



USB Type-C

## Details

Type: battery powered table lamp  
Materials: brass / iron / polycarbonate  
Weight: 1,5 Kg  
Insulation: class III / IP20  
Bulbs: dimmable COB, 2700K, max 400lm  
Duration: 8-10 hours at maximum intensity

## Measurements

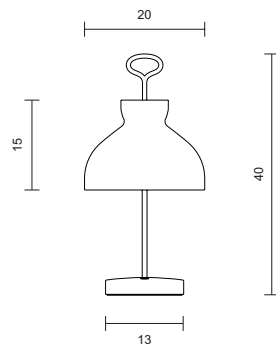



## Finishings

### Body



brass



chrome

---

### Shade



satin white  
translucent

---

### Battery



rechargeable with  
USB-C port  
(cable included)

---



# Arenzano Tre Fiamme

designed by Ignazio Gardella  
1963 / 2019

## Details

Materials: brass / glass / marble  
Insulation: class II / IP20  
Bulbs: 9xLED E14/E12 470lm



## Models

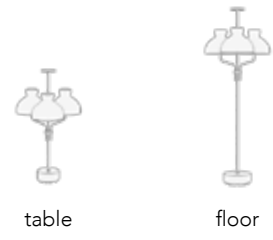

## Finishings

### Body



### Base

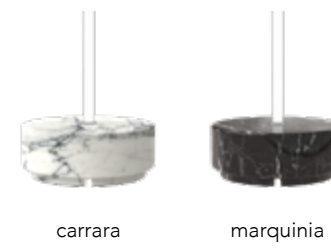

### Glass shade



## Arenzano Tre Fiamme Tavolo

Type: table lamp  
Weight: 15 Kg

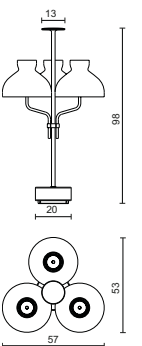





**Arenzano Tre Fiamme Terra**

Type: floor lamp  
Weight: 19 Kg

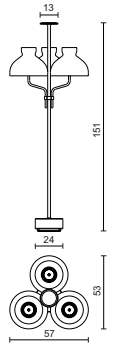

# Babila

designed by Alessandro Pasinelli  
2024

## Details

Materials: aluminum / polycarbonate / iron  
Insulation: class II / IP20  
Bulbs: 3xLED E27/E26 806lm



## Models



table S



table L



floor

## Finishings

### Body



brushed aluminum

### Shade & accents



glossy white  
translucent



glossy black  
opaque



## Babila Tavolo

Type: table lamp  
Weight: 6,5 Kg / 7 Kg

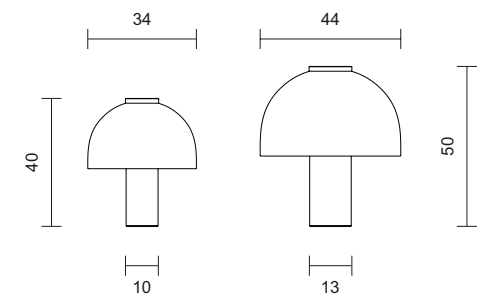





**Babila Terra**

Type: floor lamp  
Weight: 9 Kg

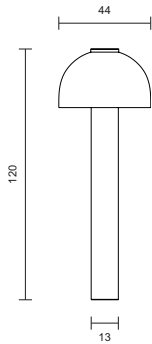

# Beghina

designed by Giulia & Guido Guarnieri  
2011



## Details

Materials: brass / aluminum  
Insulation: class II / IP20  
Bulbs: 1xLED E14/E12 470lm

## Models

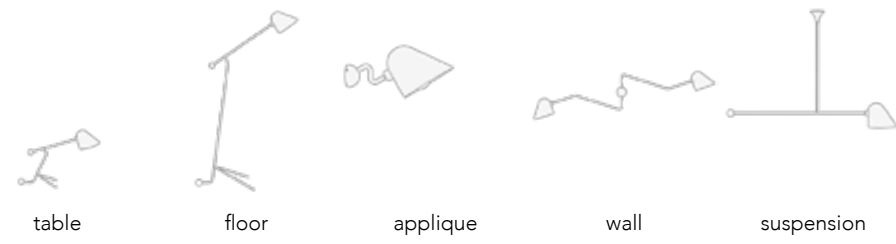

## Finishings

### Body

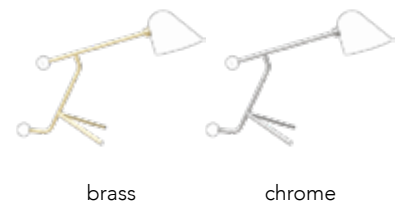

### Shade & accents



## Beghina Tavolo

Type: table lamp  
Weight: 2 Kg

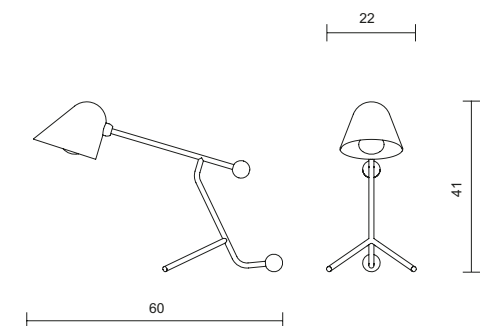





### Beghina Terra

Type: floor lamp  
Weight: 3,5 Kg

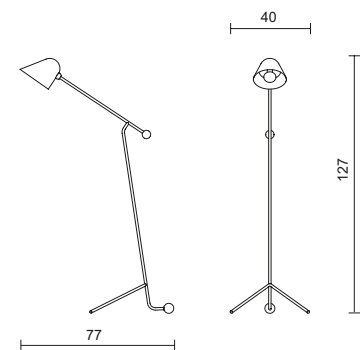

### Beghina Applique

Type: applique lamp  
Weight: 0,8 Kg

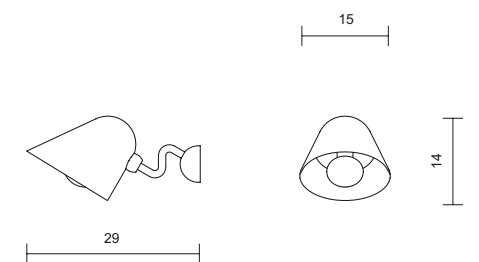

# Besana

designed by Alessandro Pasinelli  
2022

## Details

Type: ceiling lamp  
Materials: polycarbonate / iron / brass  
Weight: 8 kg  
Insulation: class I / IP20  
Bulbs: 6xLED E14/E12 806lm

## Measurements

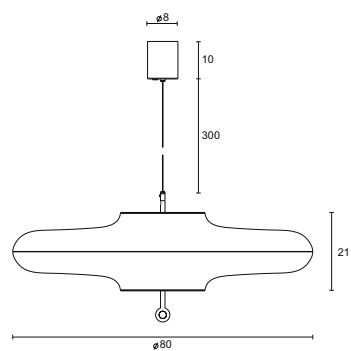

## Models



ceiling

---

## Finishings

### Body



satin white plastic

---

### Accents

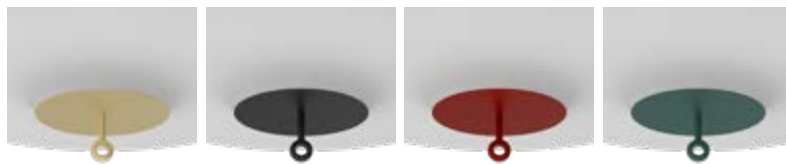

satin brass

matte black

china red

mint green

---



# Biba

designed by Lorenza Bozzoli  
2017

## Details

Materials: brass / iron / glass

Insulation: class II / IP20

Bulbs: 1xLED E27/E26 806lm + 1xLED E14/E12 470lm

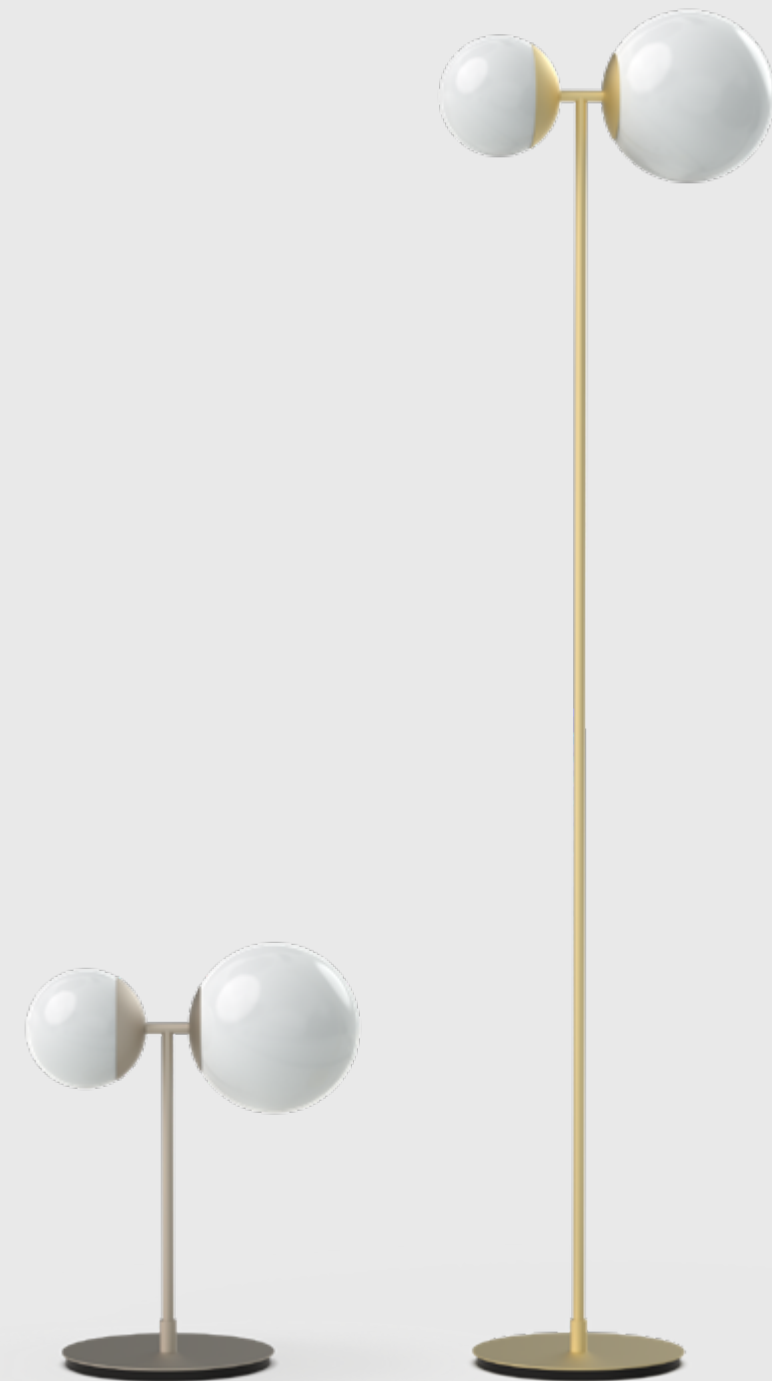



## Models



table



floor



applique



suspension

## Finishings

### Body



satin brass

satin nickel

matte black

### Glass shades



glossy white



## Biba Tavolo

Type: table lamp  
Weight: 6 Kg

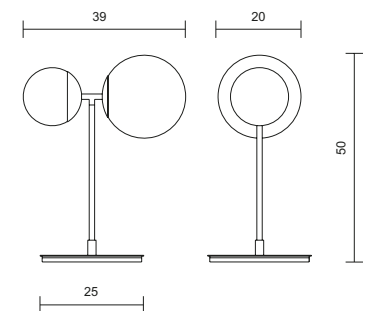



**Biba Applique**

Type: applique lamp  
Weight: 2 Kg

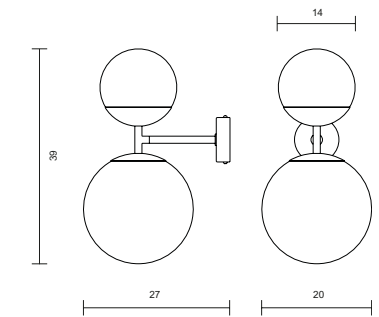

**Biba Sospensione**

Type: ceiling lamp  
Weight: 4,5 Kg

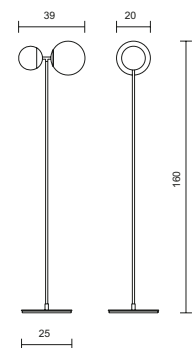
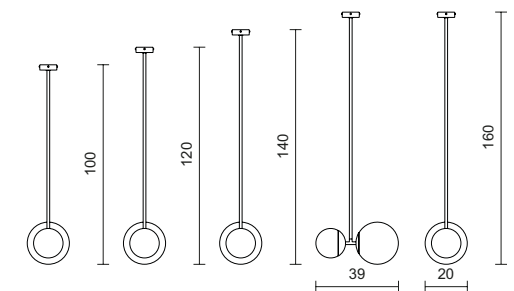

**Biba Terra**

Type: floor lamp  
Weight: 6,5 Kg

# Coppa Aperta

designed by Ignazio Gardella & Corrado Corradi Dell'Acqua  
1954 / 2019



## Details

Materials: brass / aluminum / glass  
Insulation: class II / IP20  
Bulbs: 1xLED E27/E26 806lm



## Models



applique



floor

## Finishings

### Body



brass



chrome



satin nickel



brass



chrome

### Shade holder



glossy black



silver

### Marble base (floor model)



carrara



marquinia



## Coppa Aperta Applique

Type: applique lamp  
Weight: 1,5 Kg

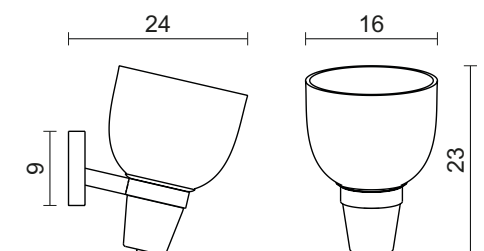







### Coppa Aperta Piantana

Type: floor lamp  
Weight: 6,5 Kg



# De-Lux

designed by Gio Ponti  
1955 / 2017

## Details

Type: floor lamp  
Materials: aluminum / iron / plastic  
Weight: 3,5 ~ 8,5 kg  
Insulation: class II / IP20  
Bulbs: 1xLED E27/E26 2300lm

## Measurements

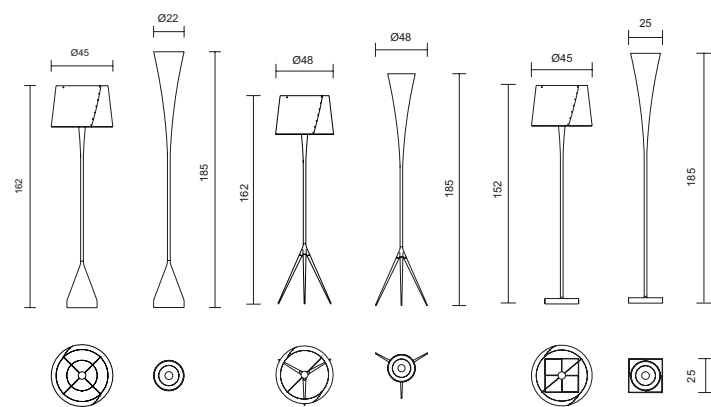

## Finishings

### Shade



plastic shade



cone

### Base shape



"A"



"B"



"D"

### "A" and "B" body color



gold



silver



matte black

### "D" base tiles



white / blue



white / orange

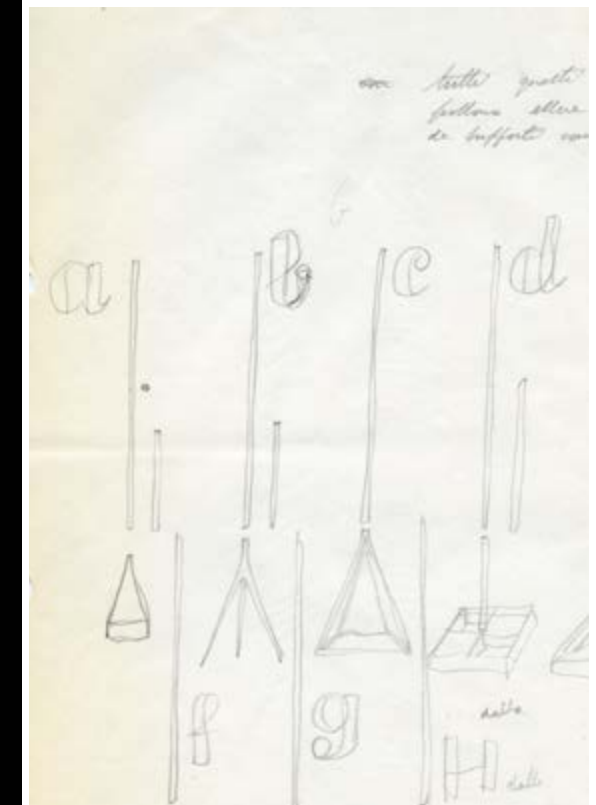
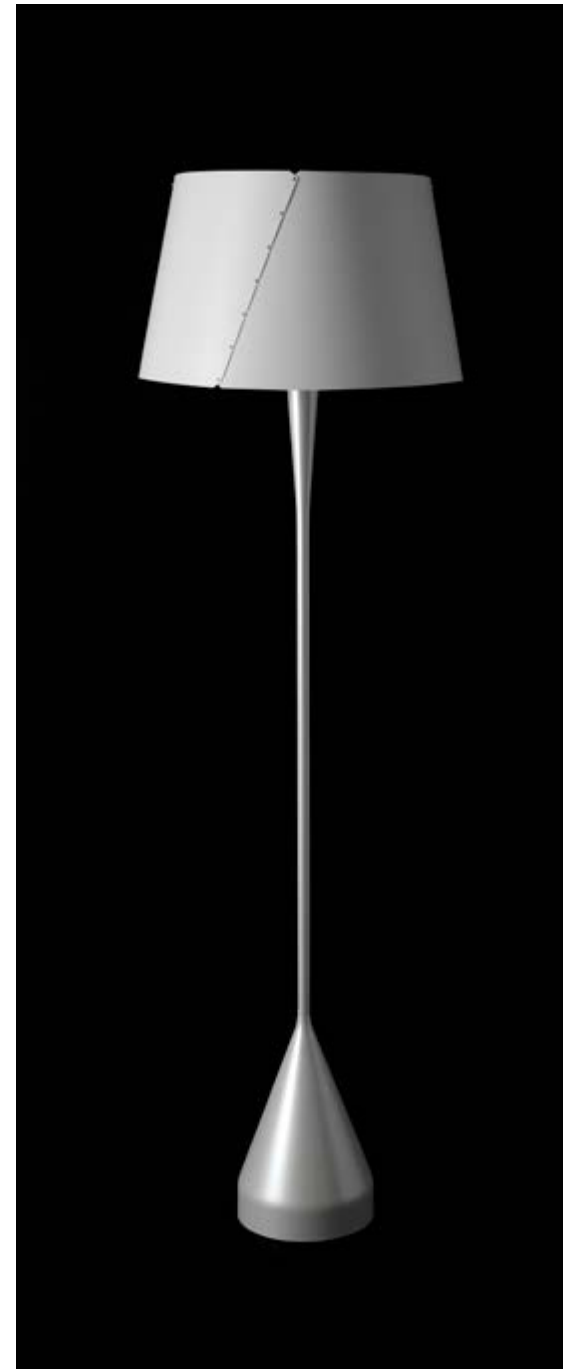









# Doppio Vetro

designed by Ignazio Gardella  
1955 / 2021

## Details

Materials: brass / iron / glass  
Insulation: class I / IP20  
Bulbs: 3xLED E27/E26 806lm



## Models

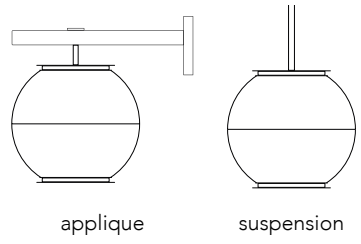

## Finishings

### Body

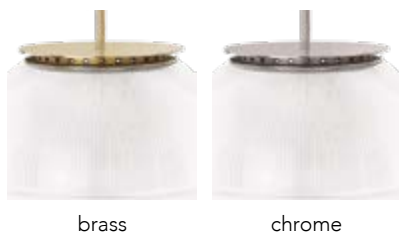

## Doppio Vetro Applique

Type: wall lamp  
Weight: 5,5 Kg

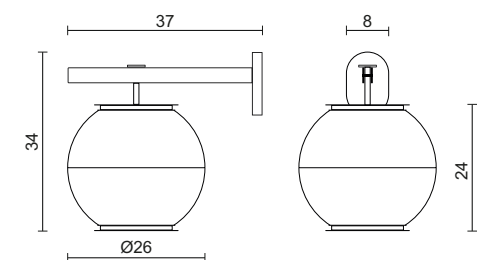





### Doppio Vetro Sospensione

Type: ceiling lamp  
Weight: 5 Kg

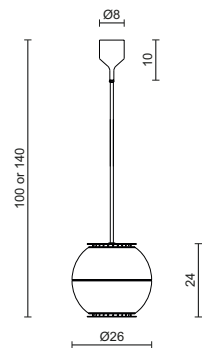

# Galleria

designed by Ignazio Gardella  
1958 / 2019

## Details

Type: wall lamp  
Materials: brass / glass  
Weight: 2 / 3 / 5 / 7 / 8,5 kg  
Insulation: class I / IP20  
Bulbs: 1xLED E27/E26 806lm (each arm)

## Measurements

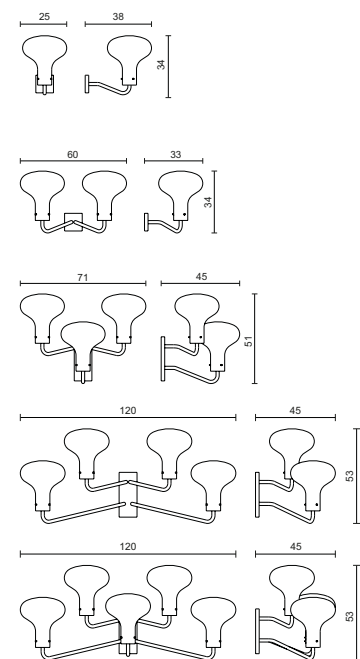

## Finishings

### Models



1 arm



2 arms



3 arms



4 arms



5 arms

### Body

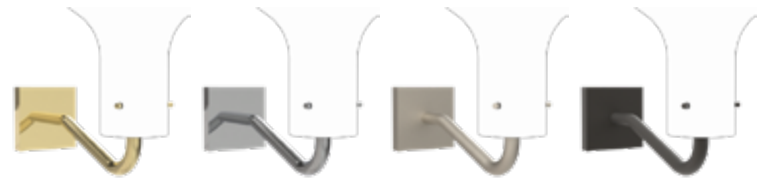

brass

chrome

satin nickel

satin bronze

### Glass shade



satin white



COLLEZIONE GRASSI, GAM MILANO  
© ARCHIVIO STORICO GARDELLA





# Icones

designed by Lorenza Bozzoli  
2019 / 2020

## Details

Materials: aluminum / plastic / brass  
Insulation: class II / IP20  
Bulbs: 3xLED E27/E26 806lm



## Models



table



floor



suspension

## Finishings

### Body



manganese



satin nickel

### Accents



satin brass



satin nickel



## Icones Tavolo

Type: table lamp  
Weight: 8 Kg

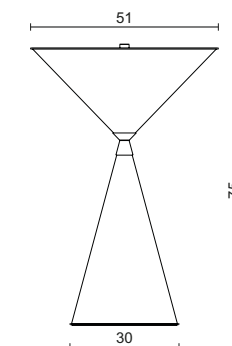



### Icones Piantana

Type: floor lamp  
Weight: 12 Kg

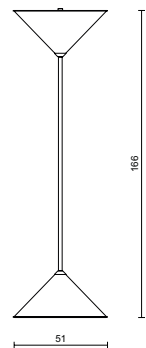

### Icones Sospensione

Type: ceiling lamp  
Weight: 4 Kg

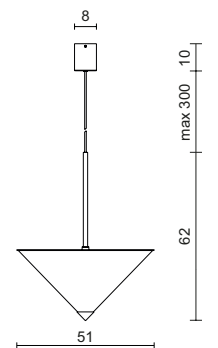



# Jil

designed by Lorenza Bozzoli  
2016

## Details

Type: table lamp  
Materials: marble / brass / glass  
Weight: 7,5 kg  
Insulation: class II / IP20  
Bulbs: 3xLED E14/E12 470lm

## Measurements

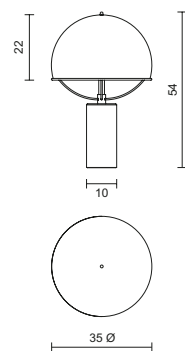

## Finishings

### Metallic structure

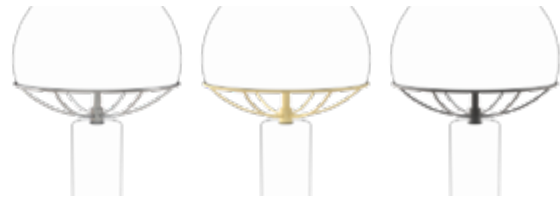

chrome

satin brass

satin bronze

### Marble base



carrara

### Glass shade



glossy white



# Lea

designed by Matteo Nunziati  
2019 / 2020

## Details

Materials: marble / glass or polycarbonate  
Insulation: class II / IP20





## Models

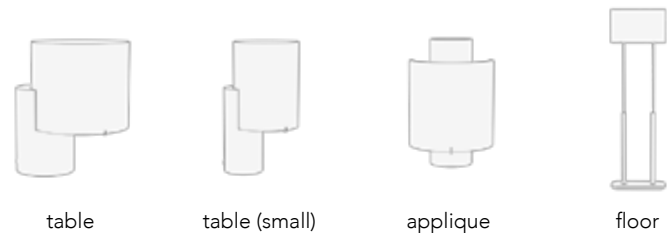

table

table (small)

applique

floor

## Finishings

### Marble base



carrara

marquinia

portoro

### Glass shade



satin white  
(table model)

### Plastic shade



satin white  
(small table model)

satin white  
(applique model)

satin white  
(floor model)



## Lea

Type: table lamp  
 Weight: 11 Kg  
 Bulbs: 1xLED E27/E26 806lm

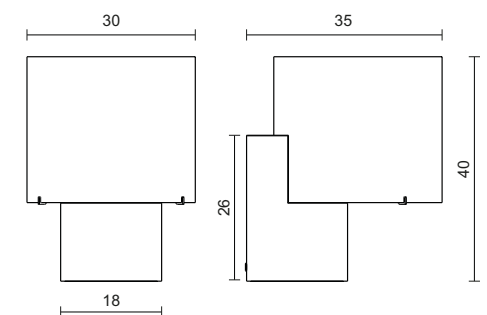



**Leina**

Type: table lamp  
 Weight: 7 Kg  
 Bulbs: 1xLED E14/E12 806lm

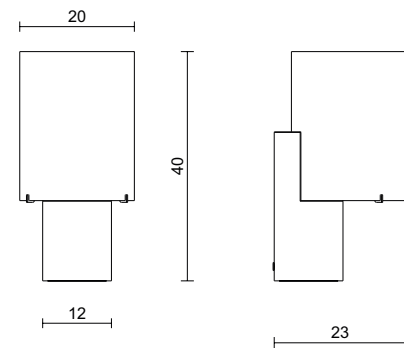

**Lea Applique**

Type: applique lamp  
 Weight: 5 Kg  
 Bulbs: 1xLED E14/E12 806lm

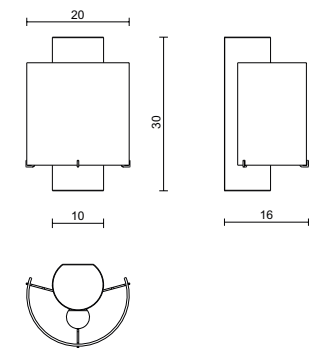



### Lea Piantana

Type: floor lamp  
Weight: 15 Kg  
Bulbs: 2xLED E27/E26 2300lm

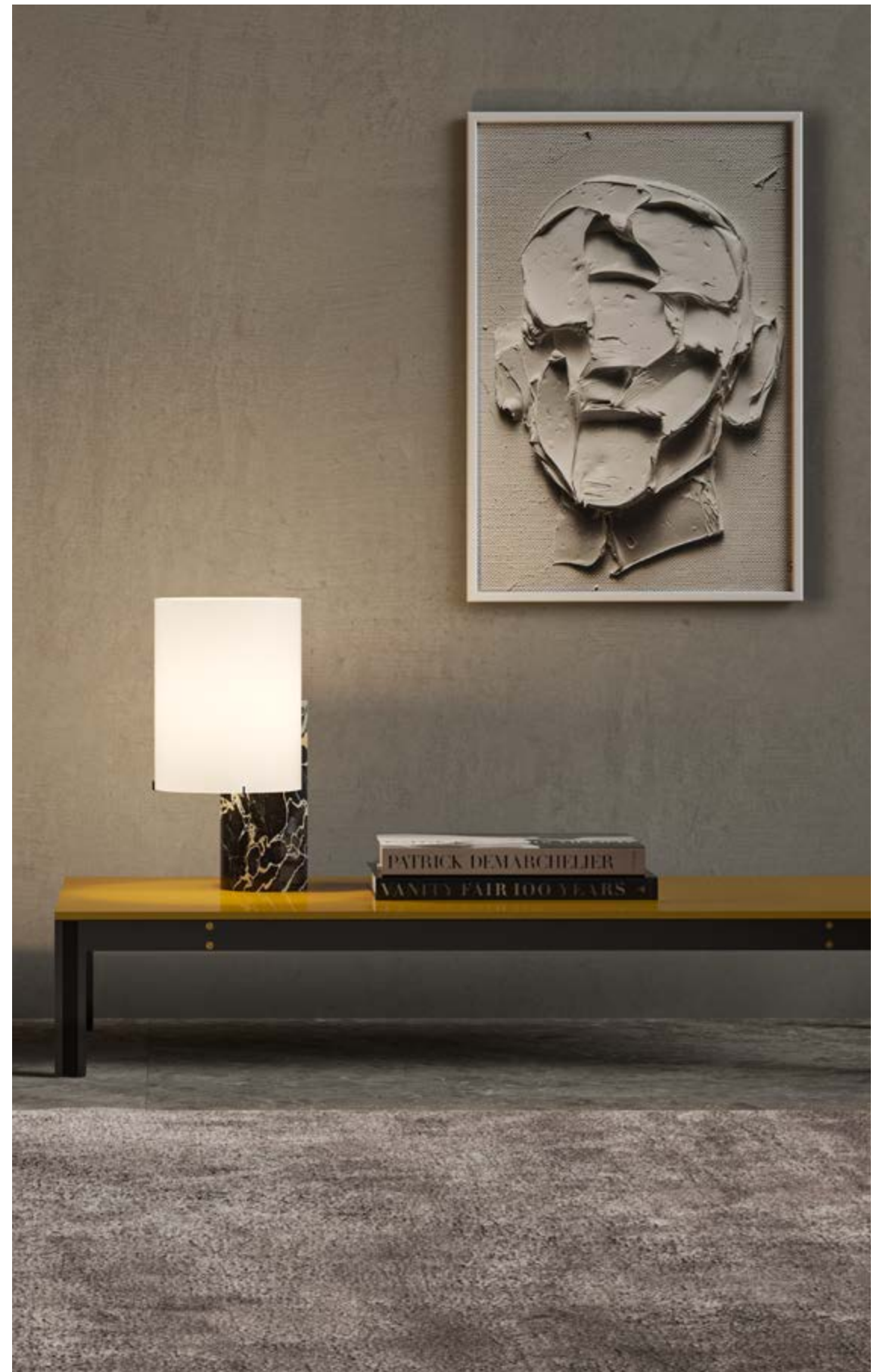
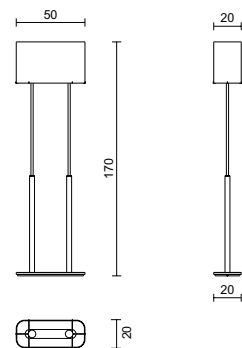

# Luna

designed by Gio Ponti  
1957 / 2018



## Details

Materials: polycarbonate / brass / iron  
Insulation: class II / IP20



## Models



floor horizontal

floor vertical

ceiling

## Finishings

### Body



satin white

glossy white  
and blue

glossy white  
and orange

glossy white  
and grey

### Legs & accents



satin brass

satin nickel

brass



## Luna Orizzontale

Type: floor lamp  
Weight: 3,5 Kg  
Bulbs: 3xLED E27/E26 806lm

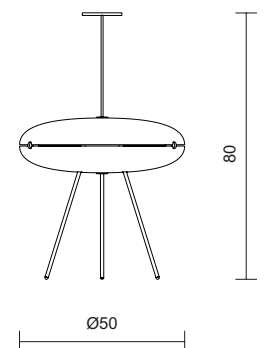



**Luna Sospensione**

Type: ceiling lamp  
Weight: 3 Kg  
Bulbs: 3xLED E27/E26 806lm

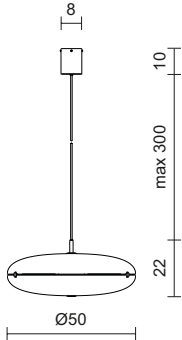



### Luna Verticale

Type: floor lamp  
Weight: 4 Kg  
Bulbs: 4xLED E14/E12 470lm

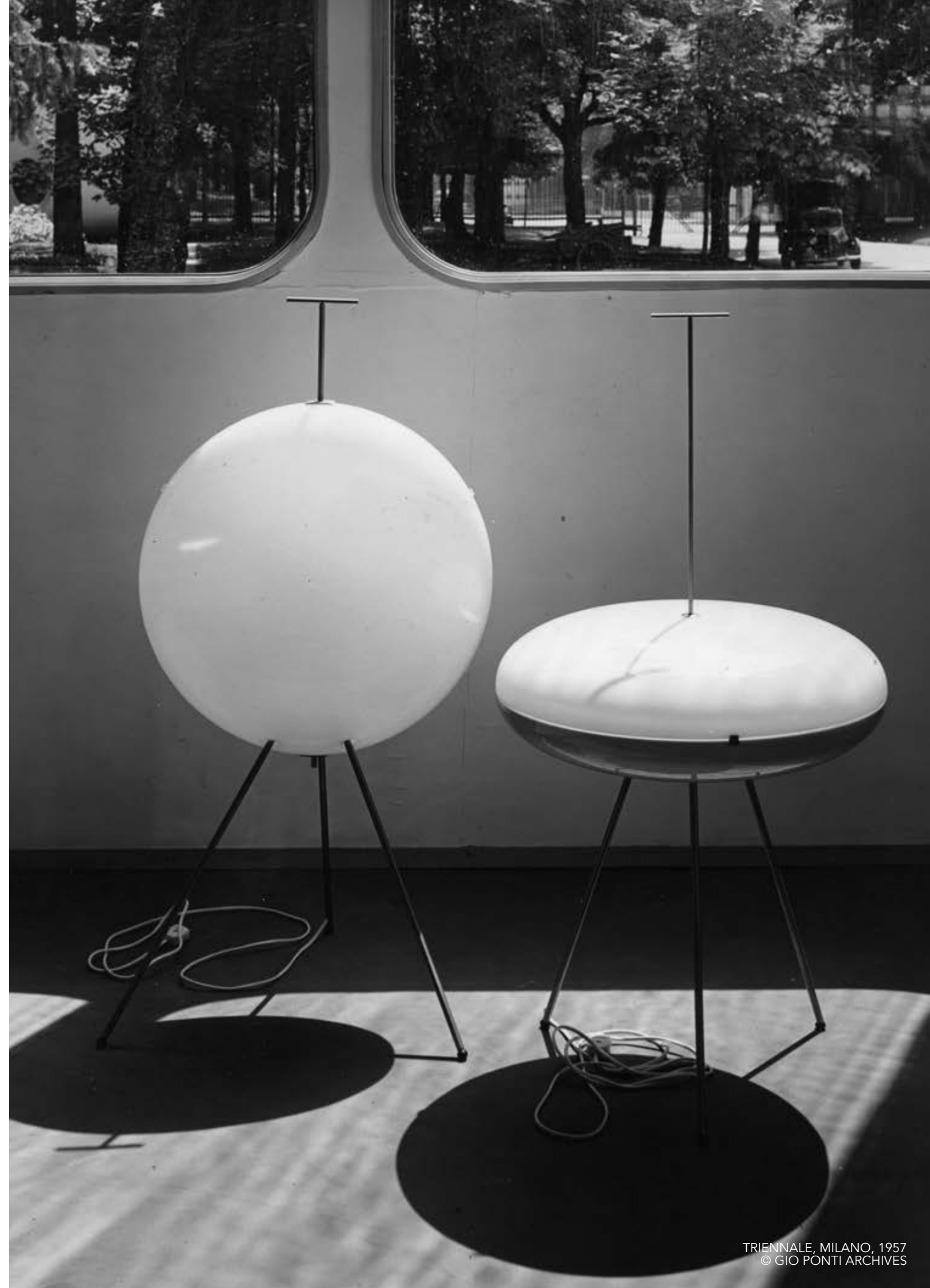
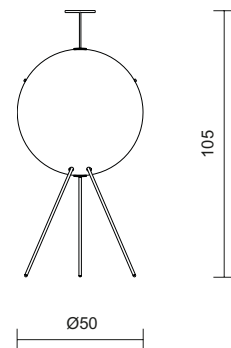

# Netta

designed by Antonia Astori  
2016

## Details

Materials: iron / brass / glass  
Insulation: class II / IP20  
Bulbs: 1xLED E27/E26 806lm

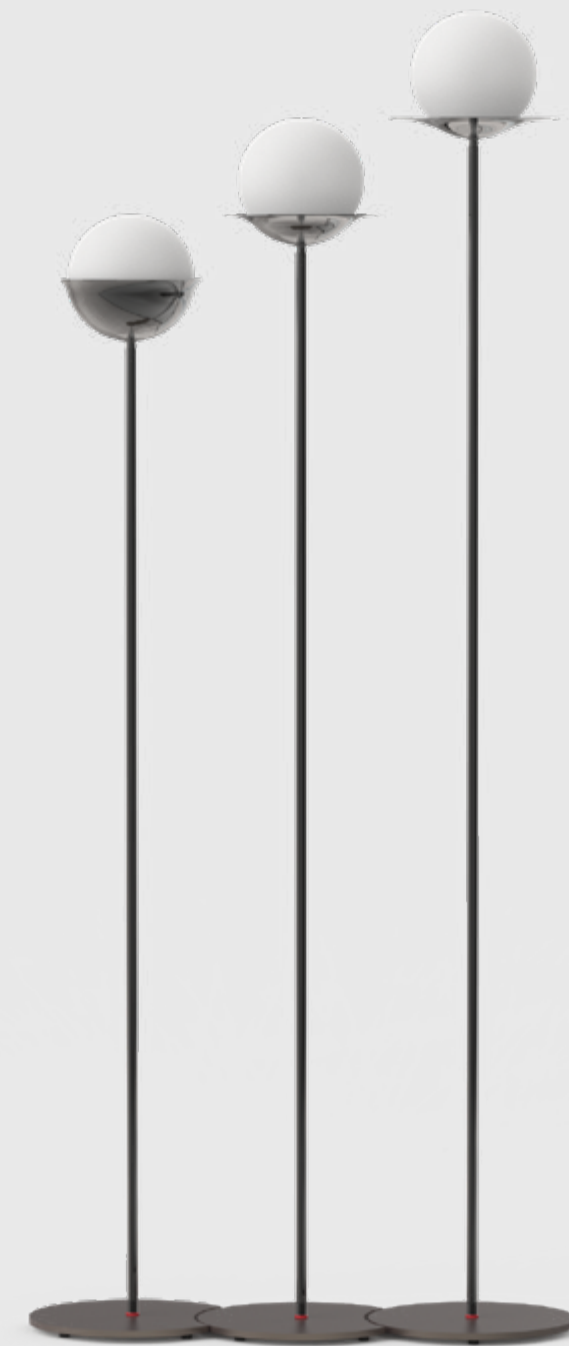



## Models



## Finishings

### Body



### Manganese grey base

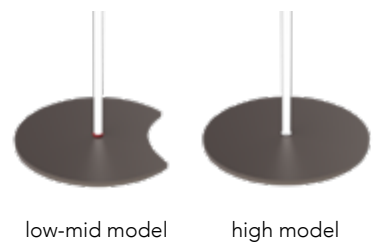

### Shade



## Netta Piantana

Type: floor lamp  
Weight: 8 Kg

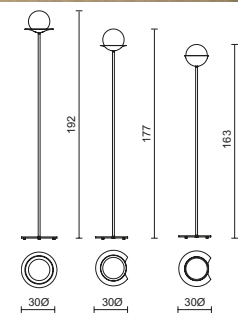

## Netta Sospensione

Type: ceiling lamp  
Weight: 2 Kg

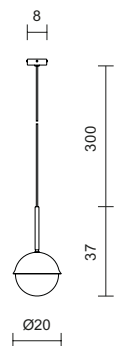

# Olly

designed by Lorenza Bozzoli  
2016



## Details

Materials: brass / glass  
Insulation: class II / IP20

## Models

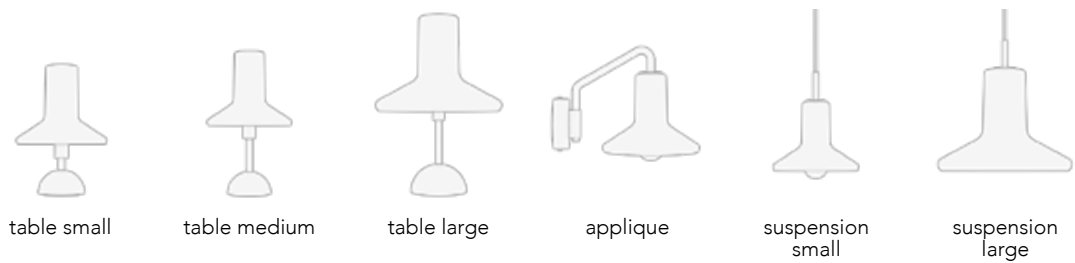

## Finishings

### Body



### Shade



## Olly Tavolo

Type: floor lamp  
 Weight: 1,5 / 3,5 Kg  
 Bulbs: 1xLED G9 400lm

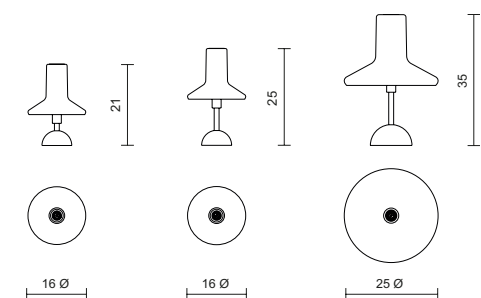



### Olly Applique

Type: applique lamp  
 Weight: 0,7 Kg  
 Bulbs: 1xLED E14/E12 470lm

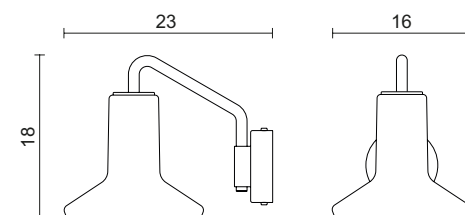

### Olly Sospensione

Type: ceiling lamp  
 Weight: 0,5 Kg  
 Bulbs: 1xLED E14/E12 470lm

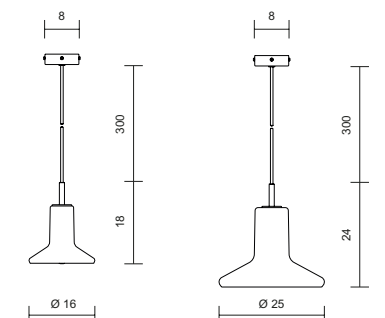



# Orsola

designed by Lorenza Bozzoli  
2016

## Details

Type: table lamp  
Materials: marble / brass / fabric  
Weight: 8 kg  
Insulation: class II / IP20  
Bulbs: 3xLED E14/E12 470lm

## Measurements

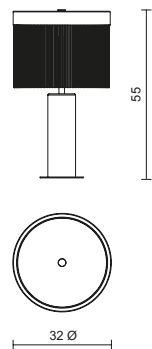

## Finishings

### Metallic structure



brass

black chrome

satin bronze

### Marble base



carrara

marquina

### Fabric fringes



white



# Pagoda Applique

designed by Ignazio Gardella  
1958 / 2023

## Details

Type: wall lamp  
Materials: aluminum / iron  
Weight: 12 Kg  
Insulation: class II / IP20  
Bulbs: 1xLED max 20W E27 2300lm

## Measurements

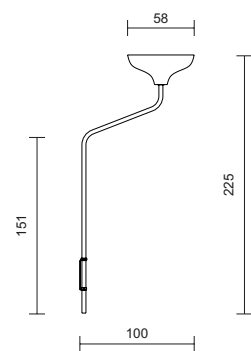

## Finishings

### Body

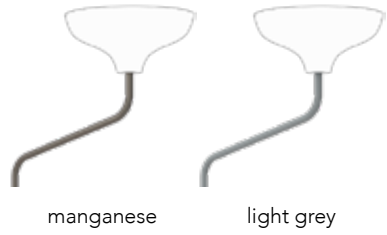

### Shade





# Pagoda Piantana

designed by Ignazio Gardella  
1958 / 2023

*Bold floor lamp built with strong materials and finishings, suitable for indoor and outdoor use.*

## Details

Type: outdoor-proof floor lamp  
Materials: aluminum / iron / stone  
Weight: 46 Kg  
Insulation: class II / IP65  
Bulbs: 1xLED max 20W E27 2300lm

## Measurements

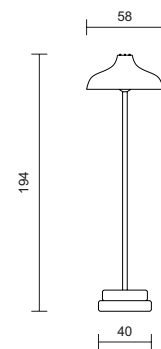

## Finishings

### Body and shade



terracotta

green-grey

---

### Base



sandstone

---



# Paolina

designed by Ignazio Gardella  
1958 / 2021

## Details

Type: ceiling lamp  
Materials: plastic / iron / brass  
Weight: 5 kg  
Insulation: class I / IP20  
Bulbs: 1xLED E27/E26 2300lm

## Measurements

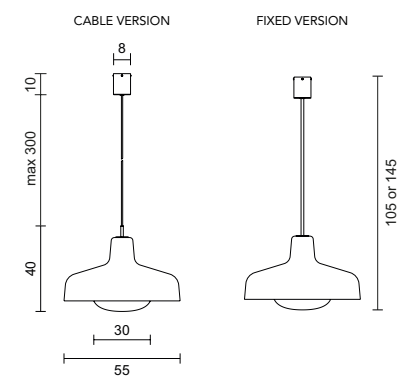

## Finishings

### Wall attachment

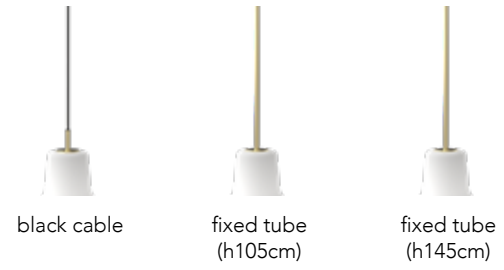

### Accents



### Polycarbonate shade





# Prisma

designed by Ignazio Gardella  
1960 / 2024

## Details

Materials: brass / marble / fabric  
Insulation: class II / IP20



## Models



prisma



cubo

## Finishings

### Body

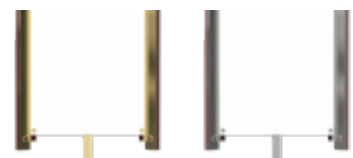

brass

chrome

### Base



carrara



marquina

### Fabric shade



white popeline



## Prisma

Type: floor lamp  
Weight: 30 Kg  
Bulbs: 8xLED E27/E26 806lm

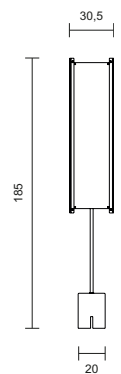



**Cubo**

Type: floor lamp  
 Weight: 25 Kg  
 Bulbs: 4xLED E27/E26 806lm

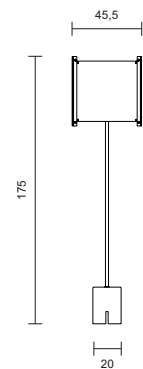

# Siderea

designed by Alberto Rosselli  
1969 / 2018

## Details

Type: table lamp  
Materials: iron / glass  
Weight: 5 kg  
Insulation: class II / IP20  
Bulbs: 1xLED E27/E26 680lm with silver cap

## Measurements

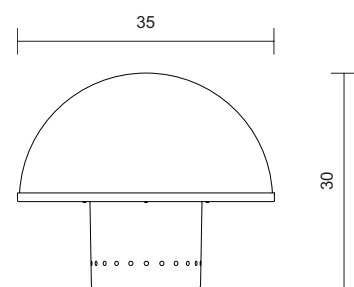



## Finishings

### Body



manganese

---

### Glass shade



crystal

---



# Varesina

designed by Matteo Nunziati  
2021

## Details

Type: ceiling lamp  
Materials: brass / iron / aluminum  
Insulation: class I / IP20



## Models



small



medium



triple



large

## Finishings

### Structure

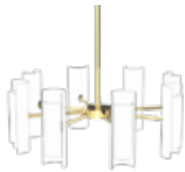

brass

### Shades

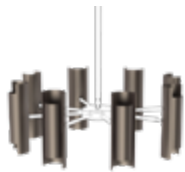

manganese

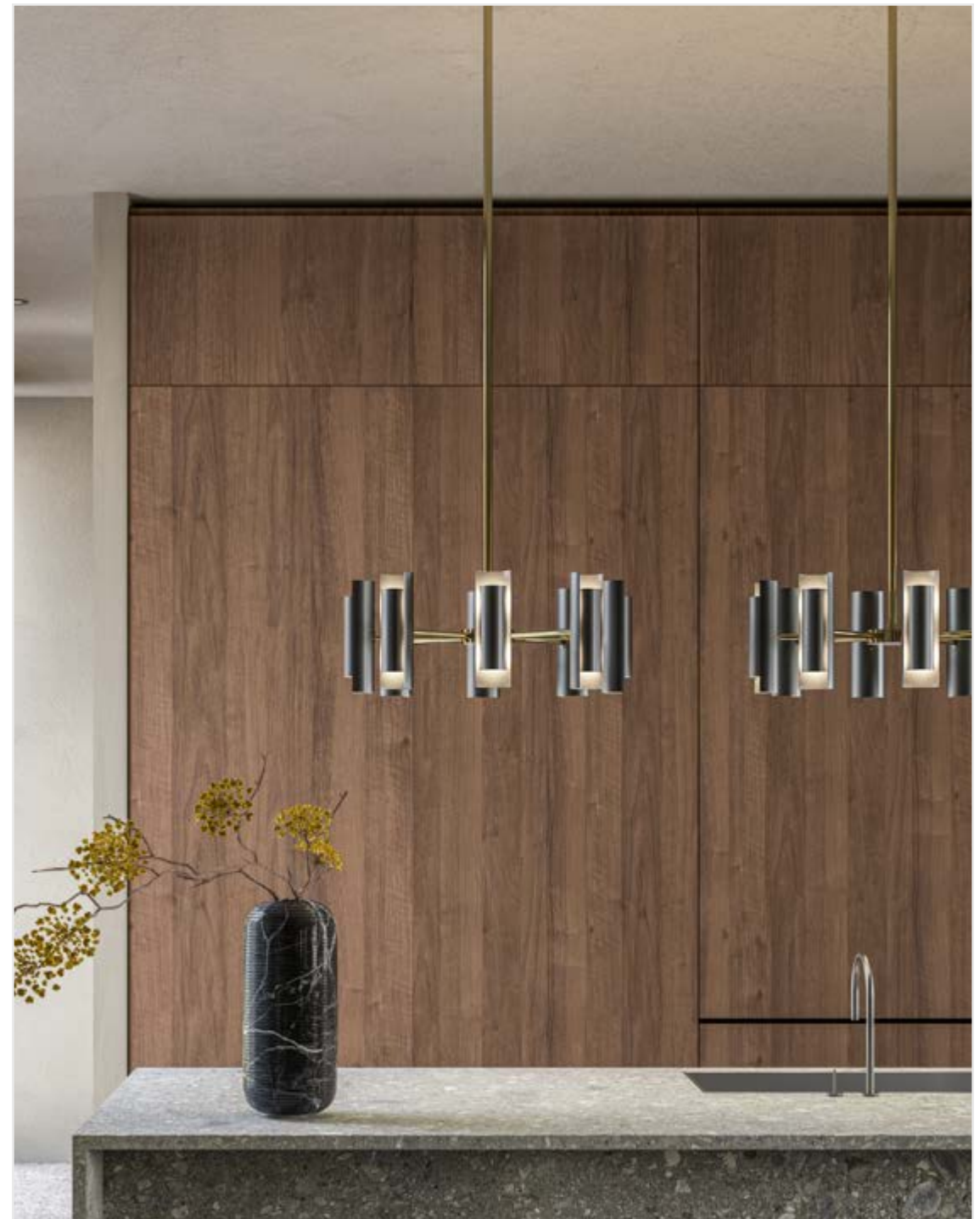

### Varesina Small

Type: ceiling lamp  
Weight: 10 Kg  
Bulbs: 16xLED GU10 250lm

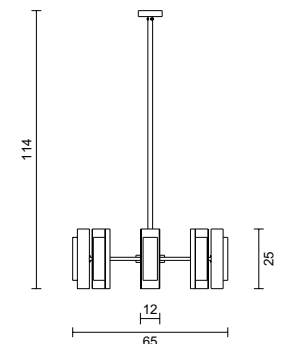



### Varesina Medium

Type: ceiling lamp  
 Weight: 18 Kg  
 Bulbs: 32xLED GU10 250lm

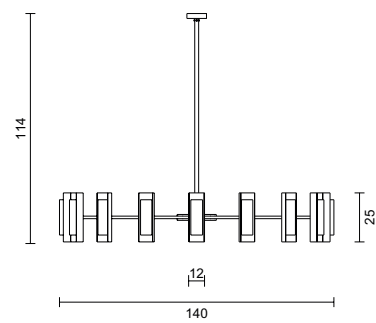

### Varesina Triple

Type: ceiling lamp  
 Weight: 36 Kg  
 Bulbs: 64xLED GU19 250lm

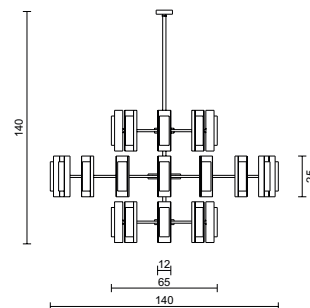

### Varesina Large

Type: ceiling lamp  
 Weight: 50 Kg  
 Bulbs: 32xLED Custom COB

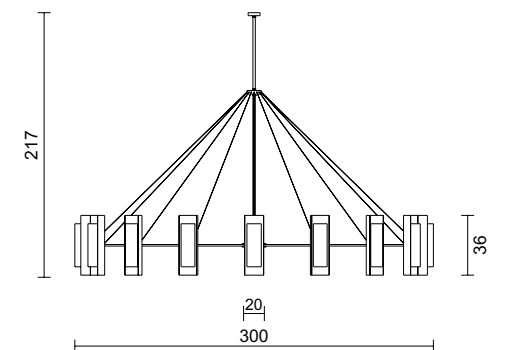



# Vox

designed by Lorenza Bozzoli  
2016



## Finishings

### Height



table low (40cm)    table high (46cm)    wall/ceiling

### Shade



glossy white    glossy black    glossy green    glossy blue    satin brass    brass    satin bronze

### Accents (table model)



brass    chrome    satin brass    satin bronze

### Marble base (table model)



carrara    marquina    emperador    emperador dark    portoro

### Canopy (wall/ceiling model)



satin brass    glossy white    glossy black



Type: table lamp  
 Materials: marble / brass or aluminum  
 Weight: 2,5 Kg  
 Insulation: class II / IP20  
 Bulbs: 1xLED E27/E26 806lm

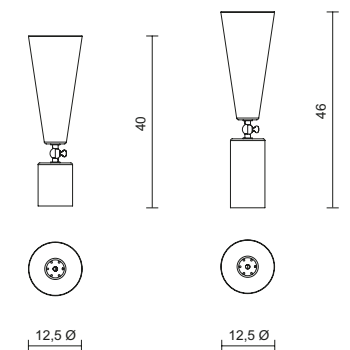



Type: wall/ceiling lamp  
 Materials: brass or aluminum  
 Weight: 0,5 Kg  
 Insulation: class I / IP20  
 Bulbs: 1xLED GU10 450lm

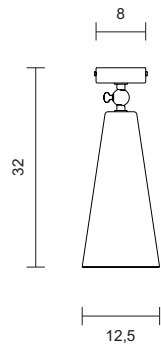

# Wallie

designed by Lorenza Bozzoli  
2014 / 2015

## Details

Materials: brass / aluminum / iron / marble  
Insulation: class II / IP20





## Models



## Finishings

### Structure

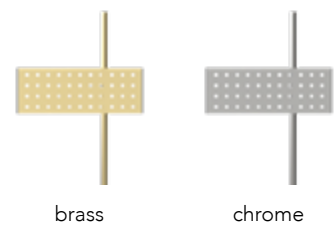

### Lacquered plates



## Wallie Tavolo

Type: table lamp  
Weight: 6,5 Kg  
Bulbs: 2xLED G9 400lm

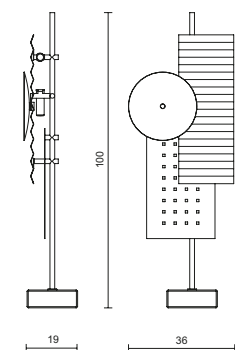



### Wallie Piantana

Type: floor lamp  
 Weight: 8,5 Kg  
 Bulbs: 1xLED E27/E26 2300lm

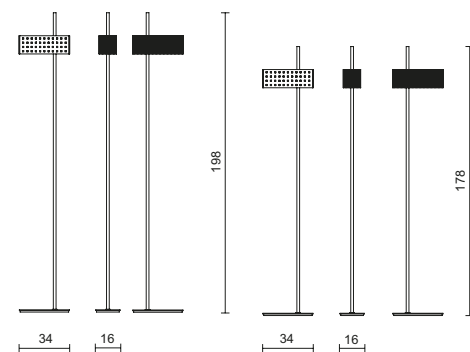

### Wallie Applique

Type: wall lamp  
 Weight: 3,4 Kg  
 Bulbs: 2xLED G9 400lm

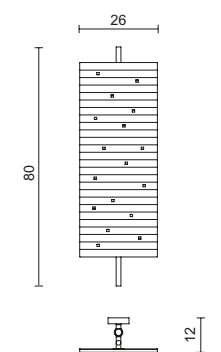



WHITE VERSION



### Wallie Chandelier

Type: ceiling lamp  
 Weight: 12 Kg  
 Bulbs: 1xLED E27/E26 806lm + 3xLED G9 400lm

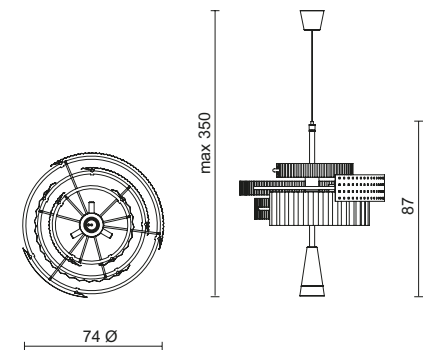

### Wallie Scultura

Type: wall lamp  
 Weight: 23 Kg  
 Bulbs: 5xLED G9 400lm

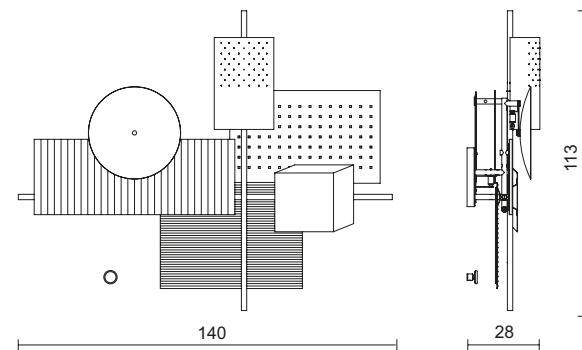







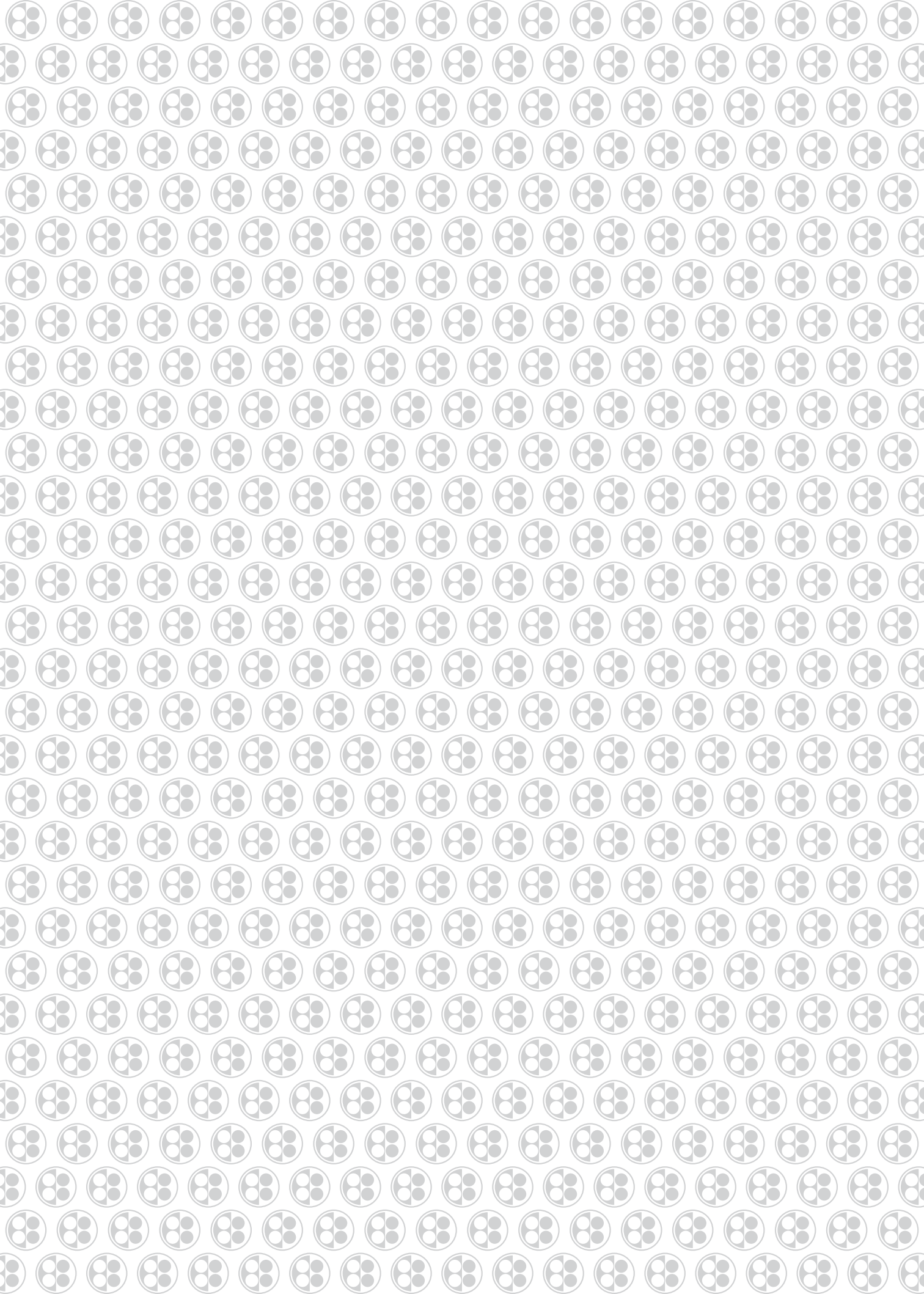

**FURNITURE**

# Acca

designed by Alessandro Pasinelli  
2021

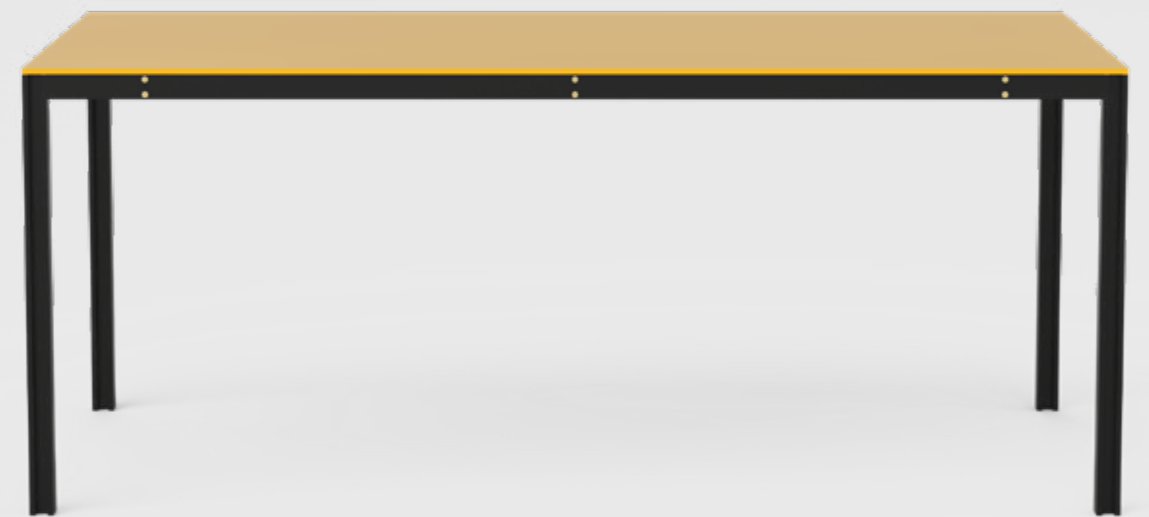

## Details

Type: table  
Materials: iron (base) / glass, wood or marble (top)

## Models



table

coffee table

low table

## Finishings

### Body



matte black

satin gold

satin silver



black screws

gold screws

silver screws

### Top

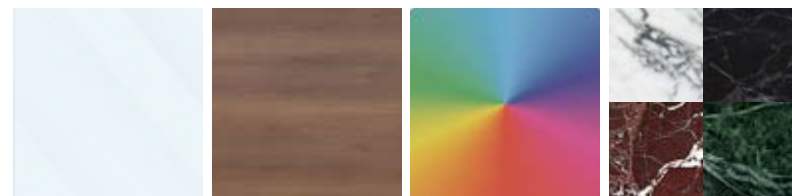

glass

satin walnut

lacquered wood

marble selection



## Acca Table

Type: dining table / desk

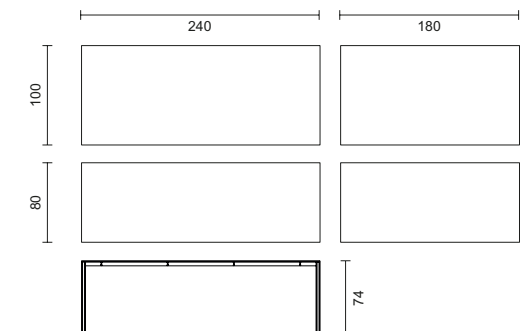



**Acca Coffee Table**

Type: coffee / side table

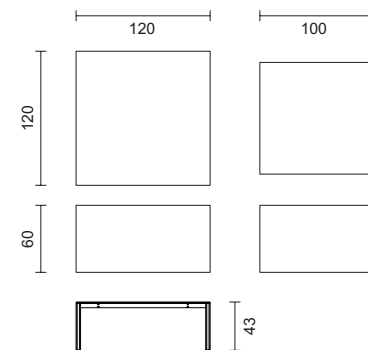

**Acca Low Table**

Type: coffee / side table

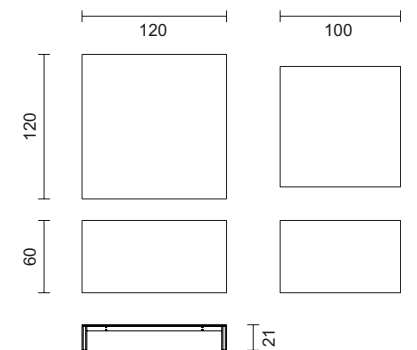







# Angolo

designed by Corrado Corradi Dell'Acqua  
1963 / 2018



## Details

Type: armchair / pouf  
Materials: wood / foam / fabric  
Weight: 14 ~ 17 Kg

## Measurements

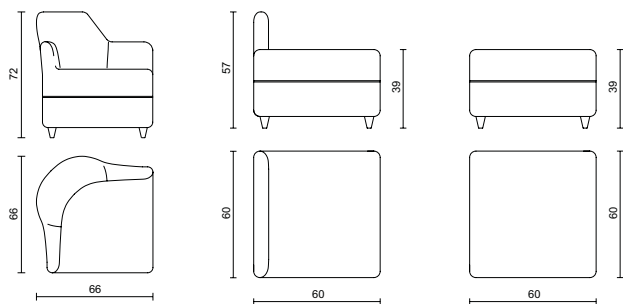

## Models



armchair

pouf w/backrest

pouf

## Upholstery

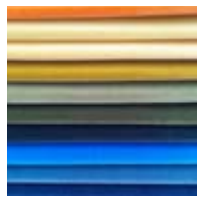

page 324









# Domus

designed by Ignazio Gardella  
1941 / 2024

## Details

Type: console  
Materials: wood / marble  
Weight: 45 Kg

## Measurements

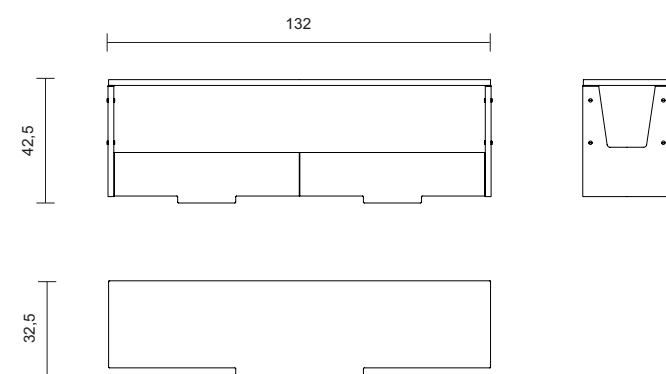



## Finishings

### Body



satin walnut

---

### Top

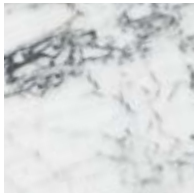

carrara marble

---







Ezra Stoller





# Fagiolo

designed by Atelier TATO, based on *Lido* project  
2023

## Details

Type: sofa  
Materials: wood / foam / fabric  
Weight: 26 Kg

## Measurements

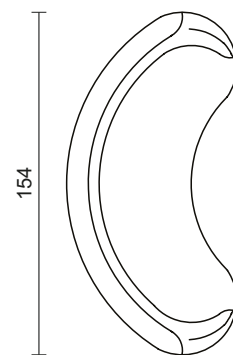
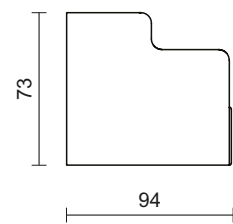



# Libreria Modulare

designed by Ignazio Gardella  
1955 / 2021



## Details

Type: bookshelf  
Materials: iron / brass / wood

## Measurements

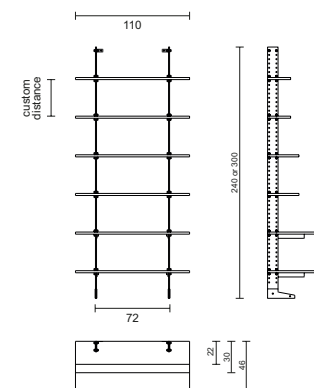



## Models

### Proposed combinations

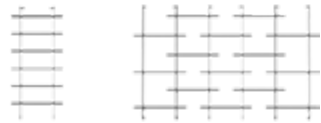

single module

triple module

### Structure finishing

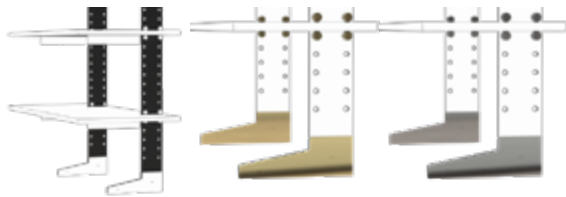

matte black

brass accents

chrome accents

### Shelves depth

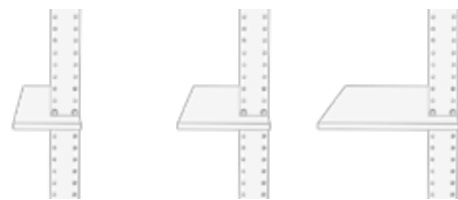

22cm

30cm

46cm

### Shelves finishing

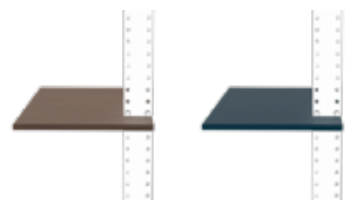

satin walnut

lacquered wood



# Lido

designed by Ignazio Gardella  
1965 / 2019

## Details

Type: armchair / sofa  
Materials: wood / foam / fabric  
Weight: 18 / 25 Kg

## Measurements

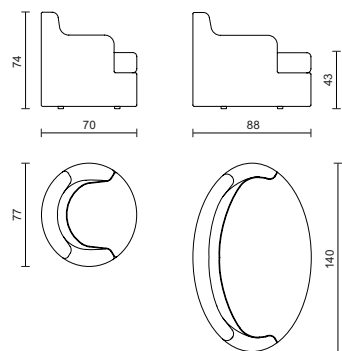

## Models

### Armchair



armchair



sofa

### Upholstery



page 324

### Options

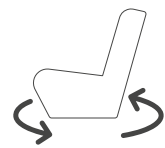

swivel movement







# Monforte

designed by Alessandro Pasinelli  
2021

## Details

Type: lounge chair  
Materials: iron / wood / foam / fabric  
Weight: 8 Kg

## Measurements

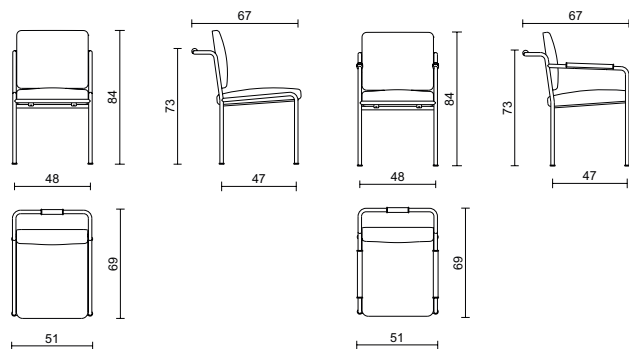

## Finishings

### Models



### Body



### Leather armrests



### Feet and accents



### Upholstery



page 324





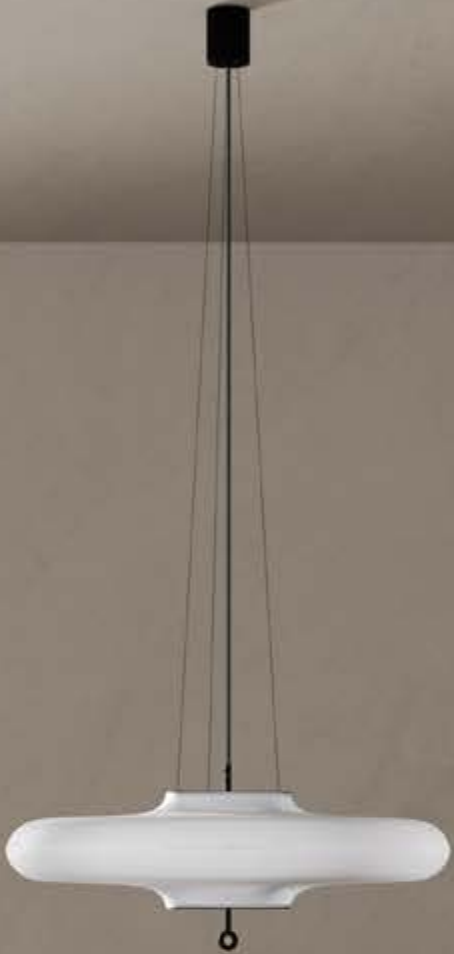
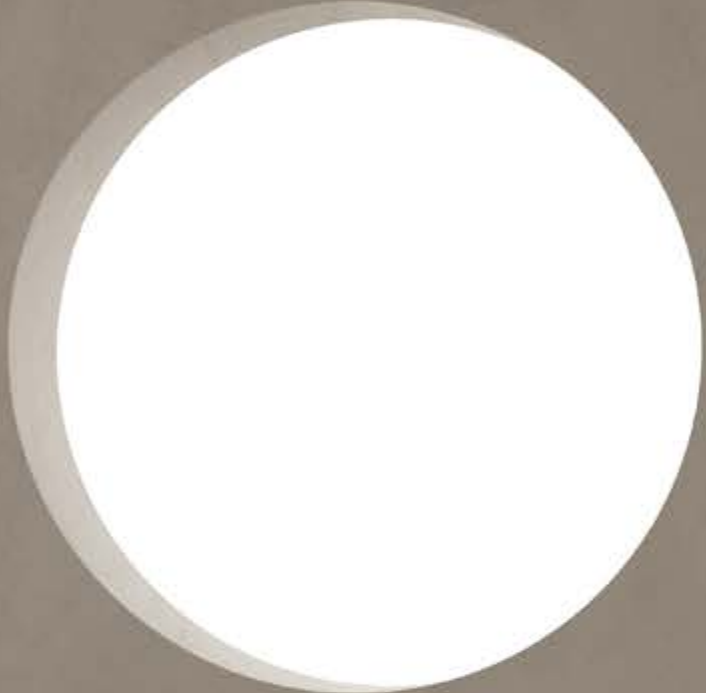

# Montecarlo

designed by Corrado Corradi Dell'Acqua  
1959 / 2019

## Details

Type: side table  
Materials: brass / glass  
Weight: 7 ~ 14 Kg

## Measurements

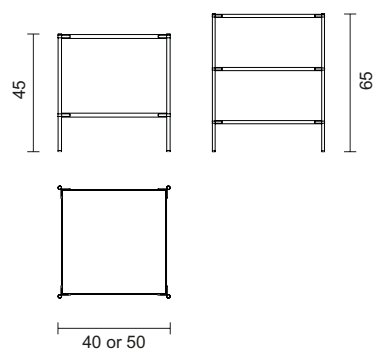

## Finishings

### Models



40x40cm  
2 shelves

50x50cm  
2 shelves

40x40cm  
3 shelves

50x50cm  
3 shelves

### Finishing



brass

chrome





# Piedi Regolabili

designed by Ignazio Gardella  
1951 / 2018

## Details

Type: table  
Materials: iron / brass / wood

## Measurements

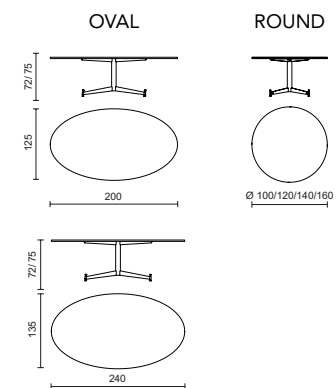

## Models



## Finishings

### Base



### Feet

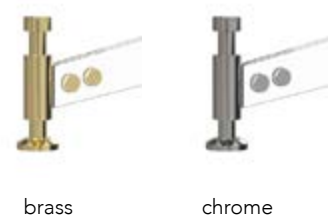

### Top

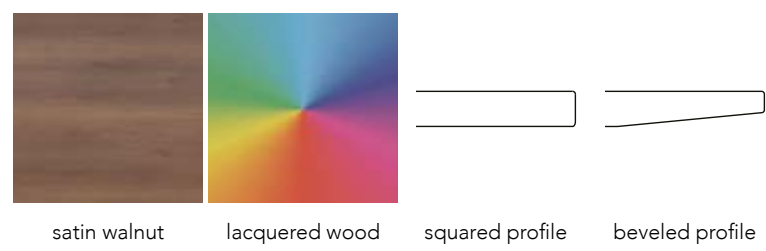







# R63

designed by Ignazio Gardella  
1963 / 2021

## Details

Type: armchair  
Materials: wood / foam / fabric

## Measurements

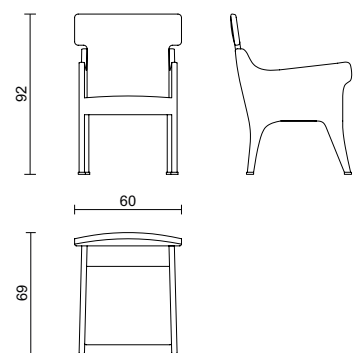



# Sella

designed by Corrado Corradi Dell'Acqua  
1961 / 2021

## Details

Type: pouf  
Materials: wood / foam / fabric

## Measurements

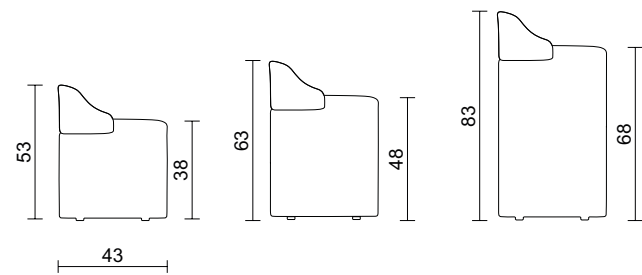



## Models

### Seat height



### Upholstery

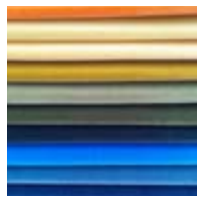

page 324

### Options

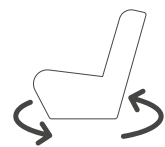

swivel movement

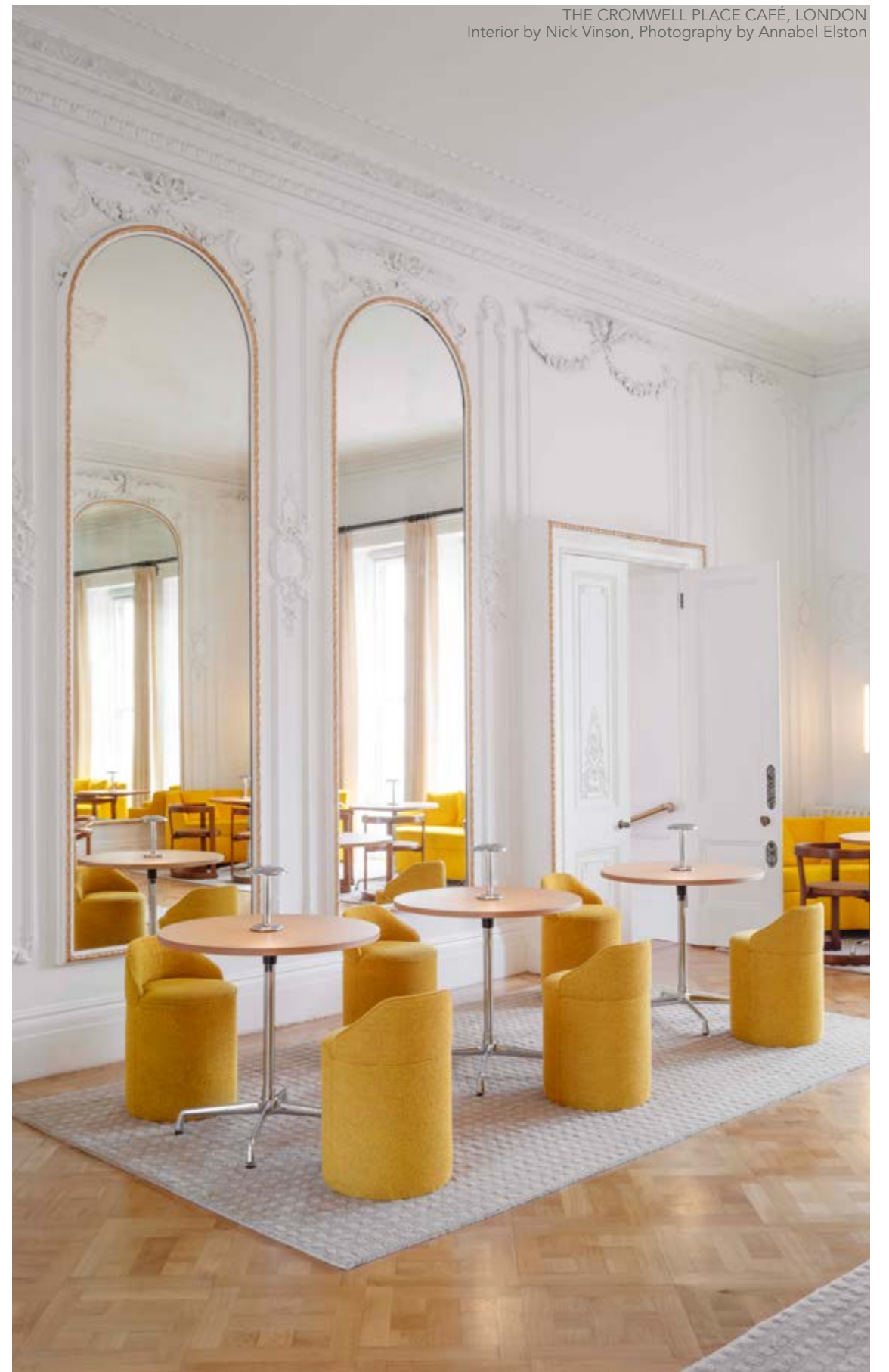

# Stand

designed by Ignazio Gardella  
1952 / 2021

## Details

Type: side table  
Materials: marble / brass / wood

## Measurements

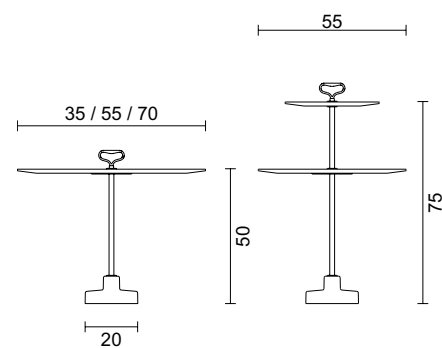

## Finishings

### Models

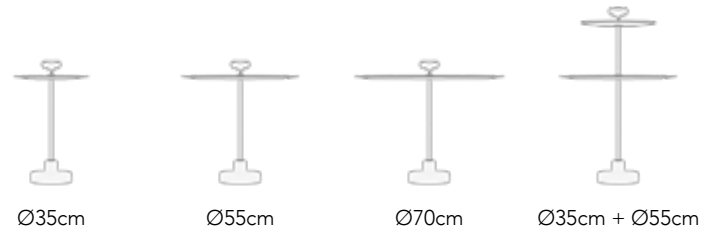

### Tabletop



### Body and handle

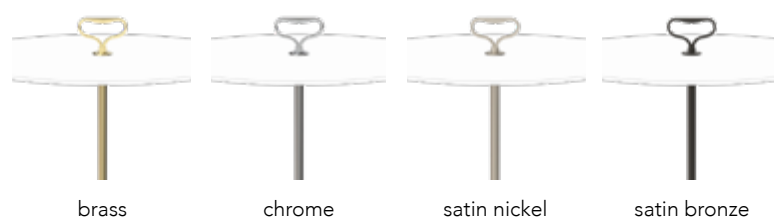

### Marble base







BORSALINO STAND, XXX FIERA DI MILANO, 1952  
© ARCHIVIO STORICO GARDELLA



# Tre Maniglie

designed by Corrado Corradi Dell'Acqua  
1953 / 2021

## Details

Type: trolley  
Materials: brass / formica wood or glass

## Measurements

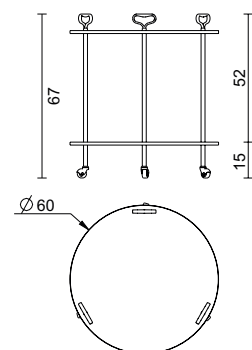

## Finishings

### Tops



formica wood  
(black)



lacquered  
(any color)



glass

### Body and handles



brass



chrome





# Trecentosessanta

designed by Eugenio Gerli  
1958 / 2017

## Details

Type: lounge armchair  
Materials: wood / foam / fabric  
Weight: 9 Kg

## Measurements

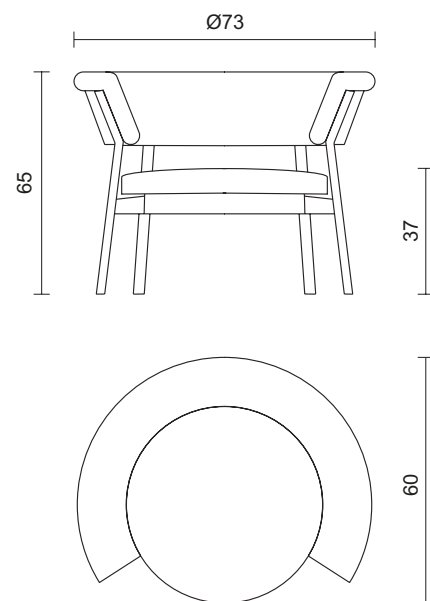

## Structure



brown durmast

black durmast

## Upholstery



page 324

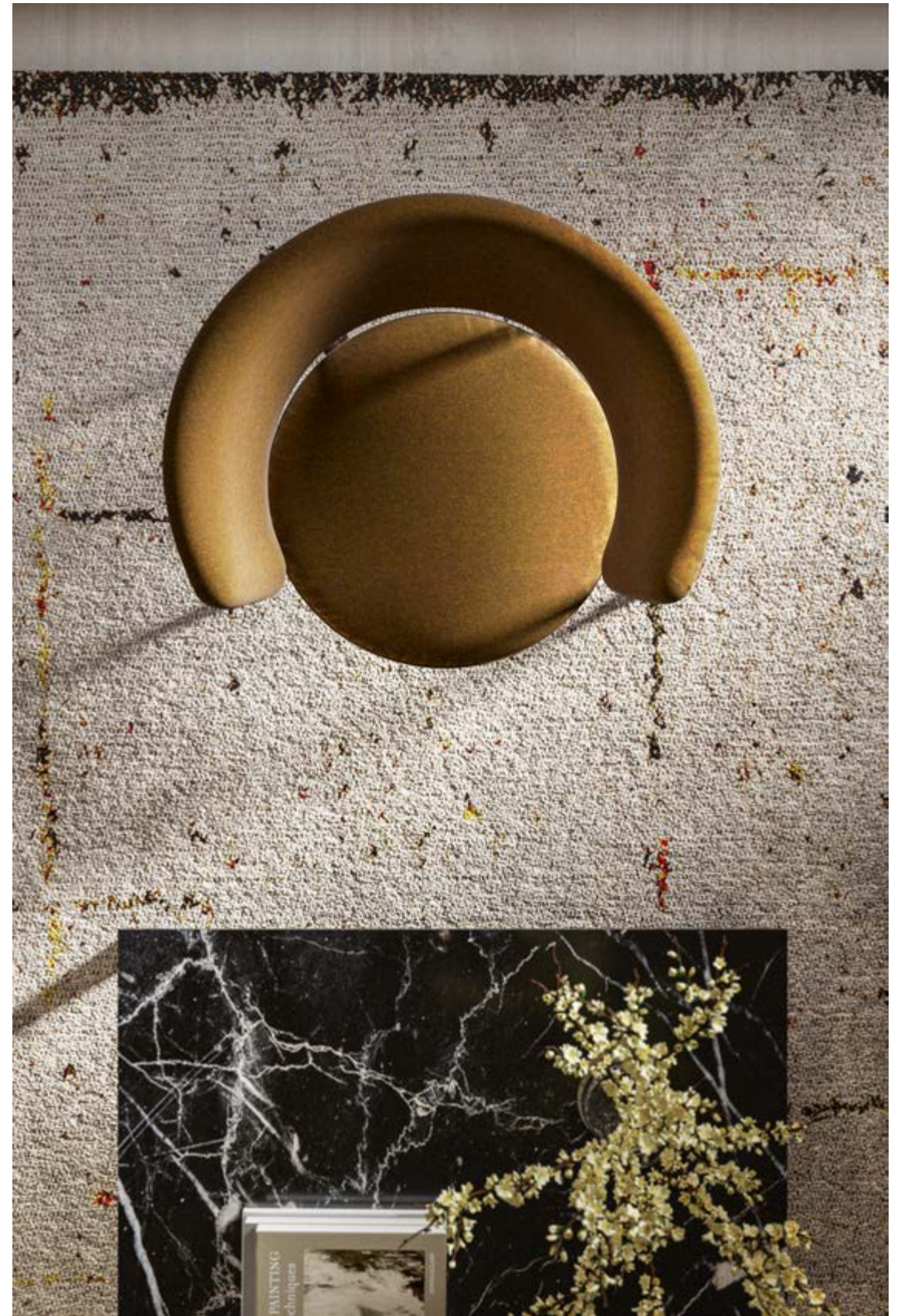







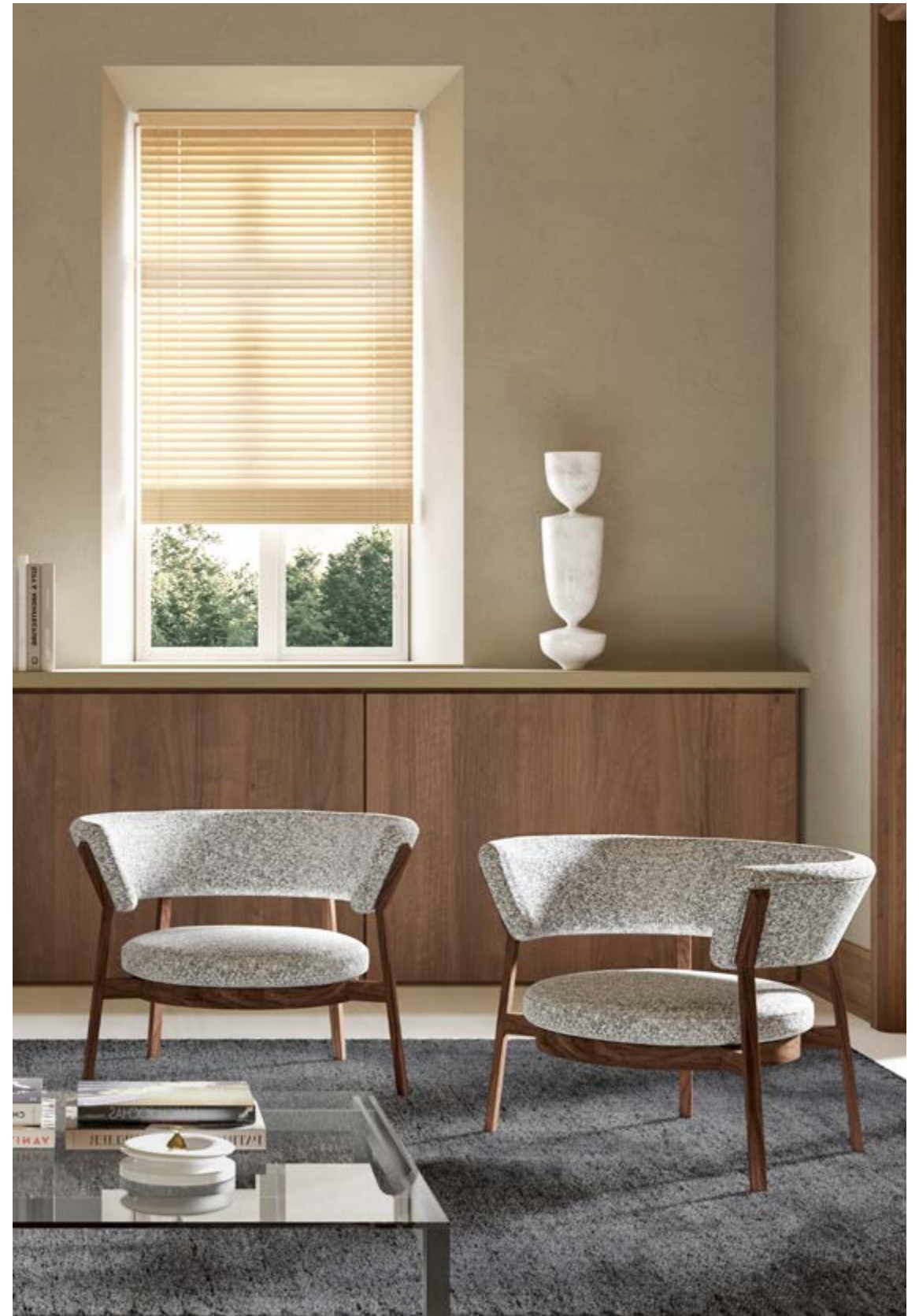

# Truno

designed by Corrado Corradi Dell'Acqua  
1960 / 2021

## Details

Type: sofa  
Materials: wood / foam / fabric

## Measurements

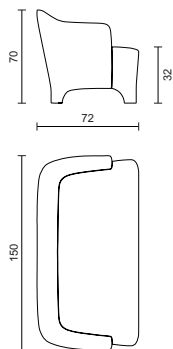





# Zoagli

designed by Studio2046  
2023

*Broad collection of metallic furniture,  
treated with outdoor-proof finishings,  
but also suitable for indoor use.*



## Details

Type: outdoor & indoor collection  
Materials: iron / marble / foam and fabric

## Models

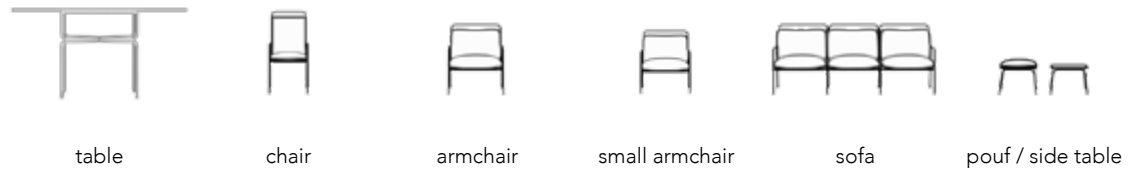

## Finishings

### Structure

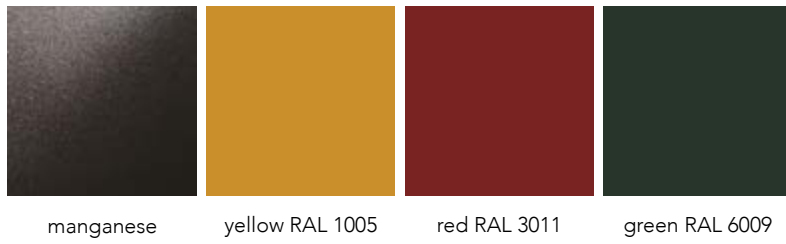

### Marble tabletop

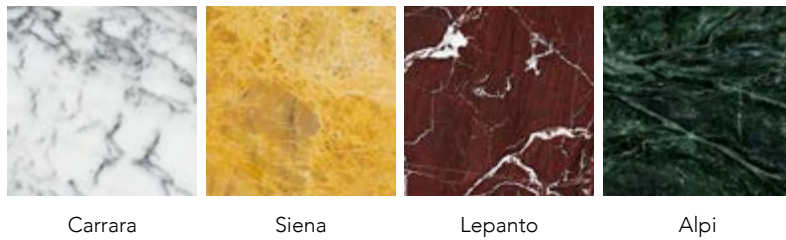

### Upholstery for seats: *Farniente* by Dedar (water repellent)



### Upholstery for seats: *Patio* by Kvadrat (water draining)

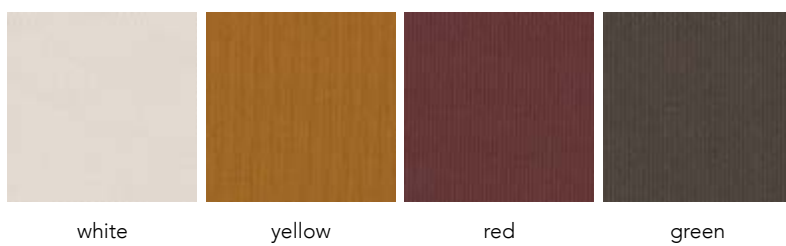

## Table

Type: outdoor-proof dining table

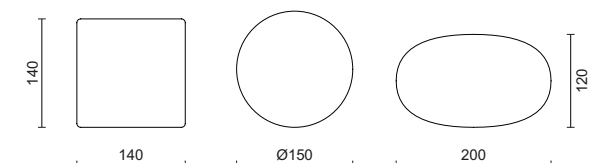





**Chair**

Type: outdoor-proof dining chair

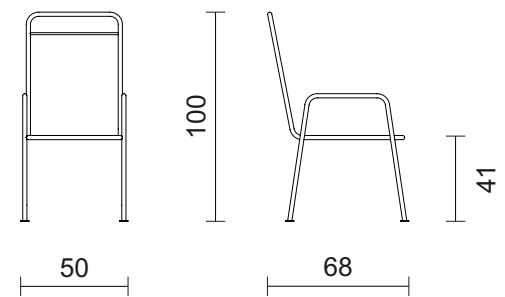

**Sofa**

Type: outdoor-proof sofa

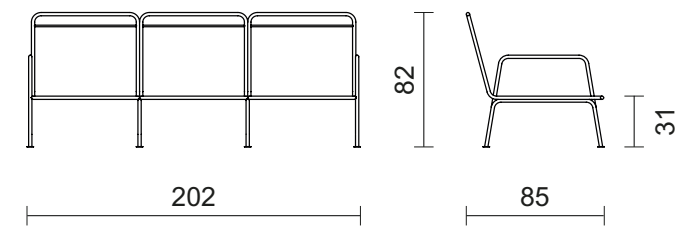





**Armchair**

Type: outdoor-proof armchair

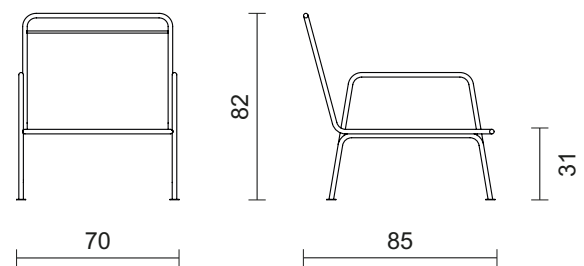

**Small armchair**

Type: outdoor-proof armchair

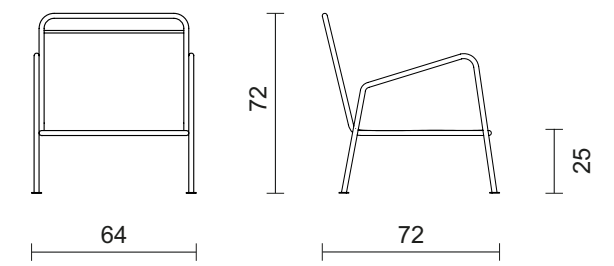

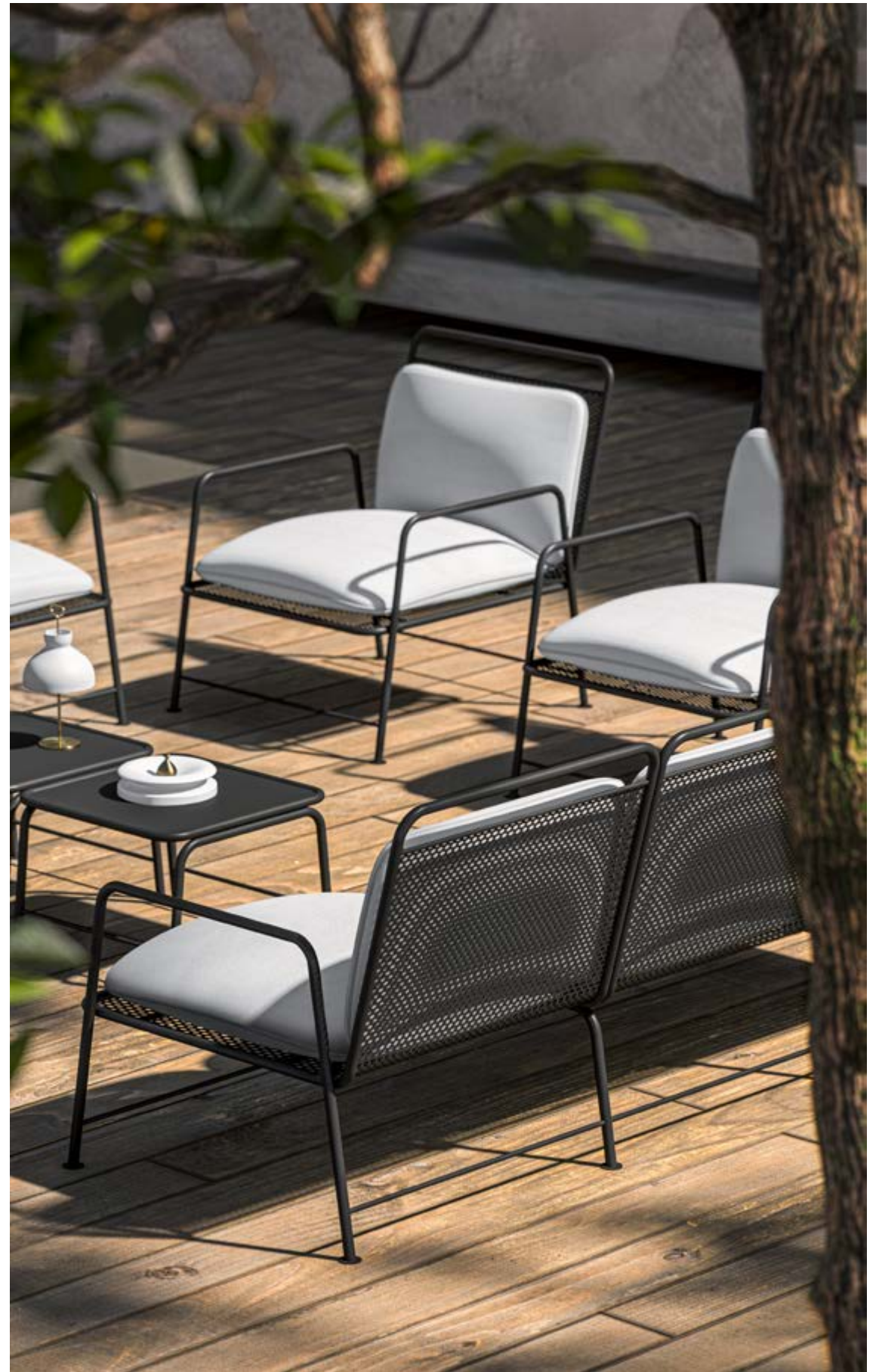

**Pouf**

Type: outdoor-proof pouf / side table

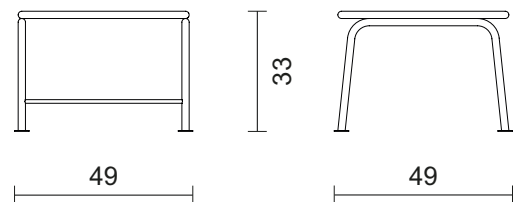







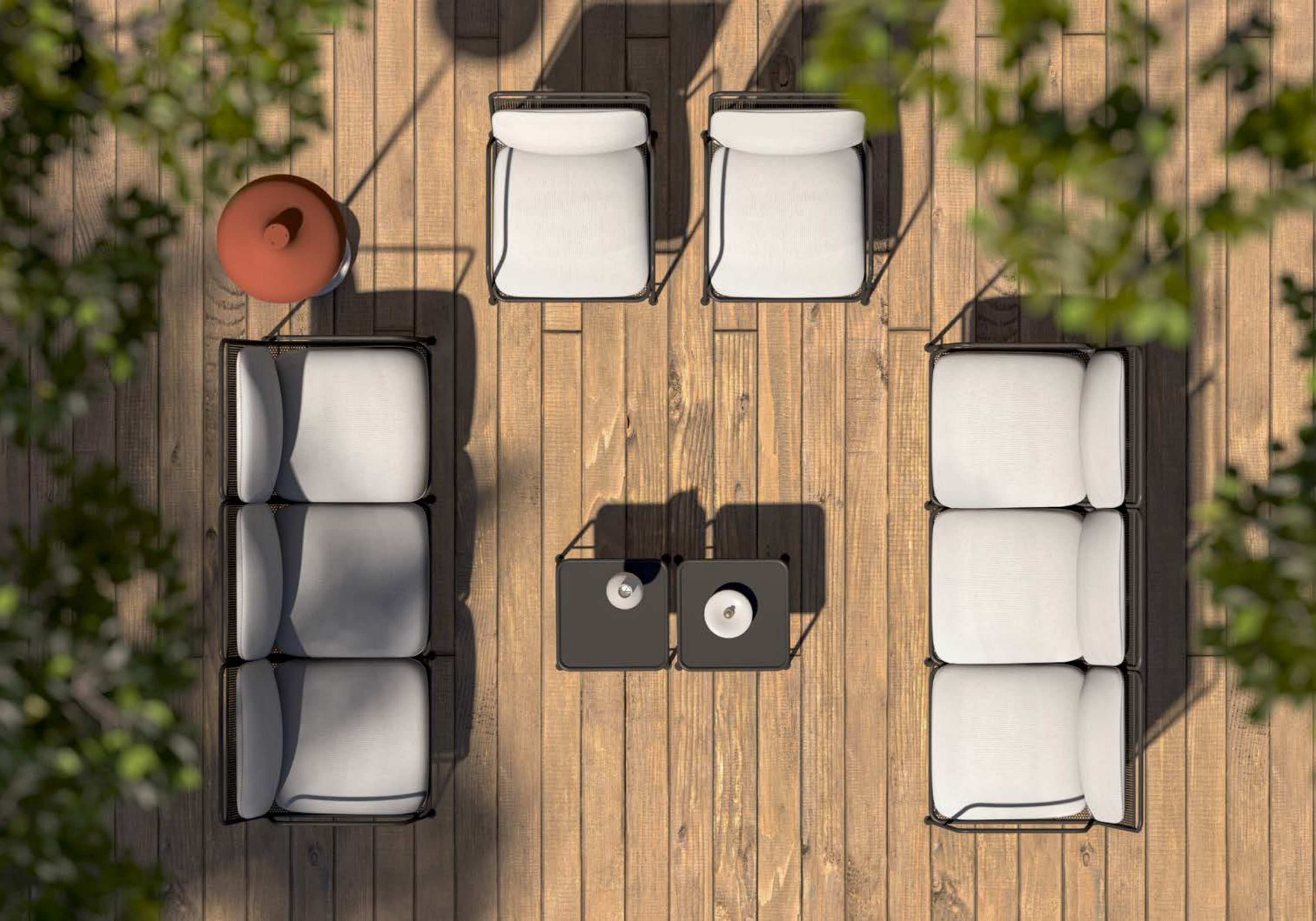







## Products



Domus console  
TDO600-1538  
walnut/Carrara marble



Lido armchair  
TFA600-3800  
custom leather



Stand side table 55cm  
TST610-0916-G  
brass/black marble/glossy top



Coppa Aperta Applique lamp  
TCA200-0924  
brass/glossy black





## Products



Besana lamp  
TBS100-3565  
matte black



Monforte chair  
TSM600-3500  
matte black/custom fabric



Piedi Regolabili oval table  
TPR603-0935  
brass feet/glossy top



Pestello ashtray  
TCC980-1511  
Sivec marble/brass





## Products



Domus console  
TDO600-1538  
walnut/Carrara marble



Fagiolo sofa  
TFA600-3800  
custom fabric



Stand side table 55cm  
TST610-0916-S  
brass/black marble/satin top



Prisma lamp  
TPS400-0915  
brass/Carrara marble



## Products



Prisma Cubo lamp  
TPS410-0915  
brass/Carrara marble



Piedi Regolabili round table  
TPR614-0935  
brass feet/satin top



Sella pouf medium  
TSE610-38CC  
Rubelli Nexus

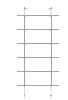

Modulare bookshelf  
TLM600-0935  
custom modules/brass/h240cm



Ampolla Alta vase  
TCC942-3132  
platinum





**Products**



Besana lamp  
TBS100-3565  
matte black



Monforte chair  
TSM600-13CC  
gold/Rubelli Scott



Monforte lounge chair  
TSM610-35DD  
black/Kvadrat Hero Heather



Piedi Regolabili oval table  
TPR603-0935  
brass feet/satin walnut top



Domus console  
TDC600-1538  
walnut/Carrara marble



Arezano lamp  
TAR310-0940  
brass/white glass

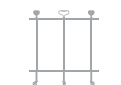

Tre Maniglie trolley  
T3M600-0938  
brass/formica wood



## Products



Alzabile lamp  
TAL400-1523  
glossy white/brass/Carrara marble



Fagiolo sofa  
TFA600-38BB  
Kvadrat Vidar4



Pagoda Applique lamp  
TPG200-2322  
manganese/glossy white



Trecentosessanta armchair  
TTS600-38AA  
durmast/Rubelli Rattoppato



Acca low table  
TTH620-3535  
black base/Carrara marble top



**Products**



Prisma lamp  
TPS400-0915  
brass/Carrara marble



Sella pouf medium  
TSE610-38BB  
Dedar Tiger Beat



Stand side table 70cm  
TST620-0916-W  
brass/black marble/walnut top



Modulare bookshelf  
TLM600-0935  
custom module/brass/h240cm



R63 armchair  
T63600-09BB  
Kvadrat Divina3/brass



Leina lamp  
TLE310-1665  
black marble





## Products



Pagoda Applique lamp  
TPG200-2322  
manganese/glossy white



Trecentosessanta armchair  
TTS600-3800  
durmast/custom fabric



Acca low table  
TTH620-2121  
silver base/black marble top



Stand side table 55cm  
TST610-0116-G  
chrome/black marble/glossy top





**Products**



Doppio Vetro Applique lamp  
TDV200-0140  
chrome



Trecentosessanta armchair  
TTS600-3800  
durmast/custom fabric



Acca low table  
TTH620-2121  
silver base/glass top



Fagiolo sofa  
TFA600-3800  
custom fabric





## Products



Doppio Vetro Sospensione lamp  
TDV110-0940  
brass



Monforte chair  
TSM600-3500  
matte black/custom fabric



Piedi Regolabili oval table  
TPR603-0935  
brass feet/satin walnut top





**Products**

  
 Alzabile lamp  
 TAL400-1501  
 chrome/Carrara marble

  
 Fagiolo sofa  
 TFA600-3800  
 custom fabric

  
 Stand side table 55cm  
 TST610-0115-S  
 chrome/Carrara marble/satin top

  
 Modulare bookshelf  
 TLM600-0935  
 custom module/brass/h240cm





## Products



Coppa Aperta Piantana lamp  
TCA400-1609  
brass/Marquinia marble



Jil lamp  
TJL300-1315  
satin brass/Carrara marble



Acca low table  
TTH621-0606  
gold/walnut top



Montecarlo side table  
TMO610-0909  
brass



R63 armchair  
T63600-0960  
custom fabric/brass



Truno sofa  
TRU600-38BB  
Kvadrat Divina3



Pestello ashtray  
TCC980-1511  
Sivec marble/brass





## Products



Lea lamp  
TLE300-5040  
Portoro marble/white glass



Paolina lamp  
TPL110-0965  
brass/satin white polycarbonate



Monforte lounge chair  
TSM610-3500  
matte black/custom fabric



Piedi Regolabili oval table  
TPR630-0135  
black/chrome feet/satin top





## Products



Coppa Aperta Applique lamp  
TCA200-0924  
brass/glossy black



Icones Piantana lamp  
TIC400-1365  
satin brass/satin nickel



Tre Maniglie trolley  
T3M600-0938  
brass/formica wood



R63 armchair  
T63600-09BB  
Kvadrat Divina3/brass



**Products**



De-Lux B4 lamp  
TDB440-0665  
gold/matte white shade



Angolo armchair & poufs  
TPA600-38BB  
Kvadrat Divina3



Lido armchair  
TLI600-3800  
custom fabric



Stand 70 table  
TST620-0916-W  
brass/marquina marble/walnut



Stand Double table  
TST630-0915-S  
brass/carrara marble/satin lacquer





## Products



Alzabile lamp  
TAL400-1609  
brass/marquimia marble



Lido sofa  
TLI601-38BB  
Kvadrat Divina3



Montecarlo side table  
TMO610-0909  
brass



Rocchetto vase  
TCC932-3231  
dark blue/platinum





**Products**

  
Netta Sospensione lamp  
TNE100-3401  
black chrome

  
Acca dining table  
TTH600-3535  
matte black base/glass top

  
Monforte lounge chair  
TSM610-35BB  
matte black/Kvadrat Divina3





**Products**



Luna Sospensione lamp  
TLU100-0968  
brass/glossy white and orange



Olly Tavolo Medium lamp  
TOL310-1341  
satin brass/satin white glass



Acca dining table  
TTH600-3535  
matte black base/custom top

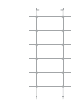

Modulare bookshelf  
TLM600-0935  
single module/brass/h240cm



Monforte lounge chair  
TSM610-3500  
matte black/custom fabric



Pestello ashtray  
TCC980-1511  
Sivec marble/brass





**Products**



Biba Tavolo lamp  
TBI300-3540  
matte black



De-Lux B4 lamp  
TDB440-3565  
matte black/matte white shade



Acca coffee table  
TTH611-0606  
gold base/custom top



Lido armchair  
TLI600-38BB  
Kvadrat Divina3



Lido sofa  
TLI601-3800  
custom fabric

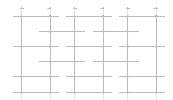

Modulare bookshelf  
TLM630-0935  
triple module/brass/h300cm



Beuta vase  
TCC920-3132  
platinum





## Products



Galleria lamp  
TGA210-0540  
satin nickel



Acca coffee table  
TTH613-2121  
silver base/lepanto marble top



Tre Maniglie trolley  
T3M610-0144  
chrome/glass



Truno sofa  
TRU600-38BB  
Kvadrat Divina3



Products

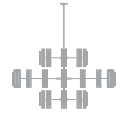

Varesina lamp  
TVA120-0922  
brass/manganese



Piedi Regolabili round table  
TPR605-1335  
gold base/brass feet/glossy top



Ampolla Alta vase  
TCC942-3232  
dark blue





**Products**



Pagoda Piantana lamp  
TPG400-2920  
terracotta/sandstone



Zoagli armchair  
TZO630-3333  
yellow



Zoagli sofa  
TZO620-3333  
yellow



Zoagli pouf  
TZO640-3333  
yellow



Pestello ashtray  
TCC980-1511  
Sivec marble/brass





**Products**



Pagoda Piantana lamp  
TPG400-2920  
terracotta/sandstone



Zoagli armchair  
TZO630-2222  
manganese/white cushions



Zoagli sofa  
TZO620-2222  
manganese/white cushions



Zoagli pouf  
TZO640-2222  
manganese/white cushions



Arezano Wireless lamp  
TAR330-0965  
brass



Pestello ashtray  
TCC980-1511  
Sivec marble/brass





# Fabric proposals



DEDAR Amuleto



DEDAR Farniente

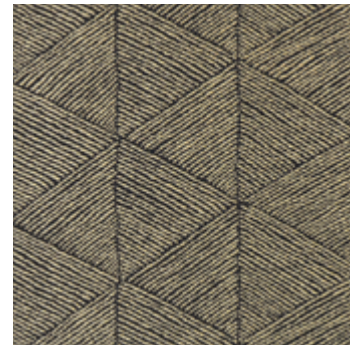

DEDAR Fr Alaya

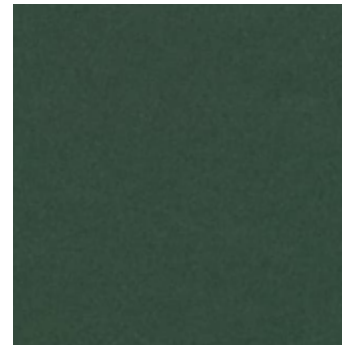

KVADRAT Divina 3



KVADRAT Hero Heather



KVADRAT Maple



DEDAR Lindon R



DEDAR Nimbus



DEDAR Tiger Beat

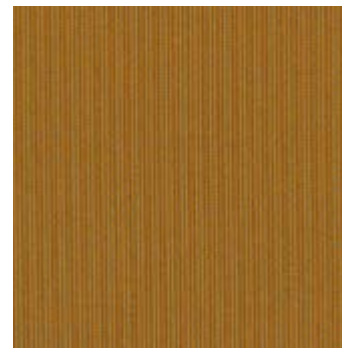

KVADRAT Patio

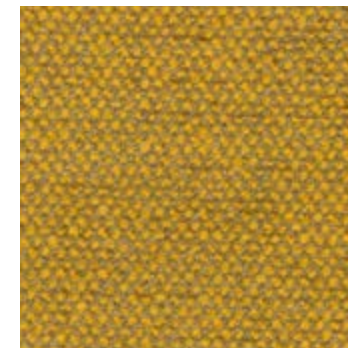

KVADRAT Safire



KVADRAT Steelcut Trio



RUBELLI Derby Toile



RUBELLI Fabthirty



RUBELLI Fabthirty+



KVADRAT Vidar 4



TATO Selection Lario Velvet



TATO Selection Florida Leather

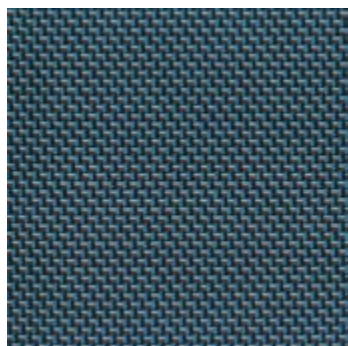

RUBELLI Nexus



RUBELLI Rattoppato



RUBELLI Scott



# Marble



Carrara

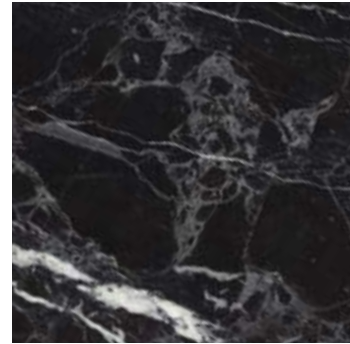

Marquinia

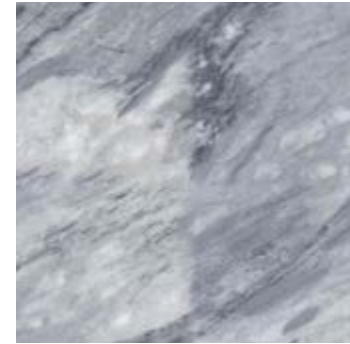

Grey

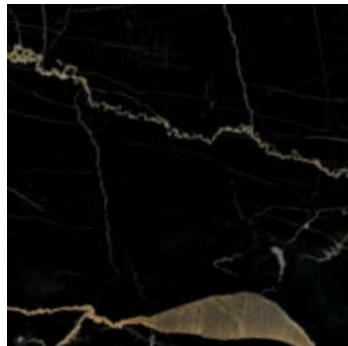

Portoro



Emperador

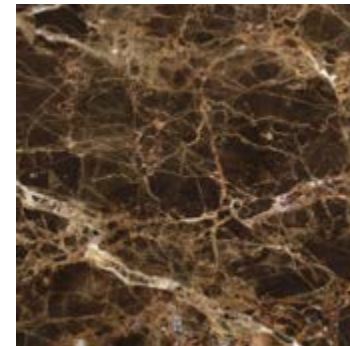

Emperador Dark

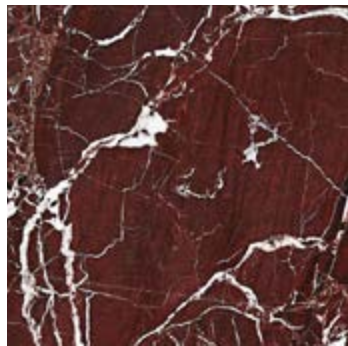

Lepanto



Alpi



Siena

# Wood



Satin walnut



Glossy lacquer  
(RAL Classic chart)



Satin lacquer  
(RAL Classic chart)



Brown durmast



Black durmast

## CREDITS

### **Concept & Styling**

Alessandro Pasinelli Studio

### **Graphic design**

TATO

### **Photos**

Antonio Maniscalco, Tiziano Sartorio, Unidea,  
Davide Arena, Pauliina Salonen, Annabel Elston

### **Image production**

ZoneLab  
TATO

### **Printed by**

Tipografia Testori

### **Special Thanks**

Studio Gardella, Gio Ponti Archives,  
Lorenza Bozzoli Design, Studio Matteo Nunziati,  
Azalea Seratoni Gualdoni

All products, specifications and data could be subject to change  
without notice to improve reliability, function, design or otherwise.  
Pictures and information present on the website and catalogues  
don't have any contractual value.  
All product dimensions are in cm.



All products are according to the EC directives

**©2024 TATO, all rights reserved**

No text, layout or pictures may be used or reproduced for commercial purposes by third parties, including dealers,  
retailers, internet shops and other, without prior approval by TATO.





