



---

CECCOTTICOLLEZIONI

Milano Design Week 2024

---

Concept

---

«Imagination can help us discover  
and pursue our dreams,  
transforming our inner  
visions into tangible realities.»

**Imagine with Poltrona Frau**

---

# 2024 Imagine Collection

---



## **Imagine Softness**

- Squash Collection
- Parka

## **Imagine Versatility**

- Range Extensions
- Duo Dining Collection
- Home-office Collection
- Bedroom Collection
- Upholsteries and Finishings

## **Imagine Reality**

- Fornasetti x Poltrona Frau

## **Imagine Culture meets Craft**

- Ozwald Boateng x Poltrona Frau

## **Imagine Well-Being**

- Beautilities Collection

## **Imagine Boundless Living**

- Mirabell Collection
- Range Extensions
- Upholsteries and Finishings

---

Imagine **Softness**

---

A close-up photograph of a beige leather chair cushion, showing the texture and stitching of the material. The cushion is curved and appears to be part of a larger piece of furniture.

# Squash Collection

Design: Faye Toogood

# Squash Collection | Design by Faye Toogood



**“The importance of design is not just solving problems. It’s also how we feel”**

Faye Toogood is a British artist and designer known for her diverse range of creative work. Her artistic endeavors span various disciplines, including sculpture, furniture design, and fashion.

Her designs are characterized by their sculptural quality, clean lines, and attention to detail.

Toogood’s furniture pieces often blur the boundaries between art and functionality.

She crafts unique, handcrafted items that challenge conventional norms such as the ‘Spade’ chair and the ‘Roly-Poly’ chair achieving iconic status through their strong geometry and form.

# Squash Collection | Concept



“Enveloping like a Soft Coat”



“Contrast of Supple and Firm”



## Faye Toogood

«To create Squash, we worked in our usual Toogood way making dollhouse scale maquettes. Finding the forms in clay, and in canvas, and then covering them in vivid red paint. I think Poltrona Frau appreciated our hand-on, human approach to furniture design.

When I started to show Poltrona Frau images of early English folk pieces, we found there were shapes that mirrored those in their archive in Italy. Shared forms from completely different cultures and contexts. Furniture design is tactile, alive... and it connects us through history»

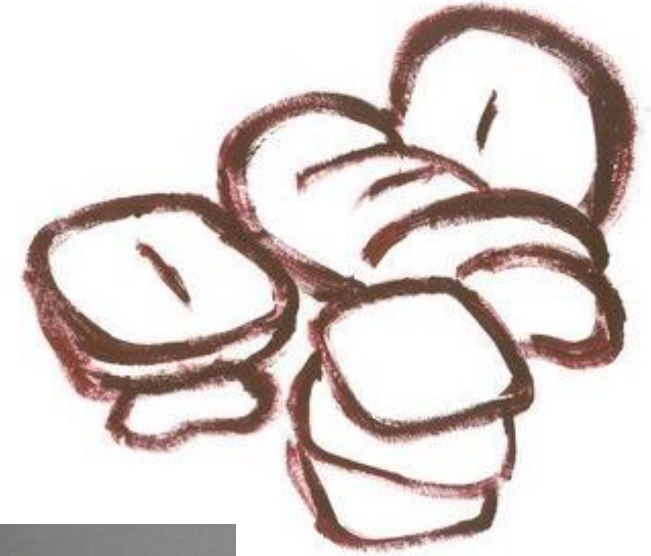

“Stitched and Plump”





## Generous, exuberant, iconic and feminine

- The new vision of the contemporary armchair interpreted by Faye Toogood for Poltrona Frau.
- The contrast between the organic light structure, and a generous cushioning, round and full of soft ripples, creates a strongly distinctive language for the product.
- The main item of the collection is the generous cushion folded inside the structure which design soft curves recalling the image of a cloud.
- Squash naming refers to the sound of the word. This name evokes the feeling of touching and experiencing the soft padding of the leather upholstery. It is also the name of a vegetable which comes in a variety of rounded, curvaceous forms, like the chair.



# Squash Collection | Armchair



## Faye Toogood

“I also loved Poltrona Frau’s iconic Vanity Fair from the Thirties in lipstick red. Straight away I knew I wanted to honor these archive colors and respond with a contemporary shape that met their boldness. It feels very refreshing to make a chair in such a strong, saturated shade.”

## Memories of a soft and welcoming past

- The image looks highly innovative compared to the contemporary production of Poltrona Frau. Actually has a solid link with the stylistic evolution of the company of which reinterprets some distinctive elements of the past.
- Like an elegant and generous softness, the roundness of the shapes and a strong materiality of the leather upholstery with craftsmanship details.



# Squash Collection | Armchair



## A dry and sculpted structure, like stones smoothed by water

- The armchair is made of two sides that bend towards the inside of the seat. The sides hold on a cradle which embrace all the padding.
- The structural sides are slightly padded and shaped along the perimeter with an elliptical section enriched by a double stitching that runs all around the edge.
- Visually bent towards the inside of the seat, the sides give a visual effect of crushing the plump cushion that looks squeezed inside the structure.



# Squash Collection | Armchair & Ottoman – Upholsteries and Finishes



## UPHOLSTERY: STRUCTURE / CUSHION \*

- ColorSphere® (SC) (2-tones allowed\*\*)
- Nest (2-tones allowed\*\*)
- Soul
- Velvety
- ColorSphere® (SC) / Fabric A
- ColorSphere® (SC) / Fabric B
- ColorSphere® (SC) / Fabric C
- ColorSphere® (SC) / C.O.M.
- Nest / Fabric A
- Nest / Fabric B
- Nest / Fabric C
- Nest / C.O.M.
- Soul / Fabric A
- Soul / Fabric B
- Soul / Fabric C
- Soul / C.O.M.



→ The structure upholstery is enriched on the edge with double stitching

→ Faye Toogood is inspired by ColorSphere to suggest four tonal color combinations that best represent the contamination between the artist's contemporary vision and the world of Poltrona Frau.

### CREAM

Structure: SC 33  
Cushion: SC 51



### SAGE

Structure: SC 176  
Cushion: SC 173



### BLUE

Structure: SC 276  
Cushion: SC 254



### RED

Structure: SC 92  
Cushion: SC 128



## NOTES

\* Removable upholstery only for the seat and back cushions

\*\* The two-tone option provides a 5% increase over the price of the leather category

# Squash Collection | Low Table

CREAM (SC 33)



SAGE (SC 173)



BLUE (SC 254)



BROWN (SC 68)



## A stack of rigid and soft elements

- The Squash furniture collection is completed with a small low table that reinterprets the concept of the armchair characterized by the contrast between a sculpted structure and a soft cushion.
- It consists of two mirror polished blocks glossy that squeezing a cushion ColorSphere leather upholstered in a matching color tone.
- It is available in 4 colors matching the color-mood of the armchair: Cream, Sage, Blue and Brown.
- **OPTIONAL:** the low table can be enriched on the top by a ColorSphere leather pad in a matching color tone with the cushion.

# Squash Collection | Technical Features



## ARMCHAIR



84 / 33"  
54 / 21"  
45 / 17"



60 / 23"  
92 / 36"



49 / 19"  
103 / 40"

## OTTOMAN



40,5 / 16"



63 / 24"



72 / 28"

## LOW TABLE



46 / 18"



54 / 21"



54 / 21"

**ARMCHAIR SEAT AND BACKREST:** polimex® and poplar plywood structure

**ARMCHAIR SEAT AND ARMRESTS CUSHION:** made of polyurethane foam and polyester wadding. Polyurethane cushion is made by gluing of different foam densities, for greater comfort.

**ARMCHAIR BASE AND LEGS :** made of birch plywood and black painted steel cross. The legs of the base are covered in leather with light padding in polyurethane foam.

**POUF BASE:** made of MDF (legs) and birch plywood with light polyurethane foam padding.

**POUF CUSHION:** made of polyurethane foam and polyester wadding.

**SLIDES:** made of black nylon.

**UPPER AND LOWER BLOCKS:** made of glossy lacquered MDF.

**CENTRAL CUSHION:** structure made of MDF with polyurethane foam and wadding polyester.

**BOTTOM:** made of matt black painted MDF and protected by a felt pad.



# Parka

Design: Draga & Aurel



# Parka | Design by Draga & Aurel



Visionaire



Rossana Orlandi



Nilufar



Baxter

Galotti & Radice



## A continuous challenge between art and design

Established in 2007 by Draga Obradovic and Aurel K. Basedow, Draga & Aurel is a multidisciplinary studio and workshop for art, collectible design, and furnishing items based in Como. Armed with a diversified background in art, fashion, and craftsmanship, Draga & Aurel are widely known for combining original methods with an artistic approach to materials and composition. Awarded AD100 in 2023 they have several partnerships with furniture companies like Baxter, Galotti e Radice, Visionaire Wall&Deco and with most influent international galleries like Rossana Orlandi, Nilufar and Todd Merrill.

# Parka | Concept



## Draga & Aurel

«Draga & Aurel love fashion, vintage taste, enveloping lines. Passions that are fully expressed in their first project for Poltrona Frau, Parka, a modular seating system that pays homage to a great Streetwear classic clothe of the 90s, which the grunge culture in America and the “paninari” in Italy appointed as a symbol of a generation. Like the iconic coat, Parka is a sofa that is as gritty as it is welcoming, as sober as it is sophisticated, extremely versatile: a passe-partout that adapts to every look and to environments with strong personalities. »





## A strong personality

- Parka shows a new concept of convivial sofa, for conversation, never explored until now by Poltrona Frau.
- Through a volumetric, fully, and sculptural design is a sofa with a low seat that is inspired by the 70's style and invites you to sink into its curves.
- We can find clear vintage design references reinterpreted in a contemporary style, to achieve an indisputable and luxurious elegance.
- Strong and distinctive personality coming from a skilled design of shapes, proportions and upholstery details, without using of other decorative or structural elements.



## Few elements for infinite solutions

- The new seating system has an extremely simplified modularity thanks to only 6 sectional armchairs, of which 2 without armrests and 4 end armchairs with right or left armrest.
- The armchairs have the particularity of a trapezoid shape in plan view and with an angle of  $18^\circ$  which can be concave or convex. This feature allow the design of infinite straight or curved solutions.
- The curved lines design all the surfaces of the product and are very evident on the external vertical surface, where the padded part of the seat and backrest comes over the structure.





## Soft and welcoming padding

- Two types of armrests available, one standard with a small size and the second with a Maxi size which thanks to its boldness allows the design of an additional and informal seat extension on the side of the sectional armchair.
- The seat and back padding is quite full, soft and shows an upholstery full of natural ripples contained by a more organic and sculpted lower upholstered structure.
- The difference between the two upholstered areas - the one inside the seating area and the outside of the structure - creates a distinctive aesthetical feature. The product has a strong versatility in combinations of all leather upholsteries or combining the leather structure and the fabric cushions with hundreds color matching tones as in the Poltrona Frau's offering.





## Dynamic and reconfigurable, it adapts to every need

- The new seating system is very flexible, dynamic and reconfigurable over time. Parka matches perfectly in the most diverse interiors, from the largest and most decorative spaces to the most minimal and sophisticated interiors with an extreme adaptability on sizes
- Sectional armchairs are connected to each other through an easily removable system that allows for reconfigurability over time, adapting to the evolution of living needs and spaces.

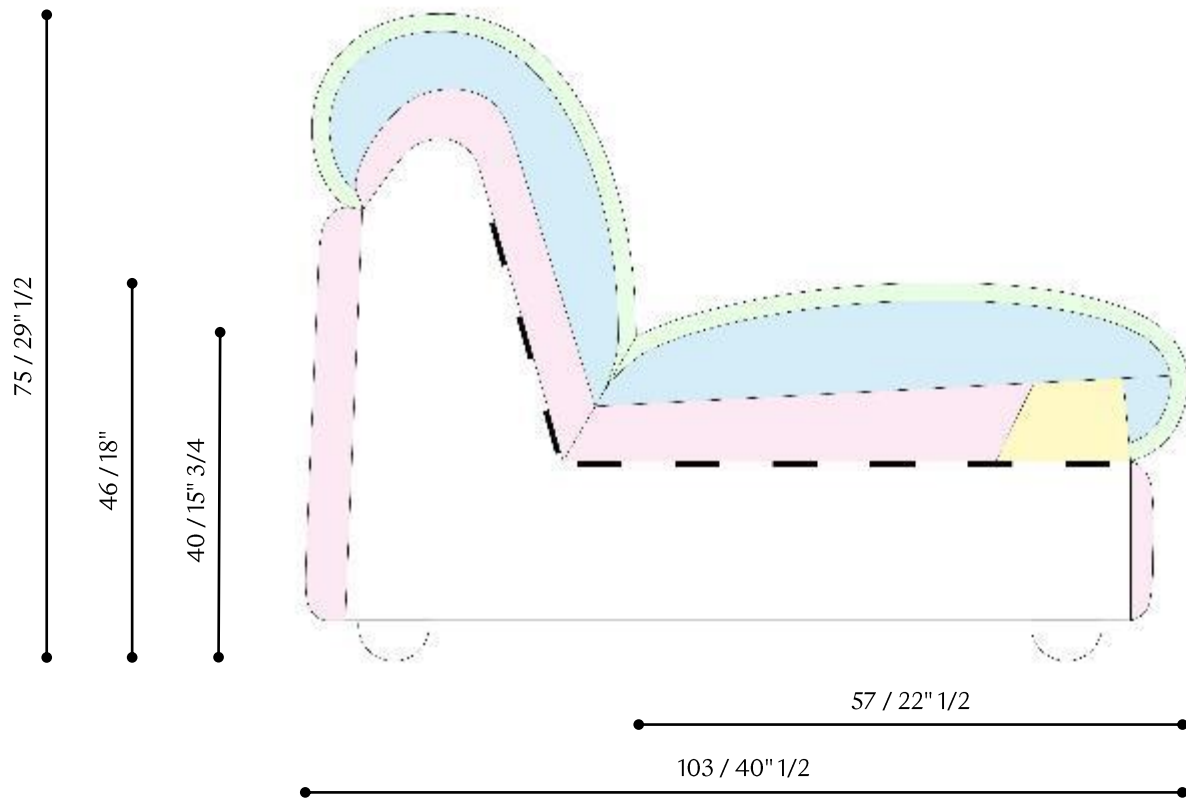

## Comfort

- Well sized seat depth to avoid the use of an added on back cushion, like it is for the Happy Jack sofa.
- The inclined seat welcomes the seated person who finds a comfortable wrap up till the area under the shoulders, despite the reduced overall height.
- Not only for the seat, but elastic belts are also applied on the padding of the back to ensure a more enveloping comfort.
- Low density padding with new high-performance polyurethane combined with a high thickness polyester fiber for a softness similar to feathers.



POLYURETHANE  
LOW DENSITY



POLYURETHANE  
MEDIUM DENSITY



POLYURETHANE  
HIGH DENSITY



POLYESTER  
FIBER



STRUCTURE



ELASTIC  
BELTS

# Parka | Sizes



Convex sectional armchair  
without armrest

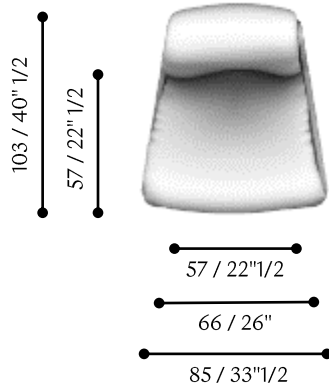

Convex sectional armchair  
with armrest Rt\* - Lt

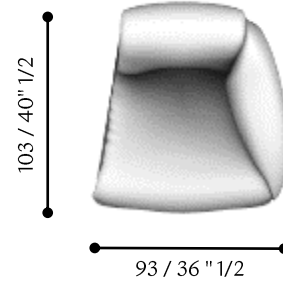

Convex sectional armchair  
with Maxi armrest Rt\* - Lt

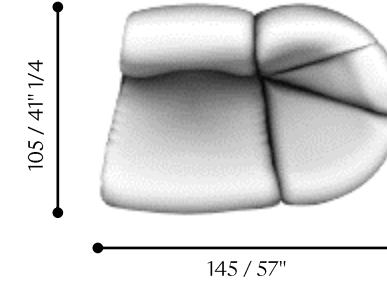

Concave sectional armchair  
without armrest

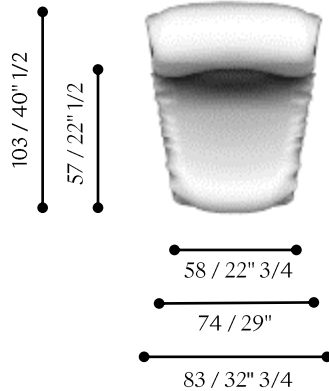

Concave sectional armchair  
with armrest Rt\* - Lt

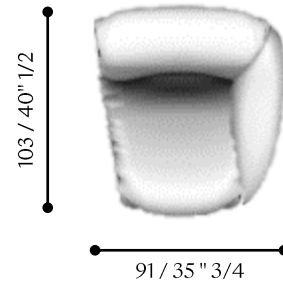

Concave sectional armchair  
with Maxi armrest Rt\* - Lt

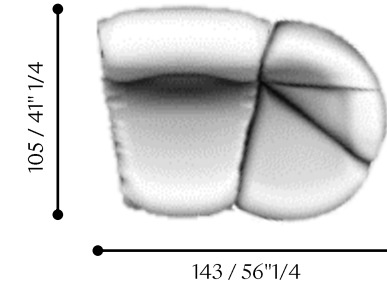

## NOTE

\* Right armrest (Rt) shown in the plan drawing. Left armrest (Lt) It is symmetrical opposite

# Parka | Layout Examples



## LAYOUT EXAMPLE NO. 1

- **Concave** sectional armchair with Maxi armrest Lt
- **Concave** sectional armchair with Maxi armrest Rt

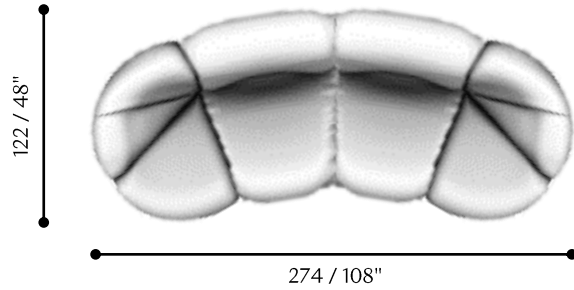

## LAYOUT EXAMPLE NO. 2

- **Convex** sectional armchair with Maxi armrest Lt
- **Concave** sectional armchair without armrest
- **Convex** sectional armchair with Maxi armrest Rt

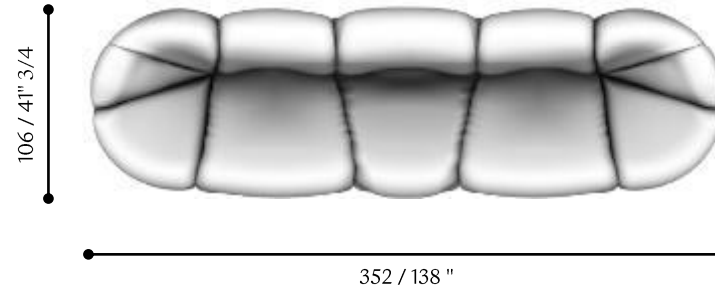

## LAYOUT EXAMPLE NO. 3

- **Convex** sectional armchair with Maxi armrest Lt
- **Concave** sectional armchair without armrest (2 pcs)
- **Concave** sectional armchair with Maxi armrest Rt\*-Lt

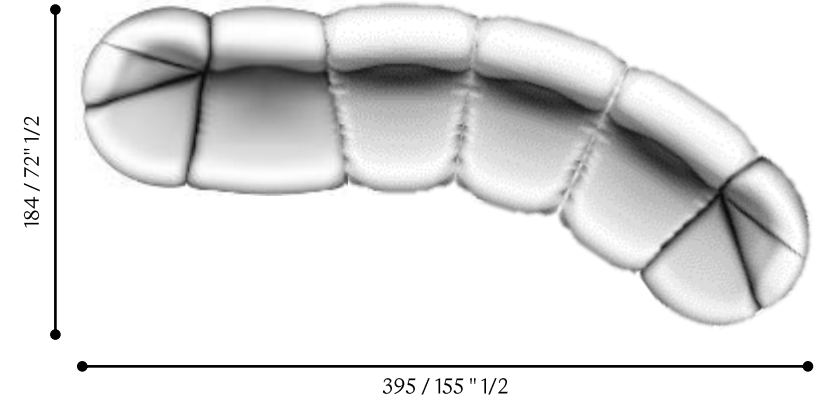

## LAYOUT EXAMPLE NO. 4

- **Convex** sectional armchair with armrest Lt
- **Convex** sectional armchair with armrest Rt

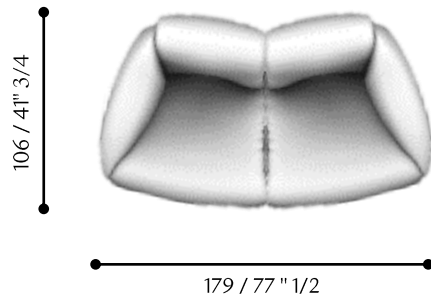

## LAYOUT EXAMPLE NO. 5

- **Convex** sectional armchair with armrest Lt
- **Concave** sectional armchair without armrest
- **Convex** sectional armchair with armrest Rt

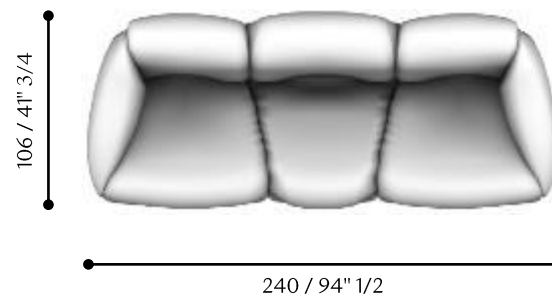

## LAYOUT EXAMPLE NO. 6

- **Convex** sectional armchair with armrest Lt
- **Concave** sectional armchair without armrest (3 pcs)
- **Convex** sectional armchair with armrest Rt

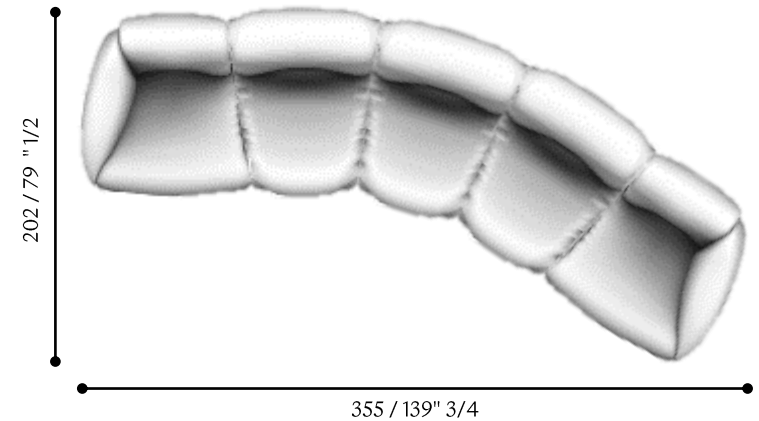



# Parka | Upholsteries and Finishes



## UPHOLSTERY: STRUCTURE / CUSHION \*

- ColorSphere® (SC) (2-tones allowed\*\*)
- Nest (2-tones allowed\*\*)
- Soul
- Velvety
- ColorSphere® (SC) / Fabric A
- ColorSphere® (SC) / Fabric B
- ColorSphere® (SC) / Fabric C
- ColorSphere® (SC) / C.O.M.
- Nest / Fabric A
- Nest / Fabric B
- Nest / Fabric C
- Nest / C.O.M.
- Soul / Fabric A
- Soul / Fabric B
- Soul / Fabric C
- Soul / C.O.M.



### LAYOUT EXAMPLE NO. 5

- **Convex** sectional armchair with Maxi armrest Lt
- **Concave** sectional armchair without armrest
- **Convex** sectional armchair with Maxi armrest Rt

Upholstery: Pelle Frau SC 233 + Suri col. Azul



### LAYOUT EXAMPLE NO. 2

- **Convex** sectional armchair with Maxi armrest Lt
- **Concave** sectional armchair without armrest
- **Convex** sectional armchair with Maxi armrest Rt

Upholstery: Pelle Frau Nest col. Pietra di Sole

FEET

Birch black coated

## NOTES

\* Removable upholstery only for the seat and back cushions

\*\* The two-tone option provides a 5% increase over the price of the leather category

---

Imagine **Versatility**

---

# 2024 Imagine Collection | Imagine Versatility



## # Range Extensions

- Happy Jack
- Bretagne Gran Comfort
- Pillow Cinema
- Brera
- Grant
- Bay Pouf
- Nice

## # Duo Dining Collection

- Duo Chair
- Duo Table
- Duo Cabinet
- Duo Bench

## # Home-office Collection

- Archibald Large Chair
- Archibald Task Chair
- Peek-a-Book Large Desk

## # Bedroom Collection

- Archibald Bed
- Stock'n Roll
- Nymph

## # Upholsteries and Finishings

- Pelle Frau Nest
- Pelle Frau Motif Knits
- Fabric Collection 2024
- Frassino Naturale



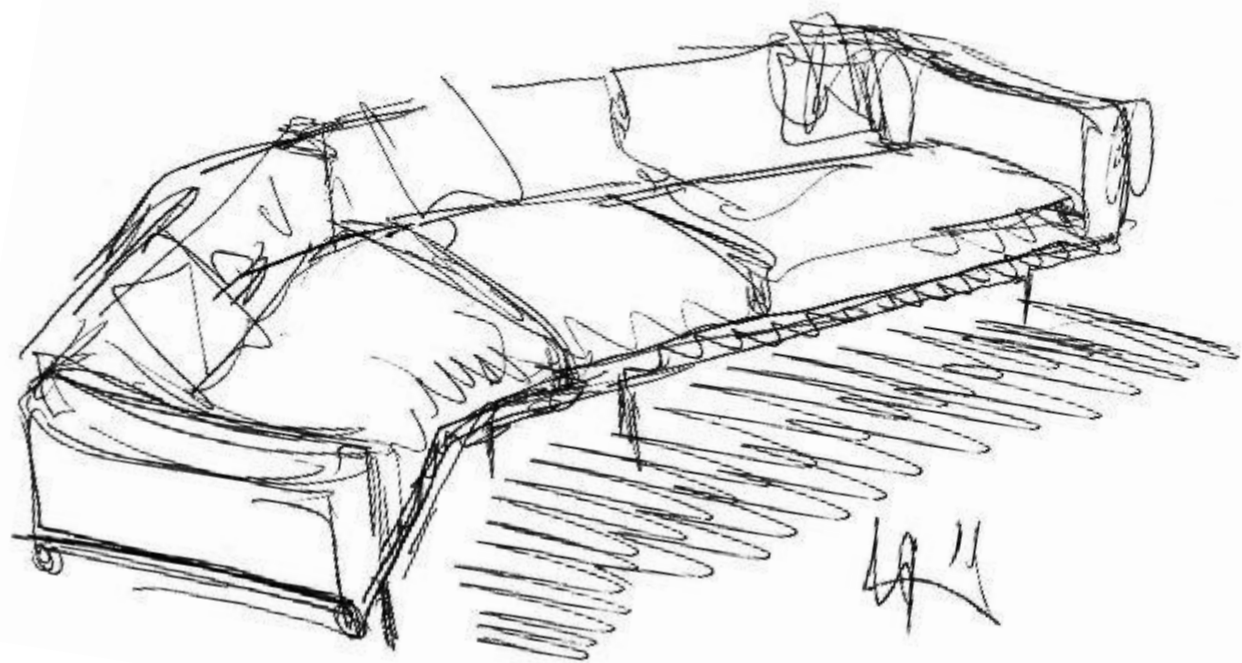

# Happy Jack

Design: Ludovica+Roberto Palomba

RANGE EXTENSION

# Range Extension | Happy Jack



## New Large 3-Seater Sofa

- Range extension of the collection with a large 3-seater sofa available in the single or the sectional solution.
- New sofa is designed from the 86 cm wide seat cushion already used for the large 2-seater sofa



PHOTO:  
Happy Jack: Large 3-seater sofa  
Upholstery: SC 136 / Ziggy col. Sunflower  
Feet: Ruthenium

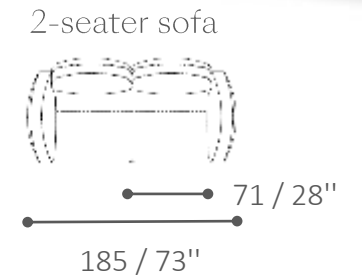
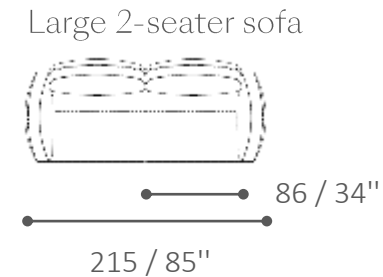
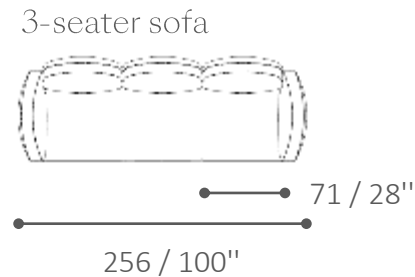
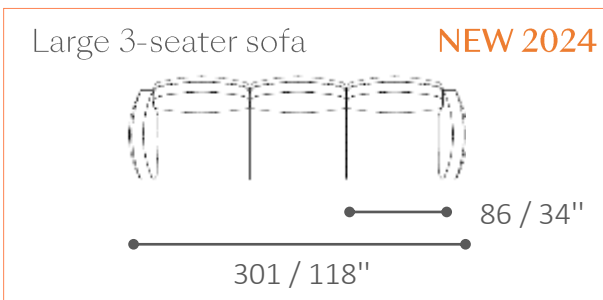

# Range Extension | Happy Jack



Large 2-Seater Sofa + Pouf Standard  
2022



Large 3-Seater Sofa + Pouf Large H45  
NEW 2024



## New Pouf H45

- New version of the pouf raised from the ground using the same frame and feet components as the sofa.
- Cushion available with two widths, standard or large, which copy the size of the sofa cushions.

Pouf H45  
NEW 2024

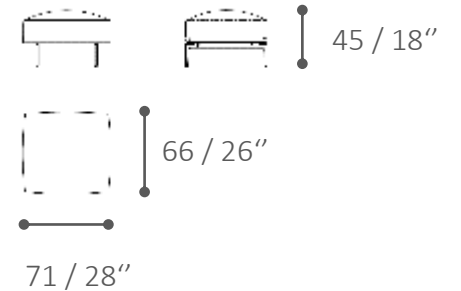

Pouf Large H45  
NEW 2024

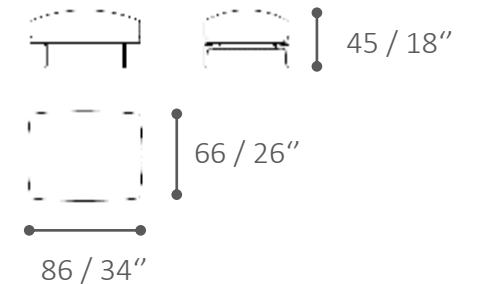

## New Sectional 45° Corner Sofa

- New module for more dynamic compositions.
- The back cushion of the corner module has been increased to 100 cm length, allowing greater comfort and enough size for two people seating in.
- The seat cushion is made with a full cover which makes it easily combinable with all sizes of end sofas.
- The corner module is available in both versions with and without armrest.



**PHOTO:**

Happy Jack: Sectional 45° Corner Sofa with armrest Rt  
Upholstery: Alchemy / Mollis  
Feet: Ruthenium

Sectional 45° Corner Sofa  
without armrest

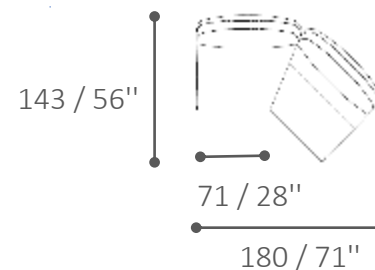

Sectional 45° Corner Sofa  
with armrest Rt-Lt

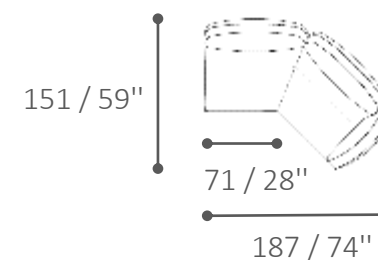



# Range Extension | Happy Jack



**PHOTO:**  
Happy Jack:  
n.1 Sectional Chaise Longue Recliner with armrest Rt  
n.1 Sectional Large 2-seater Sofa with armrest Lt  
Upholstery: SC 65 Vachette  
Feet: Ruthenium

## New Chaise Longue Recliner

- The reclining mechanism will be available on three different modules: a Chaise Longue with or without armrest and a new Bench version.
- The new recliner modules can live as stand alone or linked with other sectional sofas to design larger compositions.
- The stitchings up-on the seat cushion better highlights the seating area to identify the correct position in which you have to lie down and allow the correct movement of the mechanism
- The user can select the inclination of the backrest and the legs through acting on a wireless remote control.

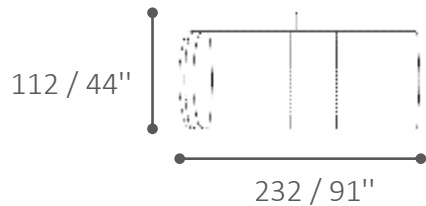

Sectional Chaise Longue Recliner  
with armrest Rt-Lt

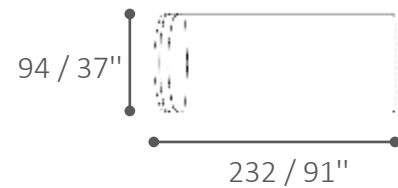

Sectional Chaise Longue Recliner  
without armrest

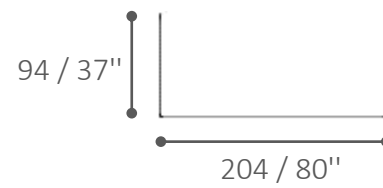

Bench Recliner



## Chaise Longue Recliner with Armrest

- The chaise-longue is available with a leather armrest having a brand-new design more functional to the new product.
- The armrest has a shelf solution designs with an upside-down L-shaped geometry. This feature lightens the length of the 120 cm long armrest that extends from the backrest to the middle of the seat cushion.
- The armrest is equipped with a smart pocket to keep the remote control.

## Reclining Mechanism

- Electric powered reclining mechanism is installed inside the seat cushion without leaving any components visible, even when the cushion is fully raised.
- The mechanism has a double lever that allows simultaneous movement with different degrees of inclination of both the back and the legs.
- Main power supply is a mandatory accessory

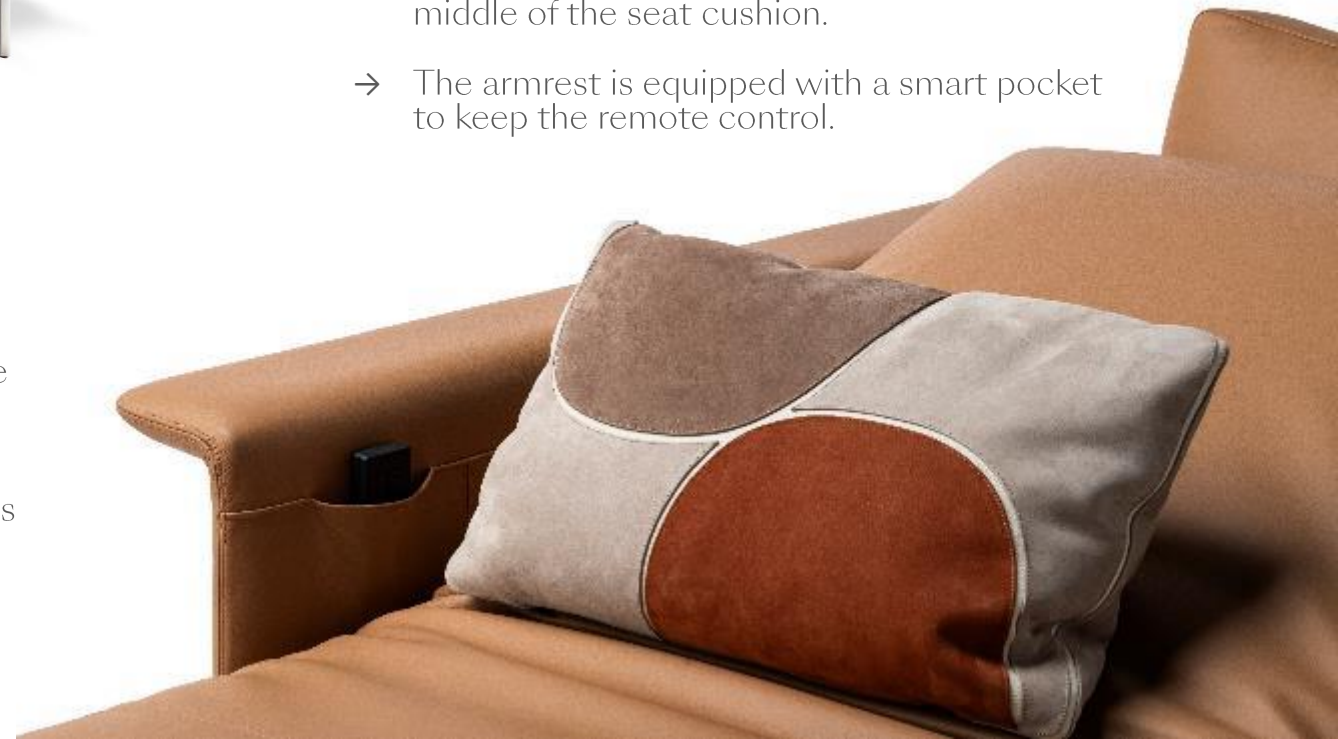

# Range Extension | Happy Jack – Sizes



Large 3-Seater Sofa



Corner Large 3-Seater Sofa Rt-Lt

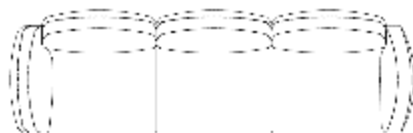

Pouf  
h45



Sectional Chaise Longue Recliner  
with armrest Rt-Lt



Sectional Large 3-Seater Sofa  
without armrest



Corner Large 3-Seater Sofa Rt-Lt  
without armrest

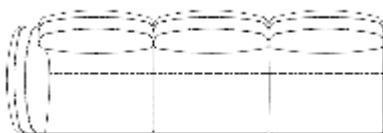

Pouf Large  
h45



Sectional Chaise Longue Recliner  
without armrest



Sectional 45° Corner Sofa  
with armrest Rt-Lt

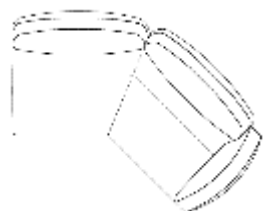

Sectional 45° Corner Sofa  
without armrest

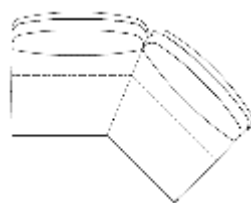

Bench Recliner



A close-up photograph of a chair's backrest and seat. The backrest is covered in a light-colored, textured fabric, while the seat is upholstered in a brown, woven leather-like material with a distinct diamond-shaped pattern.

# Bretagne Gran Comfort

Design: Poltrona Frau Style & Design Centre

RANGE EXTENSION



# Range Extension | Bretagne Gran Comfort



BRETAGNE | 3-seater sofa  
2010

## New Comfort

- 14 years after its launch the sofa updates with a new solution which has higher and more enveloping comfort. The external structure and base remain the same.
- The new cushion version is available only with single sofas, 2-seater, 2-seater large, 3-seater and the pouf.



BRETAGNE GRAN COMFORT | 2-seater large sofa  
NEW 2024

# Range Extension | Bretagne Gran Comfort



- The **back cushions have been increased in size and padding** to reach a more consistent lumbar support and a comfortable headrest.
- The backrest remains in feather but with greater density to welcome and support.



- The **feet doesn't change** in finish and height to lift the sofa from the ground and to give a lighter feeling.

- **Seat cushions are now more structured** and with perfect visible stitching which increases the elegance of the upholstery keeping the shape and the structure during the years.
- This version, like the Happy Jack, **uses differentiated density foams and polyester wadding** for a better formal design and for the recovery of shape.



# Range Extension | Bretagne Gran Comfort - Pelle Frau Motif Knits



→ The **branding for the Pelle Frau Motif Knits upholstery** is hot-embossed on a pelle Frau Velvety leather color matching.

→ The **upholsteries** have been expanded thanks to the **introduction of Pelle Frau Motif Knits leather** for the external upholstery

Pelle Frau Motif Knits upholstery available in 4 colors:



DEEP  
LAVENDER



SESAME



PAPRIKA



GREY SALT





# Range Extension | Bretagne Gran Comfort – Upholsteries and Finishes



## UPHOLSTERY: STRUCTURE / CUSHIONS \*

- ColorSphere® (SC) (2-tones allowed\*\*)
- Nest (2-tones allowed\*\*)
- Soul
- Velvety
- ColorSphere® (SC) / Fabric A
- ColorSphere® (SC) / Fabric B
- ColorSphere® (SC) / Fabric C
- ColorSphere® (SC) / C.O.M.
- Nest / Fabric A
- Nest / Fabric B
- Nest / Fabric C
- Nest / C.O.M.
- Soul / Fabric A
- Soul / Fabric B
- Soul / Fabric C
- Soul / C.O.M.
- Pelle Frau Motif Knits / ColorSphere (SC)\*\*\*
- Pelle Frau Motif Knits / Nest\*\*\*
- Pelle Frau Motif Knits / Velvety\*\*\*
- Pelle Frau Motif Knits / Fabric A \*\*\*
- Pelle Frau Motif Knits / Fabric B \*\*\*
- Pelle Frau Motif Knits / Fabric C \*\*\*
- Pelle Frau Motif Knits / Fabric C.O.M. \*\*\*



**PHOTO:**  
BRETAGNE GRAN COMFORT LARGE 2-SEATER SOFA  
External Upholstery: Motif Knits Sesame  
Internal Upholstery: Kalahari Greige

## FEET

- Aluminium in a gunmetal grey finish

## NOTE

- \* Removable upholstery only for the seat and back cushions in leather and for all the items fabric upholstered
- \*\* The two-tone option provides a 5% increase over the price of the leather category
- \*\*\* To avoid color passing it is recommended to combine Pelle Frau Motif Knits with Pelle Frau or Fabric upholstery in the best color matching



# Pillow Cinema

Design: Poltrona Frau Style & Design Centre

RANGE EXTENSION



# Range Extension | Pillow Cinema



## A new cinema experience from home

- Pillow Cinema is contemporary reclining armchair designed to furnish private cinemas for homes, yachts and luxury hotels.
- A soft and enveloping upholstery which is typical for the armchairs and sofas of Poltrona Frau, characterizes the whole central part of the seat that goes from the footrest to the headrest.





PILLOW  
2011



PILLOW CINEMA  
NEW 2024

## The evolution of the collection

- The distinctive design of the Pillow armchair which has been part of Poltrona Frau's offer since 2011, fits perfectly to develop a new version from Home Cinema with the armrests padded up to the ground.
- The characteristic cushion design of the backrest draws the whole seat from the headrest to the footrest. This feature lightens the padding to fit inside one of the best reclining mechanisms on the market, extremely resistant and durable.
- The thick and padded armrests ensure solid support on the ground and allow extreme versatility to fit optional accessories and customizations in shape and upholstery.

# Range Extension | Pillow Cinema – Upholsteries and Finishes



## UPHOLSTERY\*

- ColorSphere® (SC)
- Nest
- Soul
- Velvety
- Fabric A
- Fabric B
- Fabric C
- C.O.M.

## STANDARD EQUIPMENT

Brushed aluminum control panel on the inside of the armrest with three buttons for independent movement of the headrest, the backrest and the footrest.

A fourth button allows the return of the three parts to the starting position.



## OPTIONAL EQUIPMENT

The armchair can be equipped with two electronic devices to be installed on the armrest: a cooling/heating drink holder with wireless charging, and a flexible arm lamp with USB-A charging station.

In addition to these you can also choose to have a removable top armrest tray made of Saddle Extra leather.



## POWER SUPPLY

The armchair is available with electric power connection or rechargeable battery. This second option does not include the installation of electric optional equipments..

## NOTE

\* Upholstery is not removable.

# Range extension | Pillow Cinema - Sizes



- The armchair can be installed on the ground individually or in line, with an extreme modularity that allows the creation of different layouts.
- The seat can be single spaced by a shared armrest, or double in the configuration called «Love Seat» in which each sitting however keeps the independent movement of its parts.

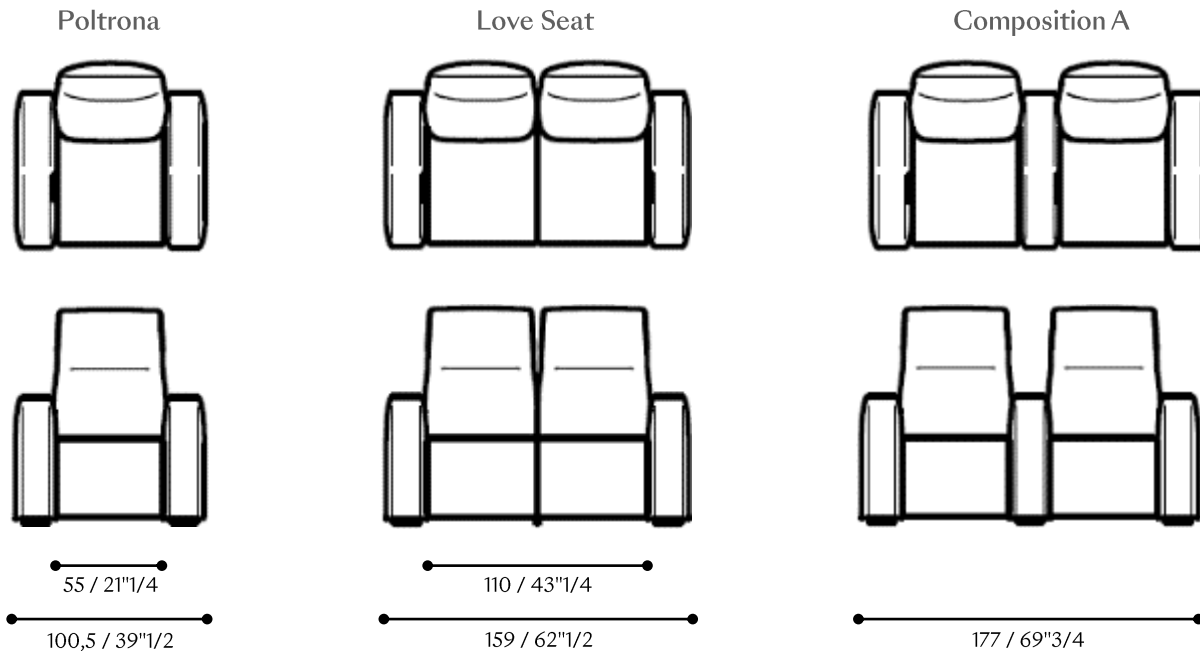
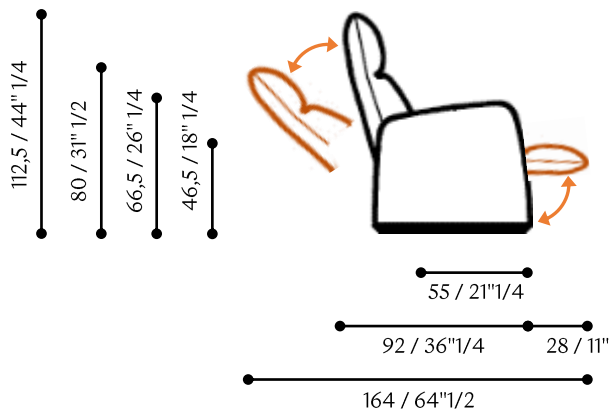

Armchair



Love Seat



Composition A



Composition B

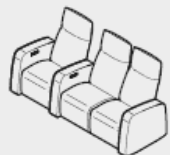

Composition C

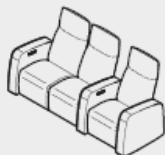

Composition D

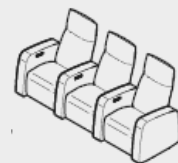

Composition E

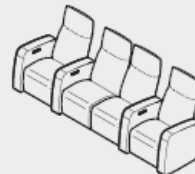

Composition F

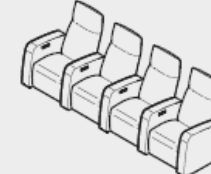



# Brera

Pelle Frau ColorSphere

Design: Guglielmo Ulrich

# Brera

90th Limited Edition

Design: Guglielmo Ulrich  
Style: Simona Cremascoli

RANGE EXTENSION



# Range Extension | Brera - Pelle Frau ColorSphere



## STRUCTURE



Ash in a  
wenge stain  
(32)



Ash in a  
moka stain  
(61)

## New Leather Version

- New ColorSphere leather upholstery available in 73 colours.
- The leather belts are finished with a live cut edge and tone-on-tone colour.
- The side decorative tone on tone stitching by 3 mm from the edge replaces the marking lines present in the saddle version.

SC 31 Quarzo Fumè

Tone on tone stitching

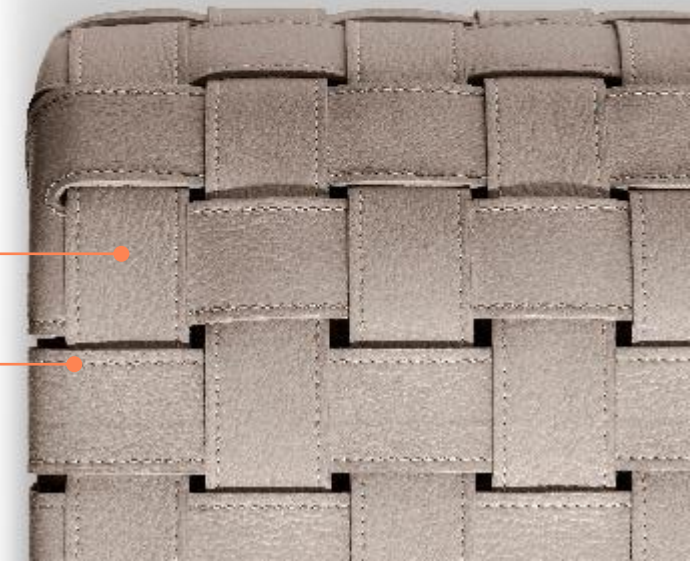

# Range Extension | Brera – 90th Limited Edition

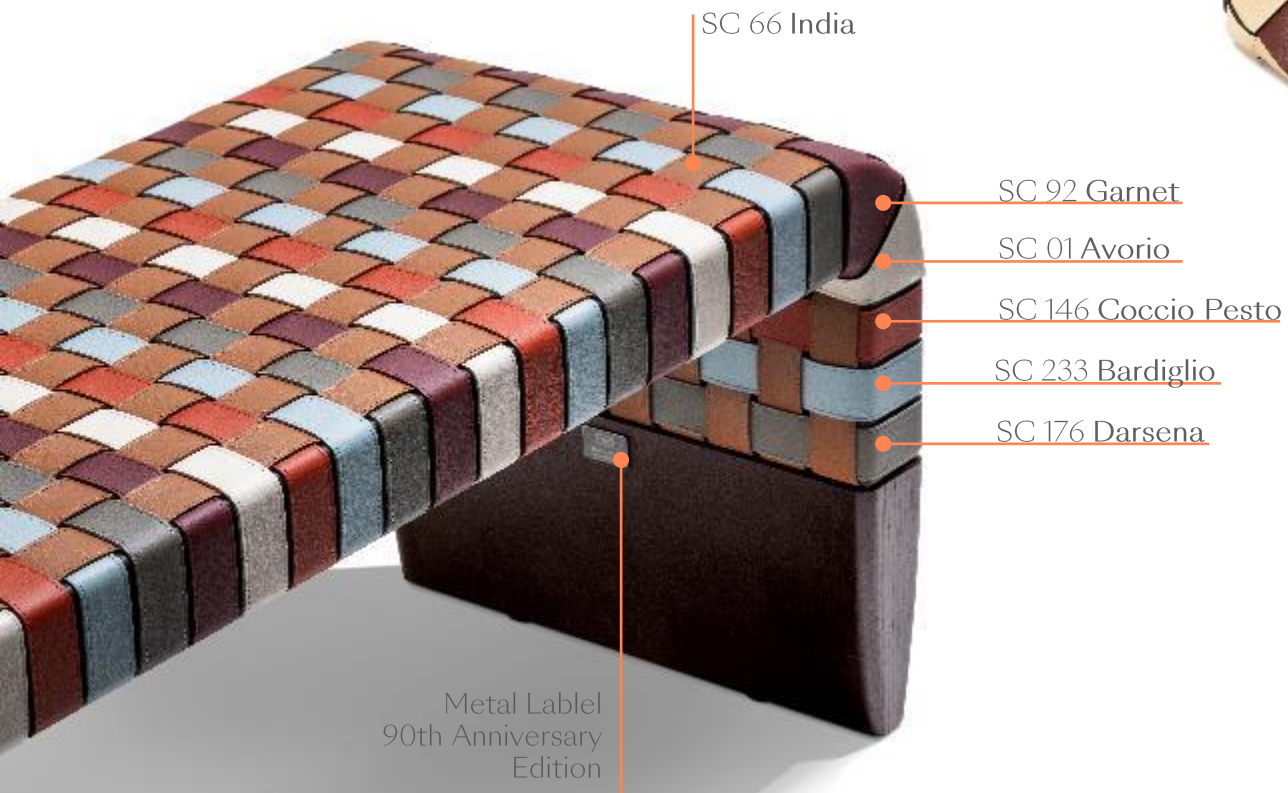

## Fashion world inspiration

- Multicolor version with predefined color sequence for the 90th anniversary, inspired by the world of fashion, designed by Guglielmo Ulrich in 1934 and interpreted by Simona Cremascoli.
- The belts follow the same technical specifications as the SC version, and the base is enriched inside with a decorative metal label in Ruthenium finish.
- Version available for order until 31th December '24





# Grant

Design: Tristan Auer

RANGE EXTENSION

# Range Extension | Grant - Pelle Frau Motif Knits



GRANT DE LUXE 90x64  
2020



GRANT DE LUXE Ø46  
2020

→ **NOTA: Pelle Frau Motif Knits** upholstery only available on these ottoman sizes

## Main Features

- The new version joins the one with **woven leather bands**, maintaining the aesthetic effect and preciousness that distinguishes the collection.
- The innovative hot-embossing technique on Pelle Frau Velvety allows **the charm and three-dimensionality of the weave to be preserved** and respect the richness and soul of Velvety leather.
- New upholstery is available in **Pelle Frau Motif Knits color matching Pelle Frau Velvety for the top.**



Pelle Frau Velvety

Pelle Frau Motif Knits

**PHOTO:**  
GRANT Ø46x46h  
External Upholstery: Motif Knits Grey Salt  
Seat Upholstery: Velvety Grey Salt

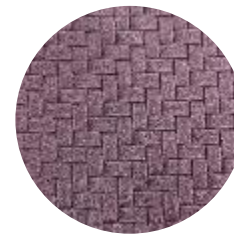

DEEP  
LAVENDER



SESAME

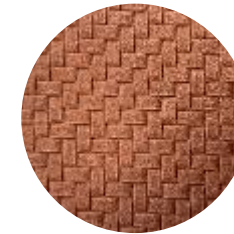

PAPRIKA



GREY SALT

GRANT DE LUXE Ø46  
PELLE FRAU MOTIF KNITS  
**NEW 2024**





# Bay Pouf

Design: Foster + Partners

RANGE EXTENSION



# Range Extension | Bay Pouf



→ Layout example Bay Lounge + Bay Pouf

Sizes:  
 Ø 39 / 15"1/2  
 H 45 / 18"

LEATHER HANDLE



## UPHOLSTERY\*

- ColorSphere® (SC)
- Nest
- Soul
- Fabric A\*\*
- Fabric B\*\*
- Fabric C\*\*
- C.O.M.\*\*

## Main features

- The Bay System collection is enriched with a lightweight and versatile pouf that is suitable to complete the functionality of environments.
- Can be used individually for informal sessions or in groups to create conversation areas in an open-plan office or even in a public space.
- Clean and unobtrusive geometric shape, lightened by the chamfer bottom edge, easily matches both the Bay System and other furniture for public spaces, offices and residential spaces as well
- Elegant workmanship details typical of Poltrona Frau are visible in the leather handle enriched with precious tone on tone stitching and fixed on a polished stainless-steel button.

## NOTES

\* Upholstery is not removable

\*\* Choosing the fabric upholstery the handle is available in Pelle Frau ColorSphere (SC) in the following colors only : SC21 - SC28 - SC68.



# Nice

Design: Gam Fratesi

RANGE EXTENSION

# Range Extension | Nice – Wood Base



NICE – METAL BASE  
2022



NICE – WOOD BASE  
NEW 2024

## Main Features

- The new base joins the previous cast aluminum version launched in 2022.
- With the new legs in wood the chair acquires a completely new image, now can better match with Poltrona Frau wooden tables
- Legs are in solid ash-wood available in three finishes:



Natural Ash



Ash in a  
moka stain  
(61)



Ash in a  
wenge stain  
(32)

# Range Extension | Nice – Wood Base



- The **backrest** angle has been changed, it is now **less inclined** for a more comfortable seat
- The **new wooden base** has been designed and engineered **25 mm lower** than the cast aluminum version.



- The **precious workmanship of the solid wood** emphasizes the clear and sculptural surfaces of the elegant base



# Range Extension | Nice - Upholsteries and Finishes

## UPHOLSTERY\*

- ColorSphere® (SC) (2-tones allowed\*\*)
- Nest (2-tones allowed\*\*)
- Soul
- Fabric A
- Fabric B
- Fabric C
- C.O.M.
- Motif Weavers / ColorSphere® (SC)
- Saddle Extra / ColorSphere® (SC)
- Saddle Extra / Nest
- Saddle Extra / Soul
- Saddle Extra / Fabric A
- Saddle Extra / Fabric B
- Saddle Extra / Fabric C
- Saddle Extra / C.O.M.

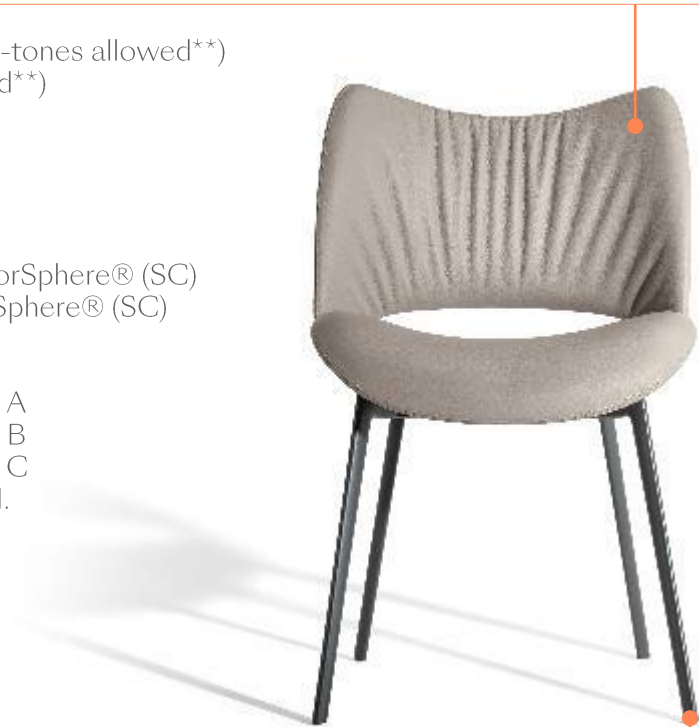

**PHOTO:**  
Upholstery: SC26 Topo  
Base: Burnished painted aluminium

83 / 32"3/4



**PHOTO:**  
Upholstery: Mollis Milk  
Base: Ash in a moka stain

80,5 / 31"3/4

## BASE

- Burnished painted aluminium
- Titanium painted aluminium
- Natural Ash
- Ash in a moka stain (61)
- Ash in a wenge stain (32)

**NEW 2024**

## NOTES

\* Upholstery is not removable

\*\* The two-tone option provides a 5% increase over the price of the leather category





CECCOTTICOLLEZIONI



# Duo Collection

Design: Roberto Lazzeroni

## RANGE EXTENSION

- **Duo Table** (Ceccotti Collezioni)
- **Duo Chair** (Poltrona Frau)
- **Duo Cabinet** (Ceccotti Collezioni)
- **Duo Bench** (Ceccotti Collezioni)

# Duo Collection | Concept

CECCOTTICOLLEZIONI



## From Living to Dining

Ceccotti Collezioni and Poltrona Frau collaboration began in 2023 with the launch of the DUO collection that continues today with the expansion of the furniture offering

The second chapter of the collection focuses on the dining area with new proposals designed by Roberto Lazzeroni.

# Duo Collection | Overview

CECCOTTICOLLEZIONI



DUO **Sofa**  
(PF)



DUO **Cabinet**  
(CC)



DUO **Low Table**  
(CC)



DUO **Bench**  
(CC)



DUO **Mirror**  
(CC)



DUO **Screen**  
(CC)



DUO **Pedestal Table**  
(CC)



DUO **Lounge**  
(PF)



DUO **Rug**  
(PF)



DUO **Trolley**  
(CC)



DUO **Lamp**  
(CC)



DUO **Floor Mirror**  
(CC)



DUO **Bookcase**  
(CC)



DUO **Console**  
(CC)

NEW 2024



DUO **Chair**  
(PF)



DUO **Table**  
(CC)



DUO **Cabinet**  
(CC)



DUO **Bench**  
(CC)

CECCOTTICOLLEZIONI



# Duo Chair

Design: Roberto Lazzeroni

RANGE EXTENSION



# Range Extension | Duo Chair

CECCOTTICOLLEZIONI



## Main Features

- DUO designs romantic and welcoming environments, suggested by the Fifties mood of an Italy in post-war rebirth and in full intellectual and creative re-born.
- The new chair is available in two versions, with a high backrest and in a version with armrests having also a low back
- Typical details of Poltrona Frau's traditional upholstery technique interpreted in a contemporary key.

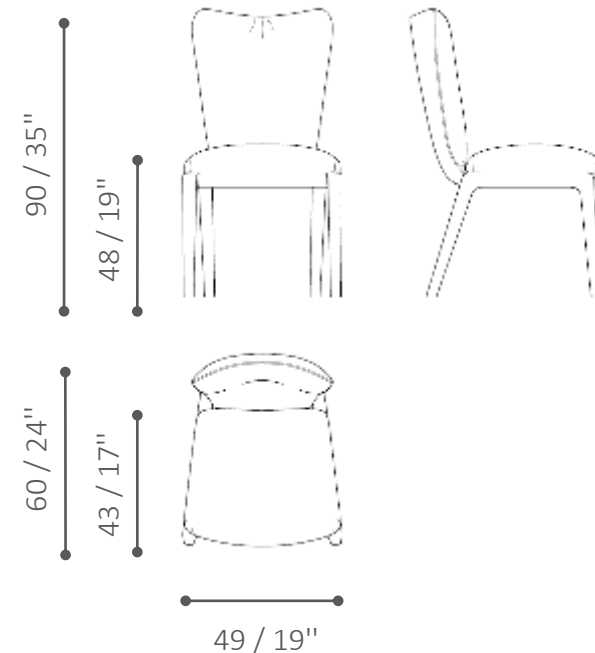



**PHOTO:**  
Duo Chair  
Upholstery: SC 65 Vachette  
Structure: Ash in a wenge stain (32)

## Duo High Back Chair

- The Duo Chair is characterized by a generous padding and the design signature of the backrest.
- It takes up some typical features of the Duo Lounge, such as the bottom upholstered frame hold-on by the two trestles on each side. On the top we find a padded cushion with a double pence on each upholstery of the corner.



## Duo Armchair Version

- The Duo armchair stands out not only for its rounded armrests but also for its generous padding and its sinuous and enveloping line.
- It takes up the distinctive features of the Duo Lounge, fitting into the collection without being just a banal re-sized version of the Lounge one.

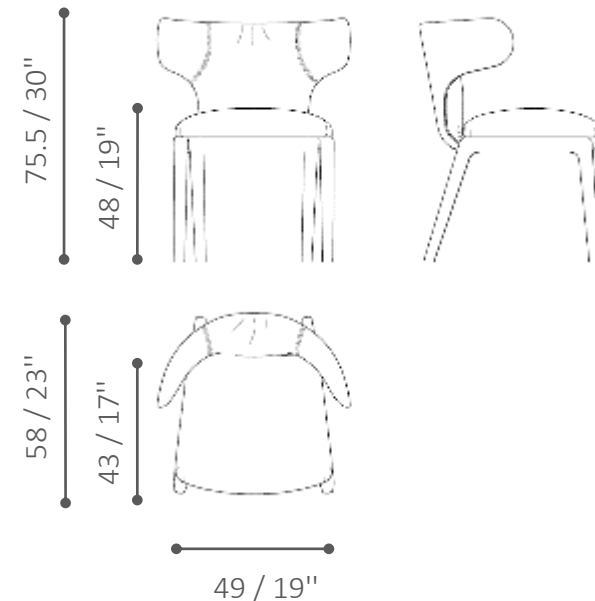

**PHOTO:**  
Duo Armchair  
Upholstery: Wool Satin Light Marengo  
Structure: Ash in a wenge stain (32)

# Range Extension | Duo Chair - Upholsteries and Finishes

CECCOTTICOLLEZIONI



## UPHOLSTERY\*

- ColorSphere® (SC)
- Nest
- Soul
- Fabric A
- Fabric B
- C.O.M.

## BRANDING

→ **Leather version:** hot-stamped logo placed at the bottom center of the back.

→ **Fabric version:** hot-stamped logo on saddle label positioned between the back leg and the backrest.

## STRUCTURE



Ash in a wenge stain  
(32)



Ash in a moka stain  
(61)

## NOTE

\* Upholstery is not removable

\*\* The structure of the chair is made of polyurethane molded foam with metal insert and elastic belts on the seat

CECCOTTICOLLEZIONI



# Duo Table

Design: Roberto Lazzeroni

RANGE EXTENSION

## Main Features

- Duo Table is a table defined by clean-cut and softly curved lines for a minimalist approach to form.
- Precious materials and functional design make the DUO Table perfect for spaces and contexts of various types.



**PHOTO:**  
Duo Table 292  
Top: Calacatta  
Structure: Ash in a wenge stain (32)



## A clean line structure

- The wood base made in solid a Wengé or Moka-stained ash, **recall the design of Duo Low Tables where a trestle hold on the top the marble top.**
- Duo Table is the first example in the Ceccotti Collezioni offering of a **table with a “free” slab marble top** without any perimetral frame.
- The structure hold on the **rectangular top** (250 cm or 292 cm) or **round top** (diameter 150 cm or 180 cm) in Calacatta marble.



**PHOTO:**  
Duo Table D180  
Top: Calacatta  
Structure: Ash in a wenge stain (32)



## STRUCTURE



Ash in a  
wenge stain  
(32)



Ash in a  
moka stain  
(61)

## METAL PARTS

Brushed bronzed brass



## TOP



Semi-brilliant  
Calacatta marble

## Details

- The legs consist in large wood slat with rounded sides. They feature a cut-out in the upper part that serves as a connecting point with the crossbeams.
- Both the head of the crossbar and the anchor point between the legs and the table cross are finished with **brushed bronzed brass connector**.

# Range Extension | Duo Table - Sizes

CECCOTTICOLLEZIONI



DUO Table 250



DUO Table D150



DUO Table 292



DUO Table D180





CECCOTTICOLLEZIONI



# Duo Cabinet

Design: Roberto Lazzeroni

RANGE EXTENSION

# Range Extension | Duo Cabinet



Duo Low Cabinet  
Inlaid Walnut  
2023



Duo Low Cabinet - Inlaid Maple  
**NEW 2024**



Duo High Cabinet - Inlaid Maple  
**NEW 2024**

## New Finishes

Duo Cabinet is now available with a new external veneer finish in light wood in contrast with the Wengé stained ash structures.

The outside of the container is made of veneered poplar plywood panels available in the finishes:



Maple  
**NEW 2024**



Inlaid  
Maple  
**NEW 2024**



Walnut



Inlaid  
Walnut



Ebony





# Duo Bench

Design: Roberto Lazzeroni

RANGE EXTENSION



## Duo Bench 130

A seat that is almost three times wider compared to the previous version and useful for two people sitting on.

The frame maintains the characteristic **slightly curved shape** which is useful for seating comfort.

Duo Bench is a versatile solution, perfect as a decorative element, a seat for positioning alongside a table or for use as a bench at the foot of the bed.

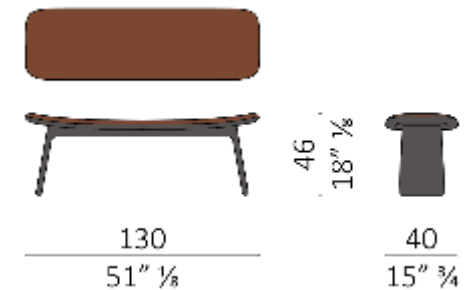

PHOTO:  
Duo Bench 130  
Upholstery: Velvety Paprika  
Structure: Ash in a wenge stain (32)

# Range Extension | Duo Bench 130



Duo Bench  
2023



Duo Bench 130  
**NEW 2024**

## Finishes

→ Structure made of solid ash, available in two finishes:

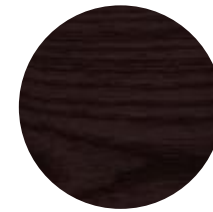

Ash in a  
wenge stain  
(32)



Ash in a  
moka stain  
(61)

## Upholsteries

→ Upholstery selection both available from Ceccotti Collezioni and Poltrona leather or fabrics

- ColorSphere (SC)
- Nest
- Soul
- Natural Leather\*\*
- Velvety
- Fabric\*\*
- Fabric A
- Fabric B
- Fabric C
- C.O.M

### NOTES

\* Upholstery is not removable

\*\* Fabric and Natural Leather refer to the selection of fabrics and leather belonging to Ceccotti Collezioni.

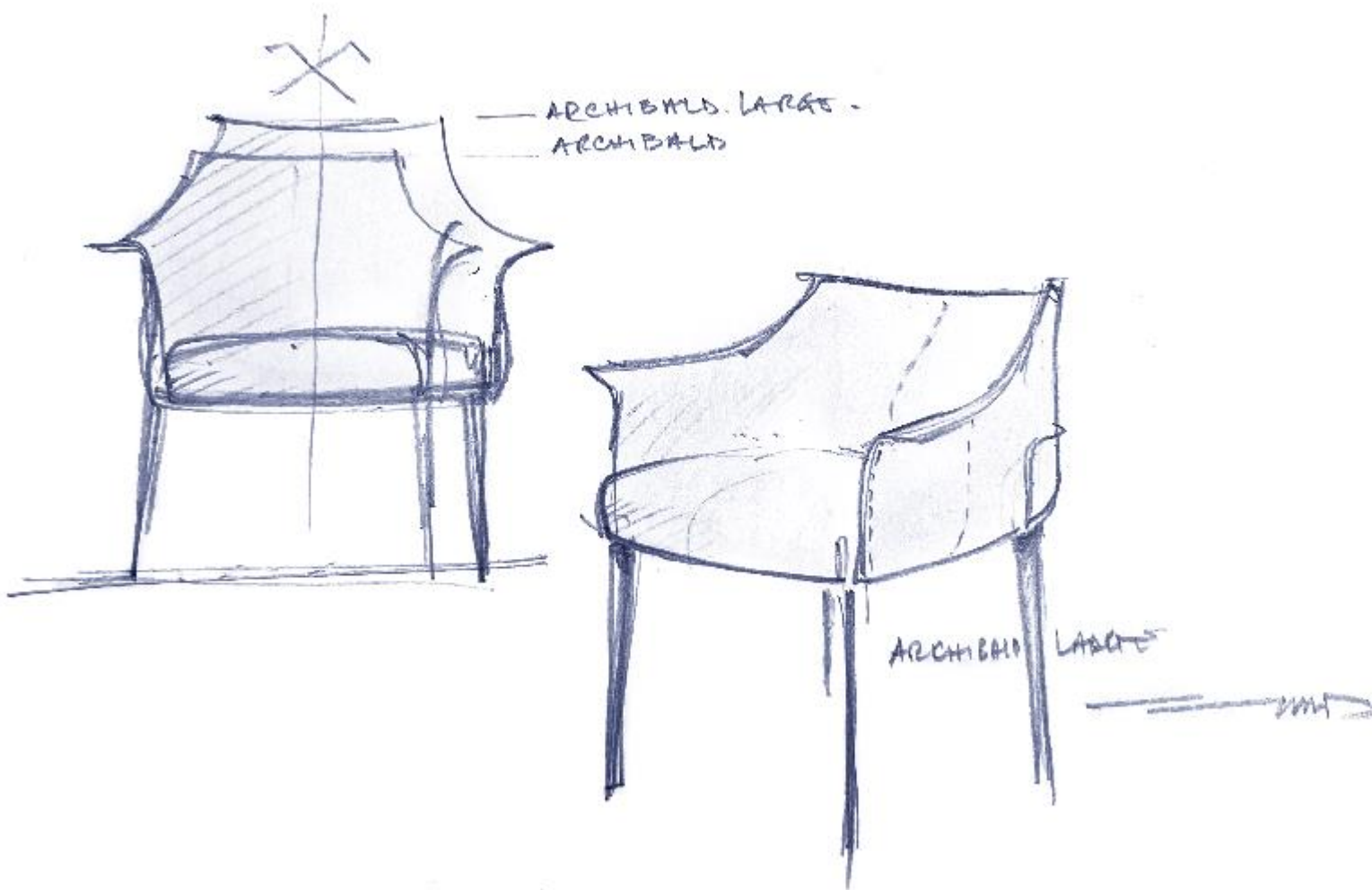

# Archibald Large Dining Chair

Design: Jean-Marie Massaud

RANGE EXTENSION

# Range Extension | Archibald Large Dining Chair



ARCHIBALD DINING CHAIR  
2022



ARCHIBALD LARGE DINING CHAIR  
NEW 2024

## Main Features

- Extension in the living area of a very successful chair in Poltrona Frau
- New higher backrest (+ 7 cm) to better welcome the back
- Wider (+ 4cm) and deeper (+ 2cm) seat to increase comfort
- Only available with the metal base in a titanium or burnished painted finish

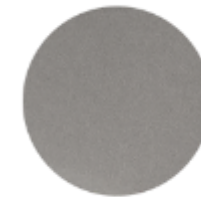

Titanium  
painted  
aluminum



Burnished  
painted  
aluminum



# Range Extension | Archibald Large Dining Chair



→ **The aesthetic details** and precious stitching that characterize the entire Archibald family have remained unchanged.



→ **The backrest has been raised higher** to meet the needs of tall people but also for those who want more structured comfort.



→ **The base has been enlarged** to accommodate the new shell and is supported by 4 conical legs with an oval section made of powder-coated steel.

**PHOTO:**  
Upholstery: SC28 Seppia  
Feet: Burnished

# Range Extension | Archibald Large Dining Chair - Upholsteries and Finishes

## UPHOLSTERY\*

- ColorSphere® (SC)
- Nest
- Soul
- Fabric A
- Fabric B
- Fabric C
- C.O.M.

**PHOTO:**  
Upholstery: SC34 Maggese  
Feet: Burnished painted aluminum



ARCHIBALD  
LARGE DINING CHAIR  
NEW 2024

**PHOTO:**  
Upholstery: SC48 Tonka  
Feet: Burnished painted aluminum



ARCHIBALD  
DINING CHAIR  
2022

## BASE

## NOTES

- \* Upholstery is not removable
- \*\* The wood base finishing is NOT available on the Archibald Large Dining Chair

- Burnished painted aluminum
- Titanium painted aluminum
- Ash in a moka stain (61)\*\*
- Ash in a wenge stain (32)\*\*



# Archibald Task Chair

Design: Jean-Marie Massaud

RANGE EXTENSION

# Range Extension | Archibald Task Chair



EXECUTIVE VERSION



MANAGERIAL VERSION



## New home-office version

- Extension of the home-office seating offer, taking advantage of the iconic design of the Archibald collection
- Conceived and designed with two **backrest heights: high for the Executive version and low for the Managerial version.**
- The **oversized seat with increased depth** gives greater comfort for professional spaces, too
- **Equipped with a 5-spoke base on wheels** and a mechanism for adjusting the seat height and backrest oscillation.

# Range Extension | Archibald Task Chair



→ **The aesthetic details** and precious stitching that characterize the entire Archibald family have remained unchanged.



→ The visual and tactile softness is emphasized by the iconic folds on the backrest.



→ The **depth of the seat has been increased by 20 mm.** compared to the dining version for correct and comfortable **home-office use.**





# Range Extension | Archibald Task Chair – Upholsteries and Finishes



## UPHOLSTERY\*

- ColorSphere® (SC)
- Nest
- Soul
- Fabric A
- Fabric B
- Fabric C
- C.O.M.



PHOTO:  
Archibald Executive  
Upholstery: SC28 Seppia  
Base: Black

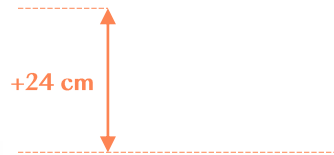

PHOTO:  
Archibald Managerial  
Upholstery: SC34 Maggese  
Base: Black

## 5 SPOKE BASE FINISHINGS

- Polished aluminium
- Black aluminium

## SWIVEL CASTORS

- Self-braking, soft
- Self-braking, hard
- Thermoplastic revolving guides with Teflon protection cap

## CASTOR FINISHES

(in the same finish of the base)

- Black
- Chrome-plated

## UNDER-SEAT MECHANISM COVER

- made in thermoformed ABS in an embossed black finish
- covered in leather to match the shell

## NOTES

\* Upholstery is not removable

# Range Extension | Archibald Task Chair – Technical Features



## ARCHIBALD POLTRONCINA LARGE

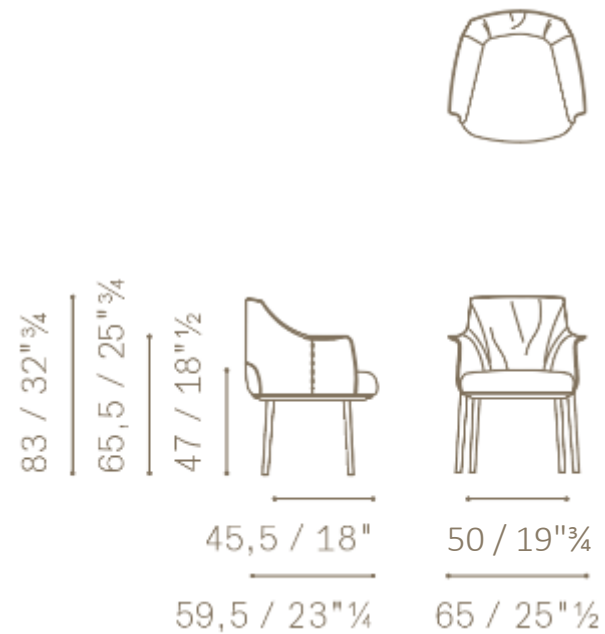

## ARCHIBALD TASK CHAIR MANAGERIAL

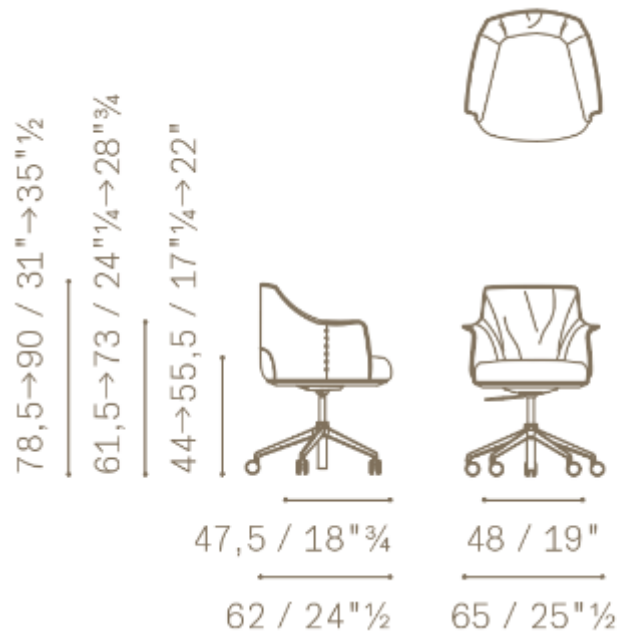

## ARCHIBALD TASK CHAIR MANAGERIAL

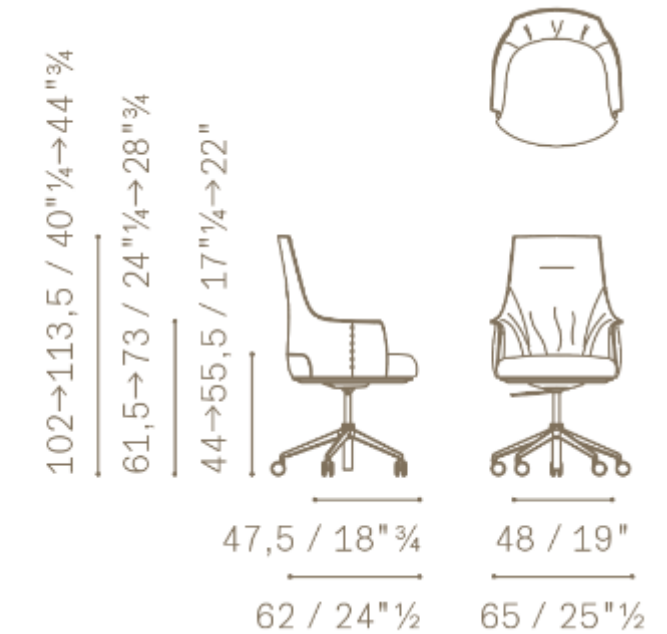

**BACKREST AND ARMREST STRUCTURE.** In moulded rigid polyurethane.

**PADDING.** In soft moulded polyurethane and polyester wadding.

**FRAME.** Birch plywood with polyurethane foam padding and polyester wadding. Suspension. Elastic belts.

**BASE.** Four legs base in solid ash wood in Moka stain or Wengè stain or in powder-coated steel with burnished or titanium finish.

Protective felt pads are placed to protect the floor. Alternatively, it is possible to equip the feet with black nylon protective slides with plastic or felt tips. The height of the chair with felt pads or tips varies about +/- 6 mm.



# Peek-a-Book

Large Desk

Design: Roberto Lazzeroni

RANGE EXTENSION

# Range Extension | Peek-a-Book



## New Large Desk size

- New version with a wider top length increased by 12 inches to reach a more representative and iconic version
- The Large Desk version keep the same wood structure as the standard version, giving a more floating effect to the top which overcome on the sides.
- The width of each drawer is increases by 6 inches while the central working area remain the same size of the standard desk

PEEK-A-BOOK  
2022



183 / 72"

PEEK-A-BOOK  
LARGE DESK  
NEW 2024



214 / 84"

PHOTO:  
Peek-a-Book Large Desk  
Upholstery: SC 254 Steel Blue  
Structure: Ash in a wenge stain (32)

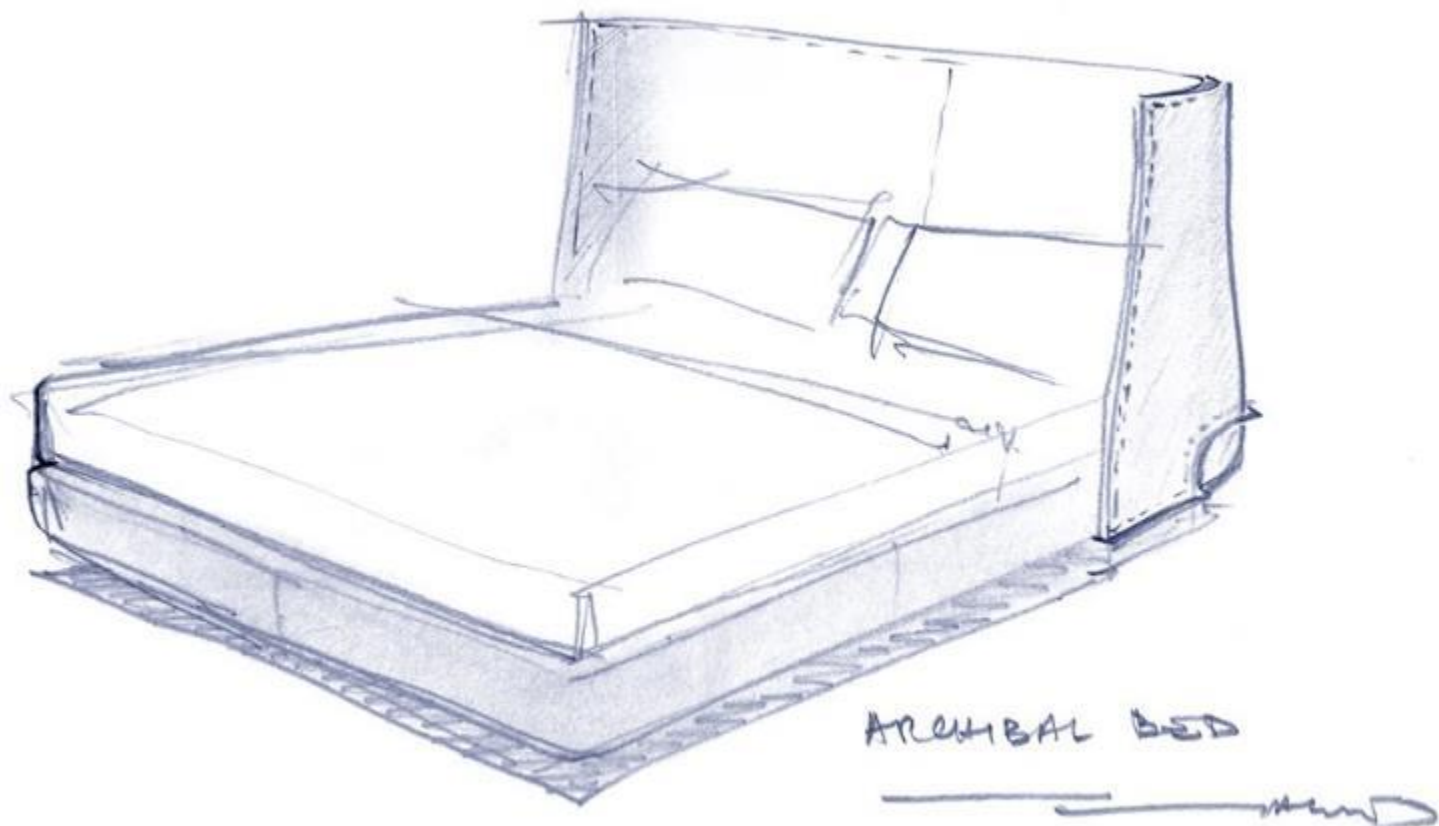

# Archibald Bed

Design: Jean-Marie Massaud

RANGE EXTENSION



# Ampliamento di gamma | Archibald Bed



## Sleeping with Archibald

- New proposal for the sleeping area with the introduction of a product that **expresses a more contemporary language**.
- Improvement of the offer with **a new bed, fully padded and with a low base**, of which we have only two examples on 16 proposals on the price list.
- Run the commercial and iconic success of the Archibald collection by exploring new product types with the same family-feeling.

# Range Extension | Archibald Bed



- The bed is **fully padded with a very low bed frame** and reinterprets the language of the Archibald collection
- The **connection between the headboard and the bed frame** is a founding feature from which we started to create an interesting and original detail.



- A **soft and enveloping headboard** embraces the mattress on the sides.
- An embrace between the two components that clearly preserve their identity and **makes the project unique to read as a single harmonious element**

- The headboard is made of **POLIMEX®**, an **innovative material that is sustainable because it is recycled and recyclable**, which gives it extreme lightness and durability.
- The use of **POLIMEX® allows a 70% reduction in production energy consumption** and a similar reduction in CO<sup>2</sup> emissions during the production and transport phases.



# Range Extension | Archibald Bed – Upholsteries and Finishes



## UPHOLSTERY\*

- ColorSphere® (SC)
- Nest

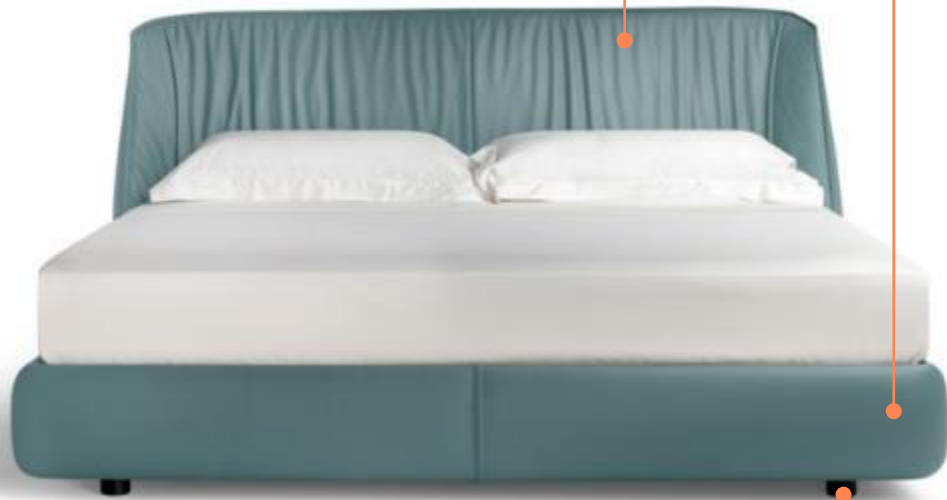

**PHOTO:**  
Archibald Bed 180x200  
Upholstery: SC180 Celadon

## REAR HEADBOARD

- Leather (matching the upholstery)
- Fabric (Poltrona Frau Jacquard fabric)

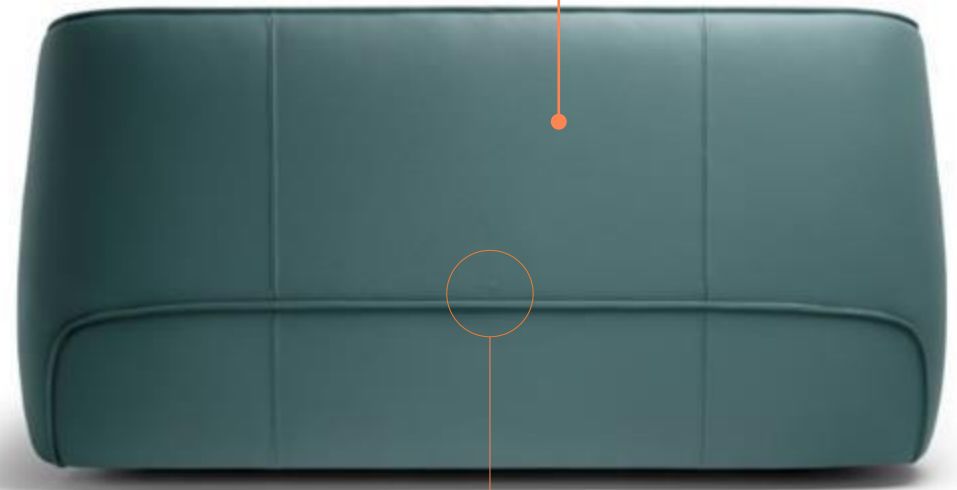

## FEET

- Cylindrical Ø60 h14 in black anodised aluminium with plastic tips
- Cylindrical Ø60 h17 in black anodised aluminium with plastic tips
- Leather covered (with an additional cost)

## LOGO hot-stamped

## NOTES

\* Upholstery is not removable

# Range Extension | Archibald Bed – Technical Features

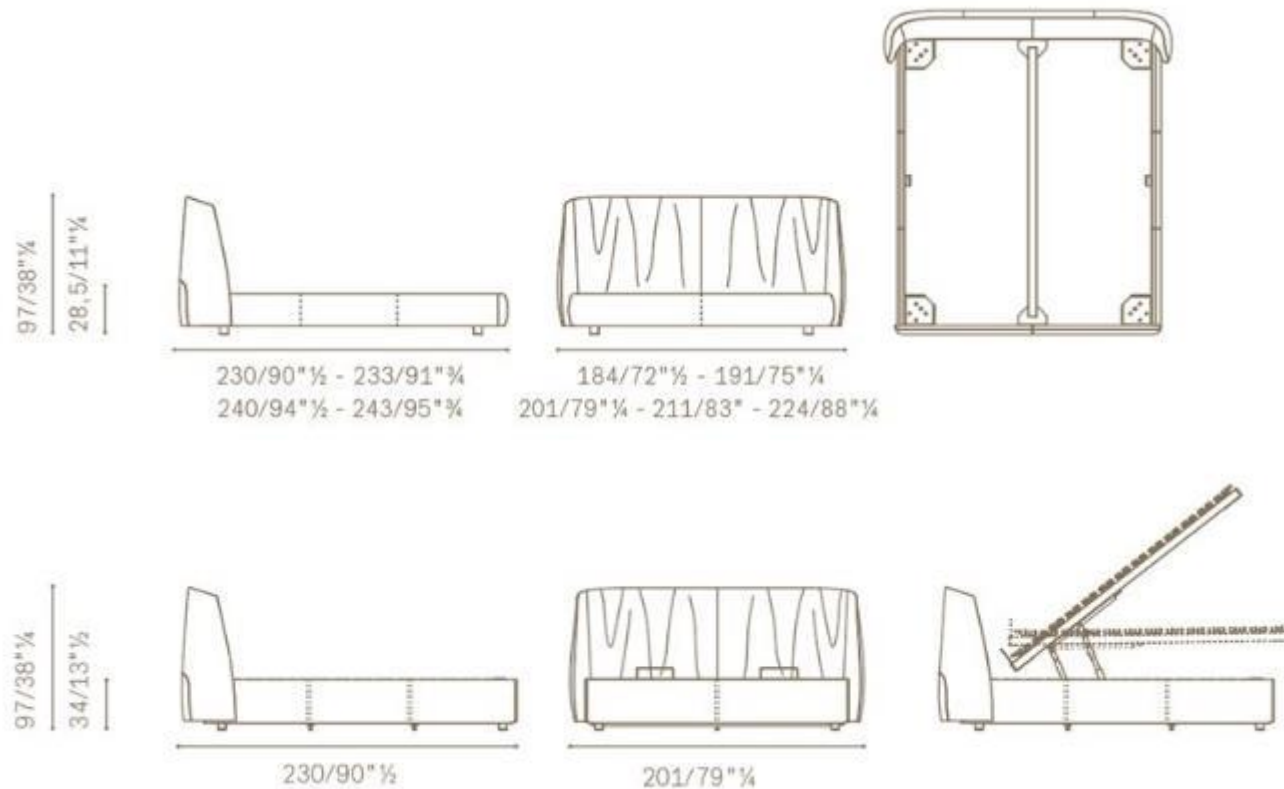

## MATTRESS SIZES:

- 160x200/210
- 170x200/210
- 180x200/210
- King Size 193x203
- Queen Size 153x203
- Bed with Storage Unit

## MATTRESSES:

**ALICUDI** mattress in eco-friendly open micro-cell foam;  
**FILICUDI** mattress in micro-cell foam with “LYMPHA” technology  
**SALINA** mattress in natural latex  
**LIPARI** mattress with pocket springs  
**PANAREA** mattress with “hybrid” technology that combines micro pocket springs and separate micro springs with natural latex and horsehair  
**PIANOSA** Spring mattress.

## BEDSTEAD BASES:

**VESPERO**,  
**BREZZA** adjustable with manual movement,  
**LIBECCIO** adjustable with electrical movement,  
**ZEFIRO** self-adapt with PBS® system.

**HEADBOARD:** Made in Polimex® and birch plywood.

**PADDING:** Padding in polyurethane foam with different density and polyester wadding.

**BASE:** Made of spruce blockboard for the sides and poplar plywood for the footboard. A light polyurethane foam padding wraps the entire base.

**FEET:** Cylindrical aluminium feet black lacquered Ø60 h14 or optional Ø60 h17cm

# Stock'n Roll

Design: Sebastian Herkner



# Stock'n Roll | Design by Sebastian Herkner



## A balance between tradition and innovation, crafts and technology

Born in 1981, Sebastian Herkner studied product design at the Offenbach University of Art & Design, focusing on designing objects and furniture by merging various cultural contexts, combining new technologies with traditional craftsmanship to highlight the multifaceted beauty of the materials and draw attention to fine details.

Since founding his own design studio in Offenbach am Main in 2006, Sebastian has designed products for brands such as ClassiCon, Dedon and Moroso. He has been awarded in 2019 “Designer of the Year” by Maison&Objet in Paris and lastly the EDIDA award for Best Designer of the Year 2022.

# Stock'n Roll | Concept

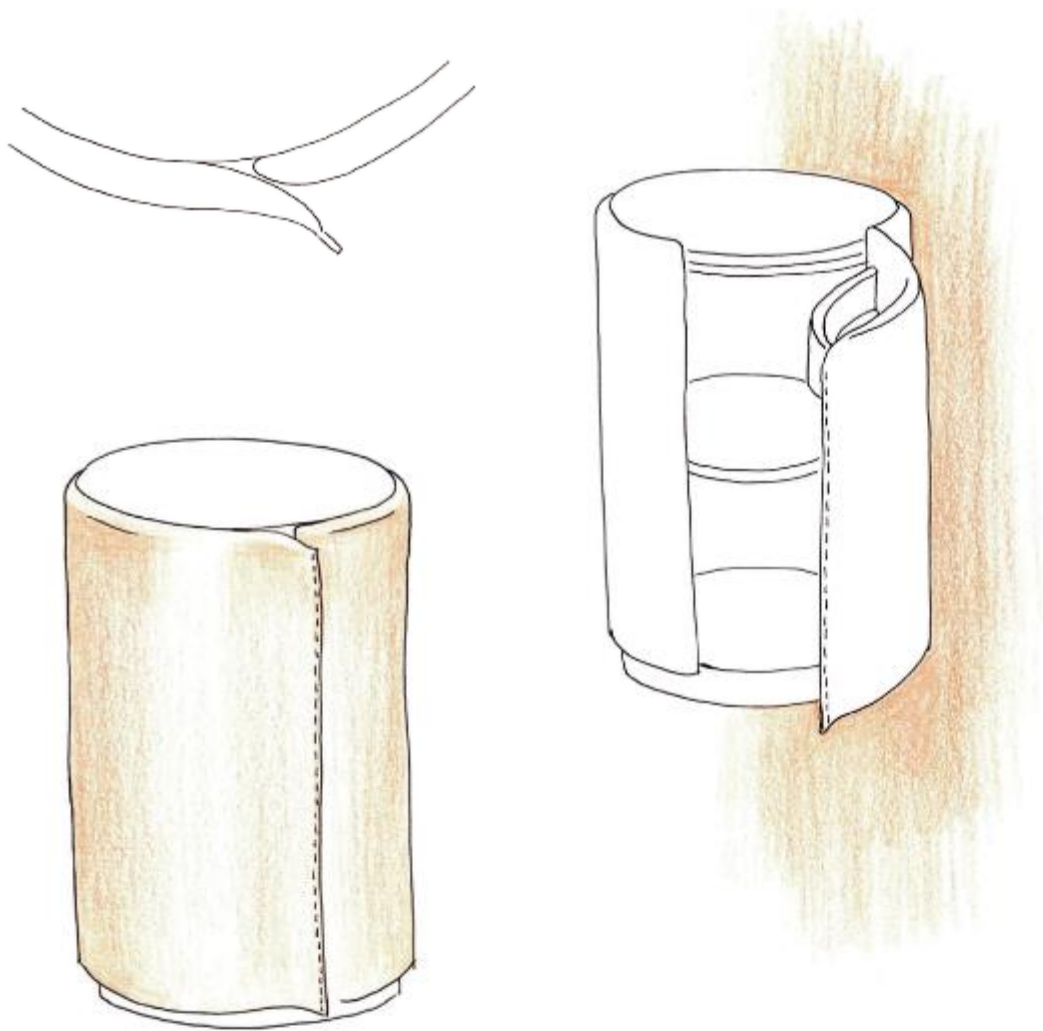

## Sebastian Herkner

«Inspired by jewelry cases and envelopes, the design reflects an intuitive design approach. It is a simple but precious companion for your interior and can be placed next to an armchair or as a bedside table. The cylindrical, container like side table is covered in fine leather which surrounds a polished table-top in marble. A gesture of a handle allows to open the container to place objects inside the side table. Inside the design is covered in Leather as well and offers various shelves.»

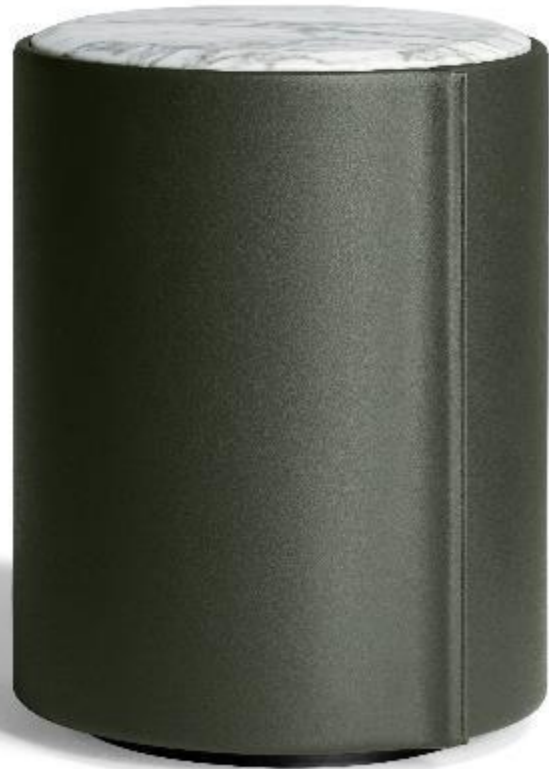

## An enveloping gesture

- The external surface is extremely clean with the leather upholstery which tapers at the end of the door to be finished with a vertical stitching.
- This solution increases the effect of a sheet of leather that wraps the container, leaving only a small flap that folds outside to facilitate opening.
- The cylindrical design is inspired by a 70s mood, like other novelties this year, and is extremely versatile both to enhance the leather covering and to make this object an ideal passe-partout for different types of combinations, from sleeping area to the living room.

## Discovering the precious inside

- Unlike the other bedside tables in our product offering, Stock'n Roll adopts a hinged opening door system inspired by the precious trunks.
- The interior of the cabinet is extremely rich and full covered in leather enriched by stitching details.
- The door is equipped with a curved shaped tray that will be useful to place small objects without having to open the cabinet completely. The internal compartment is divided by a circular shelf also covered in leather.



# Stock'n Roll | Upholsteries and Finishes



## UPHOLSTERY: OUTSIDE / INSIDE

- ColorSphere® (SC) (2-tones allowed\*\*)
- Nest
- Soul



## BASE

- MDF matt black lacquered

## TOP

- ColorSphere® (SC)\*\*
- Semi-brilliant Arabescato marble
- Semi-brilliant Calacatta marble

## SIZES:

Ø 42 / 16"½

H 57 / 22" ½

## NOTES

- \* The two-tones option applies only with Pelle Frau SC
- \*\* The leather top is only available by selecting the Pelle Frau ColorSphere (SC) upholstery.
- \*\*\* The cabinet is available with Right or Left opening door. The picture shows Left opening.





# Nymph

Design: Sebastian Herkner

# Nymph | Concept

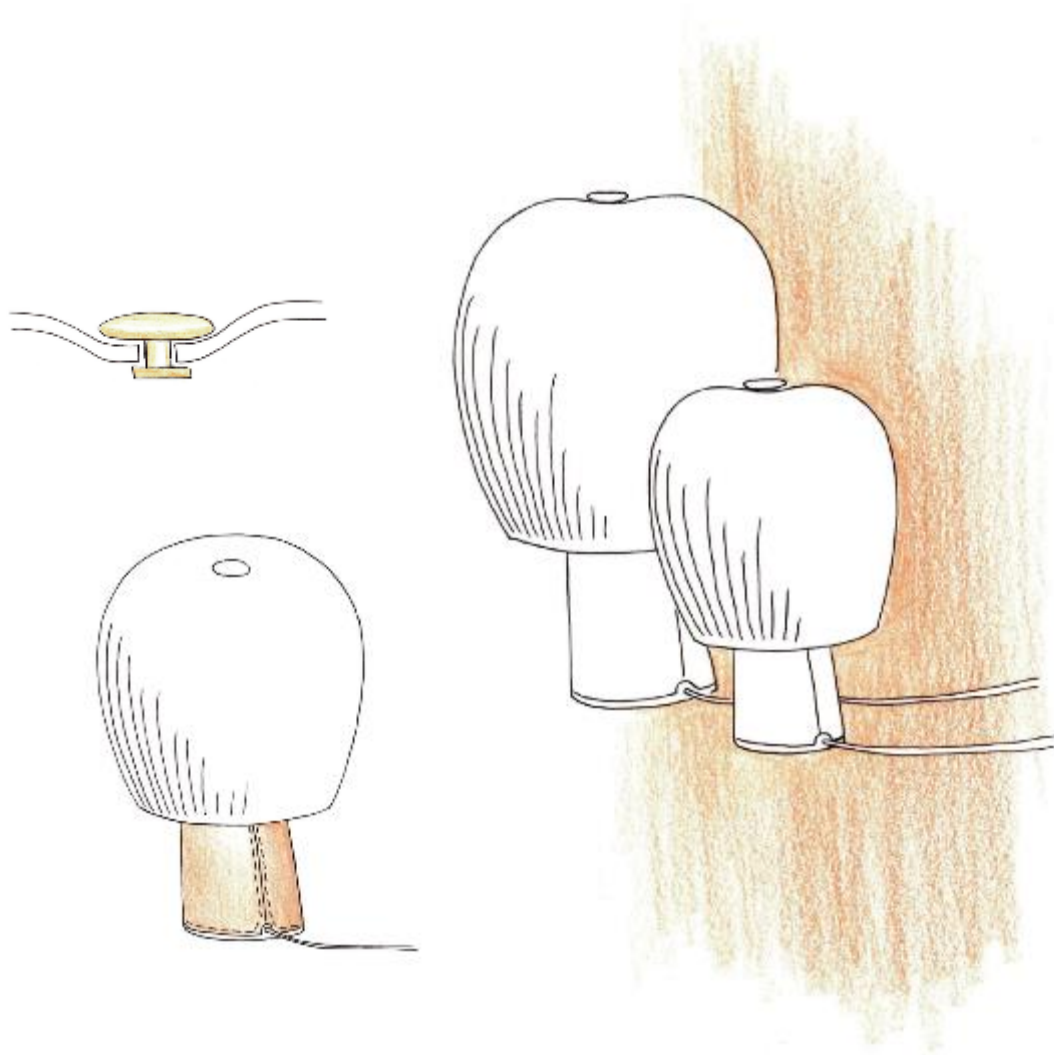

## Sebastian Herkner

«The Nymphs are mystical and charitable beings that serve people. The idea behind them was the inspiration for the collection of lamps made in blown glass and leather. The finely pleated lampshade is floating weightlessly over the leather-covered base. A brass button embedded in the lampshade is reminiscent of upholstery from the company's iconic designs. The button is the switch to control the light and to dim it to various densities. When witched on, the light appears in a unique way and elevates the object into new spheres. »



## Mushroom lamps that will give your room great fairy vibes

- A new collection of table lamps that reinterprets the classic shape of the umbrella lampshade inspired by mushrooms. This typology became popular in the 70s and today is reinterpreted by the designer with an elegant contemporary language.
- Nymph is the first collection of lamps by Poltrona Frau that enhances the color of the Pelle Frau ColorSphere leather covering together with the magic of light diffused by a blown glass.
- The collection consists of two lamp sizes that make it suitable for different environments of the house, from the sleeping area, to the living.

# Nymph | Features



- The body of the lamp has a conical shape and is made of aluminum with details in natural brass finish. It is upholstered in Pelle Frau ColorSphere leather enriched by precious contrasting stitching.
- The lampshade is made of blown rippled glass and has a soft shape slightly tapered down to increase the suspension visual effect from the conical body below.
- On top of the lampshade there is a touch-dimmer in brass that recalls the typical shape of the buttons used for the traditional capitonné by Poltrona Frau.
- A methacrylate cylinder inside the lampshade amplifies the light with 3000 K spread by an integrated 18 W LED powered by 100-240/24V



# Nymph | Upholsteries and Finishes



## LAMPSHADE

- Perla
- Fumé

### SMALL Lamp:

Ø 24 / 9"1/2

H 36,5 / 14"1/4



## UPHOLSTERY\*

ColorSphere® available in 5 colors::



SC 28  
Seppia

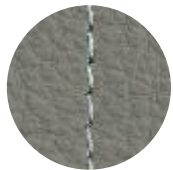

SC 34  
Maggesi



SC 136  
Ginger  
Bread

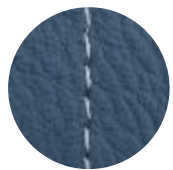

SC 274  
Fresco  
Blue



SC 68  
Sahara



### MEDIUM Lamp:

Ø 35 / 9"3/4

H 52 / 20"1/2

## METAL DETAILS

- Natural Brass



## ACCESSORY\*\*

Kit Plugs and 24V  
Transformer

## NOTES

\* The leather is enriched with precious contrasting color stitching

\*\* The accessory for lamp supply is mandatory



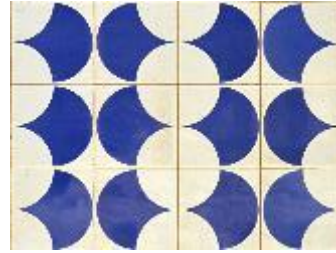

«**Contextual color**, that is inspired by the environment that surrounds us. They are new vibrant and balanced colors at the same time, colors that evoke memories and relate, without overlapping, to those already existing in the various collections of leather Poltrona Frau.»



*Simona Cremascoli Studio ®*



# Upholsteries and Finishes

- Pelle Frau® Nest Impact Less
- Pelle Frau® Motif Knits
- Fabric Collection 2024
- Natural Ash



## A nest in the clouds

- Pelle Frau® Nest becomes Impact Less so that is now tanned without the  $\text{Cr}^3$ , reducing the chemistry and the water consumption in the manufacturing, and using energy 100% coming from renewable sources.
- The hand becomes fuller and rounder expanding the feeling of softness.
- Increased three-dimensionality of the surface.
- More braking touch therefore less slippery for application on sofas and armchairs.
- Smooth and homogeneous gloss look.

# Upholstery | Pelle Frau® Nest Impact Less



→ Existing Colors\*:

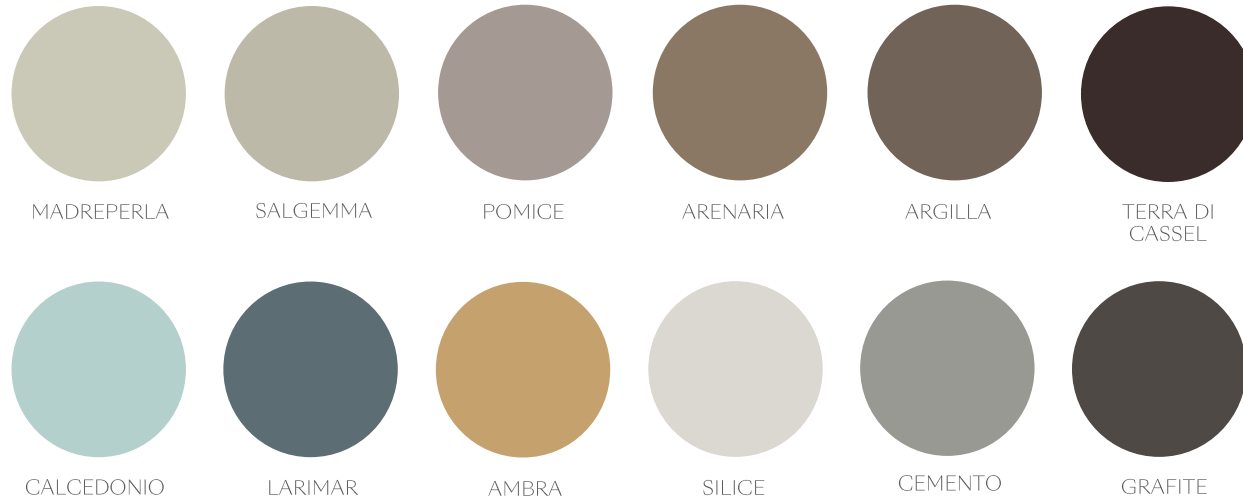

→ **New Colors 2024:**

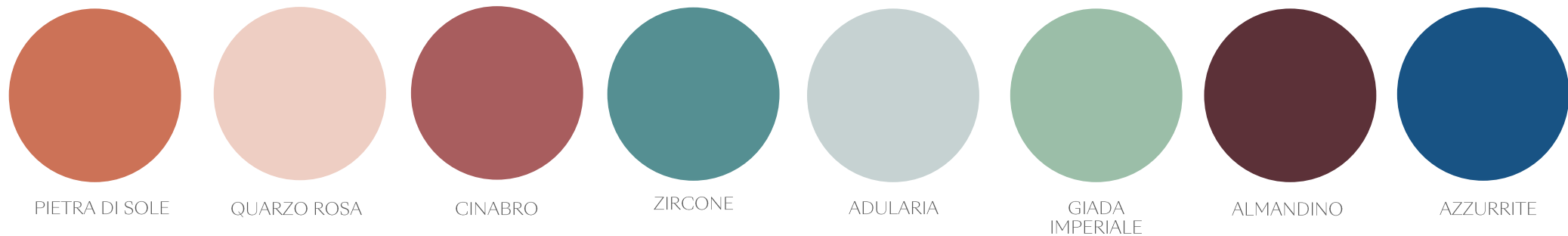

## The new color palette

- Today it consists of a total of 20 colors of which 12 remain from the previous collection.
- Developed 8 new shades that added to the existing colors enhance the whole offering defining new atmospheres
- The new colors are the reference tones of the 2024 color mood that will be presented during the Milano Design Week

### NOTES

\* Phase-out colors which are not included in this chart (Ammonite, Azul, Eliodoro, Granato, Luna, Malachite, Marte, Tufo) will be available until stocks last. Before placing an order with phase-out leather colors please verify through the customer service if there is enough leather available.



## Embossing development on the Pelle Frau® Velvety

- A new hot embossing technique on Pelle Frau® Velvety that allows to design a pattern on the leather through a large cliché.
- Exclusive pattern designed by Poltrona Frau Style & Design Centre inspired by the vegetal handwoven craftsmanship
- Unique three-dimensional effect emphasized by the different shades that the color takes through a perfect balance of hot and pressure.
- 4 colors that are coming from the Pelle Frau Velvety palette which are tonal matching even if more saturated and slightly darker.
- Upholstery available for these products:

→ The color palette:



DEEP  
LAVENDER



SESAME



PAPRIKA



GREY SALT



BRETAGNE GRAN COMFORT



POUF GRANT





## Key Points

- Journey through the different fabric structures from the most material and three-dimensional surface to the most unified and refined.
- In-depth study of the nuances that perfectly match the colors of saddle and leather offering from Poltrona Frau.
- Tailoring fashion references.



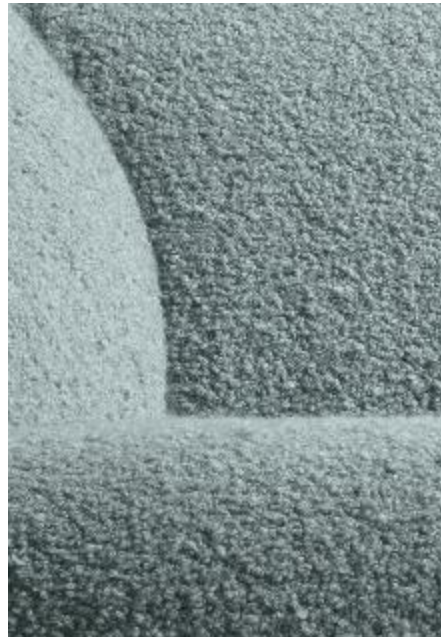

→ The color palette:



MAHOGANY

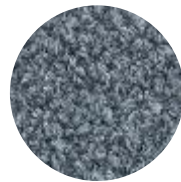

AZUL



BEIGE

## Soft Hug

- It is composed by yarns of different nature, in which the protagonist is a consistent and exuberant bouclette of Alpaca.
- Precious material coming from Peru and spun in Italy, gives life to a very soft and refined Bouclé.
- Available in classic natural beige, in vibrant blue and mahogany colors to match with leather.

| Composition (%)                            | widht (cm) | weight (g/mtl) | martindale (RUBS) | pilling | type of dyeing | BS 5852 | TB 117 | Category |
|--|------------|----------------|-------------------|---------|----------------|---------|--------|----------|
| 45 PC - 27 PL -<br>11 WP - 11 WO<br>- 6 CO | 135        | 970            | 32.000            | 3       | yarn dyed      | PASS    | PASS   | <b>A</b> |

# Upholstery | Kalahari



→ The color palette:

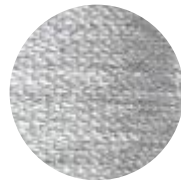

MÈLANGE  
GRAY

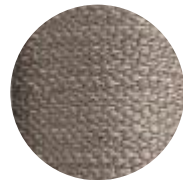

GREIGE



IVORY



CORAL



GOLD

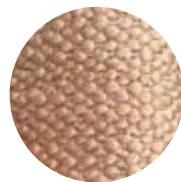

SALMON

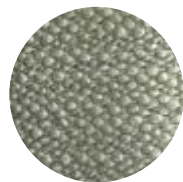

PISTACHIO



FOREST

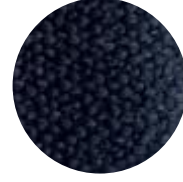

ROYAL  
BLUE



COCOA

## Refined texture

- Canvas fil-a-fil type with a texture and flames given by the characteristic irregularity of the fibers.
- Slightly brilliant, the weave and warp form a small grain of rice that gives the surface a three-dimensional appearance and touch.
- Available with ten colors from darker ones to the lighter contemporary tones perfectly matching with our leathers. .

| Composition (%)                | widht (cm) | weight (g/mtl) | martindale (RUBS) | pilling | type of dying | BS 5852 | TB 117 | Category |
|--------------------------------|------------|----------------|-------------------|---------|---------------|---------|--------|----------|
| 49 PC- 23 PL -<br>23 VI - 5 CO | 140/143    | 890            | 30.000            | 4       | yarn dyed     | PASS    | PASS   | <b>C</b> |



→ The color palette:

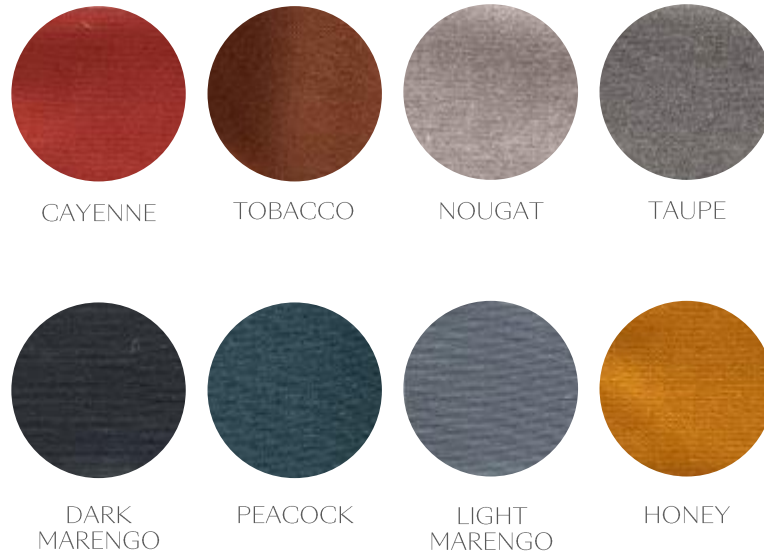

## Satin of fine merino wool

- Densely warped, for a soft and strict fall. Wool Satin is an elegant and bright wool cloth, extremely pleasant and cool to the touch.
- Elastic and highly resistant to abrasion that make it ideal for upholstery of any shape and use.
- The palette consists of 8 colors, solid and deep ranging from neutral tones with mélange yarns typical of the world of knitwear to bright full colors.

| Composition (%)      | widht (cm) | weight (g/mtl) | martindale (RUBS) | pilling | type of dying | BS 5852 | TB 117 | Category |
|----------------------|------------|----------------|-------------------|---------|---------------|---------|--------|----------|
| 75 WV - 20 PL - 5 EA | 148        | 786            | 40000             | 5       | yarn dyed     | PASS    | PASS   | <b>A</b> |

# Upholstery | Haruka



→ The color palette:



LIGHT GREY



LIGHT BROWN

→ **New colors 2024:**



POLLEN

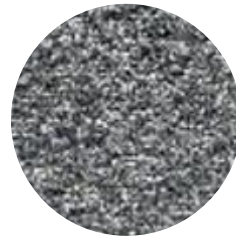

DUSTY BLUE



PEACH BROWN

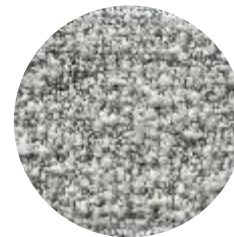

WHITY

## Contemporary taste

- Color range extension of this fabric collection presented in 2023 and highly appreciated from the market.
- It is composed of a raw pure linen base crossed by a bouclé yarn with a wide and discontinuous movement.
- Haruka enhances the exuberance of natural materials typical of craftsmanship, where even irregularity is part of the precious nature of the fabric.
- 70% natural fibers.

| Composition (%)                        | widht (cm) | weight (g/mtl) | martindale (RUBS) | pilling | type of dying | BS 5852 | TB 117 | Category |
|--|------------|----------------|-------------------|---------|---------------|---------|--------|----------|
| 55 LI - 20 VI -<br>15 WO - 5 CO - 5 PL | 140        | 1200           | 35000             | 3/4     | yarn dyed     | PASS    | PASS   | <b>A</b> |





# Natural Ash

Design: Poltrona Frau Style & Design Centre

**NEW FINISHING**





## New Warm Light Contemporary Image

- The new finish will expand the color selection available for product structure in solid ash wood. Only for the Ren collection – actually in solid walnut - we will introduce a new solid ash wood to reach this new finish.
- The gradual introduction of the new natural finish will give a fresher and more contemporary look to our products, perfectly matching with our leather/fabric color palette and suitable for a younger customer target.

### Product Selection 2024



Montera  
Montera Mas



Ginger  
Ginger Ale



Isadora



Viola



Nice



Martha



Times Lounge



Ilary



Bolero  
Bolero Ravel



Ren



Iren

---

# Comfort Upgrade

---





# Let it Be

Design: Ludovica + Roberto Palomba

NEW COMFORT

# Comfort Upgrade | Let It Be



-  POLYURETHANE LOW DENSITY
-  POLYURETHANE MEDIUM DENSITY
-  POLYURETHANE HIGH DENSITY
-  POLYESTER FIBER

NEW Firm Comfort



NEW Soft Comfort

Composition Let It Be - Area 5

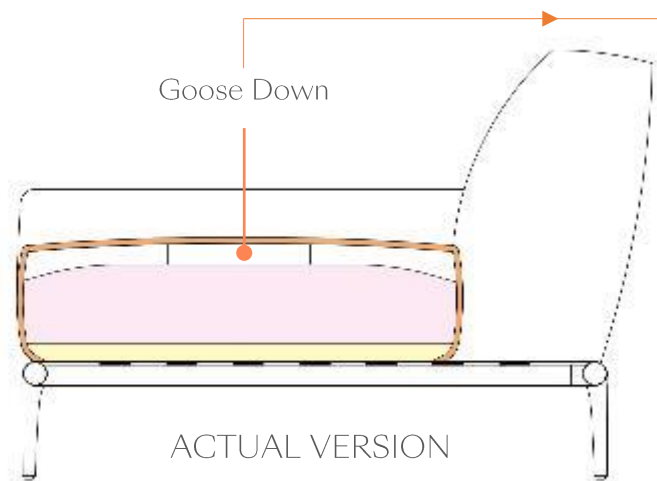

Goose Down

ACTUAL VERSION

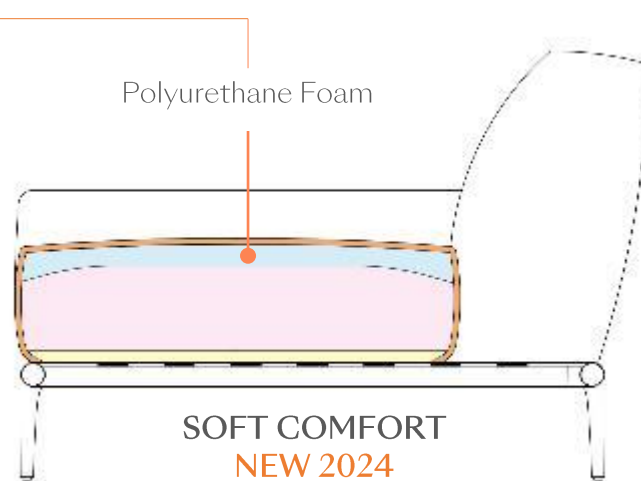

Polyurethane Foam

SOFT COMFORT  
NEW 2024

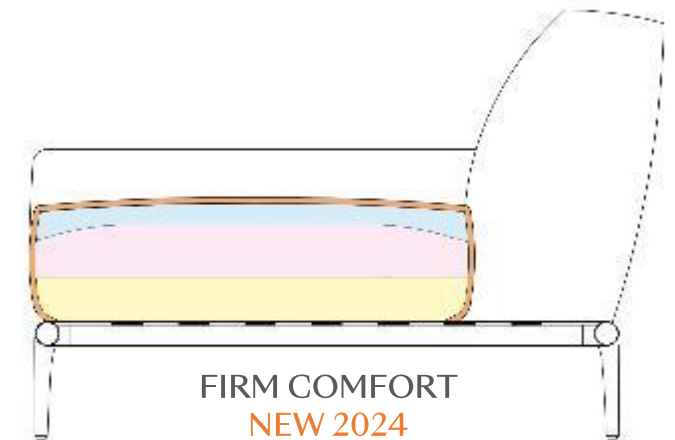

FIRM COMFORT  
NEW 2024

## A new seat cushion

- Available for ordering from 16th April 2024
- The goose down has been replaced by a new low density polyurethane foam with high softness and elasticity. Combined with the polyester fiber allows to reach a comfort similar to feathers. This solution allow a quick recovery of the shape of the seat cushion over time, without having to manually restore the feathers
- **SOFT COMFORT:** replacing the actual seat cushion with feather. It gives a soft and welcoming seating experience.
- **FIRM COMFORT:** with higher density foams resulting less enveloping for a more supportive and formal seat feeling.

---

Imagine **Reality**

---





# Vanity Fair XC Imagine Edition

Design: Poltrona Frau Style & Design Centre  
Style: Barnaba Fornasetti







# Fornasetti x Poltrona Frau | Vanity Fair XC Imagine Edition



## New printed leather types

- The leather simulate the silk-screen printing technique
- The leather brings out Fornasetti's features and their world
- A technical solution which intensifies the collaboration's esthetic

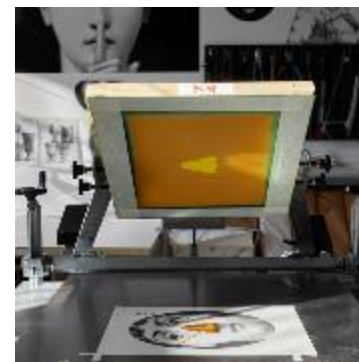



# Fornasetti x Poltrona Frau | Vanity Fair XC Imagine Edition





# Fornasetti x Poltrona Frau | Vanity Fair XC Imagine Edition



## The sun and the moon

- The portrayed subjects are the interpretation of the **imagine** theme
- Only 50 armchairs are available **individually numbered** on the plate positioned under the moon.



50 mm

33.5 mm

95 mm

65 mm

FORNETTI x



Vanity Fair XC Imagine Edition  
1 of 50





---

Imagine

**Culture meets Craft**

---



# Oswald Boateng X Poltrona Frau

- The collection
- Pelle Frau® Nubuck Tribal
- Velvet Fabric Tribal
- Pelle Frau® Kenté

# Ozwald Boateng x Poltrona Frau | The collection



## When the innovation meets the tradition

- The Ozwald Boateng x Poltrona Frau collection is characterized by special patterns coverings realized by the designer as a celebration of African culture and the English textile tradition.
- It's a capsule collection consisting of iconic Poltrona Frau products, from upholstered items to accessories.
- 3 different types of upholstery and sophisticated print technique
- Colors express the strenght of this collaboration



→ Available products:



CHESTER  
CHESTER ONE  
CHESTER LINE



VANITY FAIR  
VANITY FAIR XC



GINGER  
GINGER ALE



MARTHA



PEEK A BOOK



REN BOOKCASE



MANCALA



CANDELE  
CUSCINI DECORATIVI  
TAPPETO



# Ozward Boateng x Poltrona Frau | Pelle Frau® Nubuck Tribal



YELLOW

PURPLE

GREEN

RED

## Key points

- Warm embossing technique, a complex procedure used for the first time on Pelle Frau® Nubuck Tribal.
- Tribal pattern ton sur ton brings out the Pelle Frau® Nubuck's features which has a texture that could be recognized on the product moving close to it and touching it
- The 4 colors evoke the African culture
- Reinterpretation of Chester sofas.
- It is also available the decorative pillows' covers



CHESTER  
CHESTER ONE  
CHESTER LINE



decorative pillows  
47x47 cm



# Ozward Boateng x Poltrona Frau | Velvet Fabric Tribal

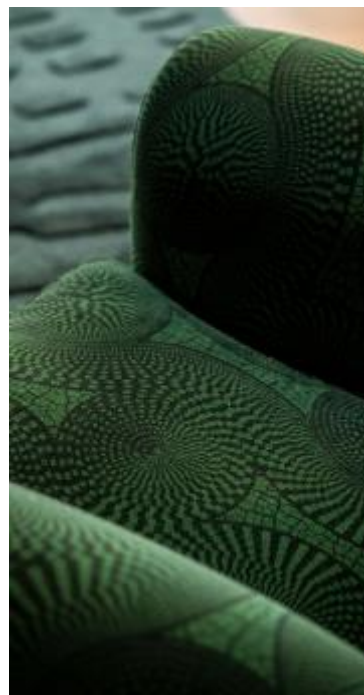

YELLOW



PURPLE



GREEN

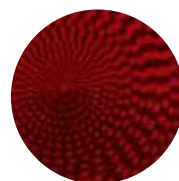

RED

## Key points

- Digital print on velvet fabric
- The motif express itself by the contrast with the monocromatic base coat
- The upholstery is available on Vanity Fair e Vanity Fair XC.
- Extention of 2024 collection: possibility to upholster the inner body of Martha armchiar matching the Cuoio Saddle Extra.



VANITY FAIR  
VANITY FAIR XC



MARTHA  
MARTHA A DONDOLO

# Ozwald Boateng x Poltrona Frau | Velvet Fabric Tribal

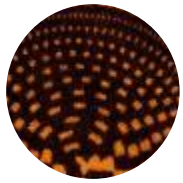

YELLOW



PURPLE

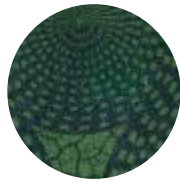

GREEN

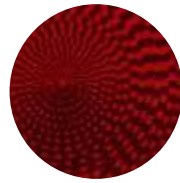

RED



MARTHA  
MARTHA A DONDOLO



VANITY FAIR  
VANITY FAIR XC



## Velvet Fabric Tribal

→ Digital print on velvet fabric.



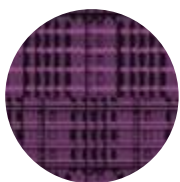
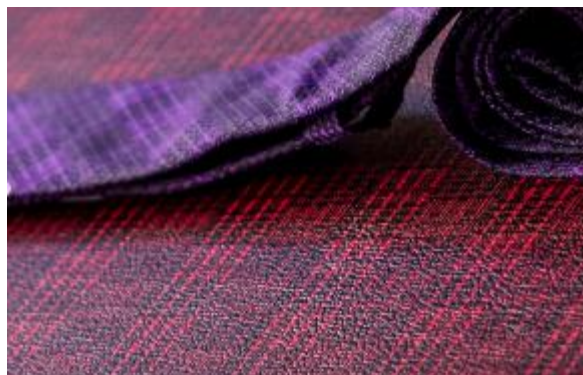

PURPLE



BLUE

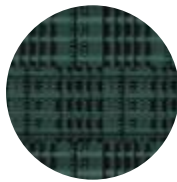

GREEN

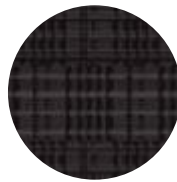

BLACK



RED



YELLOW

## New exclusive pattern

- Digital print on Pelle Frau® ColorSphere.
- The new pattern is sketched by Ozwald Boateng, inspired by the traditional African Kenté fabric, distinguished by abstract patterns with dark and light intense colors, and a strong symbolic meaning
- The 6 colors evoke the African fabric culture
- The upholstery is available for these products: :



GINGER  
GINGER ALE



PEEK A BOOK  
PEEK A BOOK  
LARGE DESK



REN LOW BOOKCASE  
REN HIGH BOOKCASE  
REN FREESTANDING  
BOOKCASE

# Ozward Boateng x Poltrona Frau | Pelle Frau® Kenté

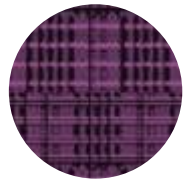

PURPLE



BLUE



GREEN

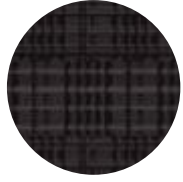

BLACK



RED



YELLOW



GINGER  
GINGER ALE



PEEK A BOOK  
PEEK A BOOK  
LARGE DESK



REN LOW BOOKCASE  
REN HIGH BOOKCASE  
REN FREESTANDING  
BOOKCASE



## New Kenté pattern

→ Digital print on Pelle Frau® ColorSphere.



---

Imagine **Well-Being**

---

# Beautilities Collection

- Mirrors
- Rugs
- Tableware
- Office collection
- Objects
- Pet Collection
- Wall decoration

A close-up photograph of the upper backrest of a chair, showing a teal-colored leather with a wavy, organic shape and visible stitching along the edges.

# Squash Collection Mirror

Design: Faye Toogood

# Squash Collection | Mirror - Concept



“I wanted to bring some of my own heritage to the collaboration, and so you’ll find details that nod to English Folk Art. The idea to create leather mirrors was my personal response to early English leather folk work.”

**A conversation between something hard and something soft.”**

*foogood*



# Squash Collection | Mirror - Concept

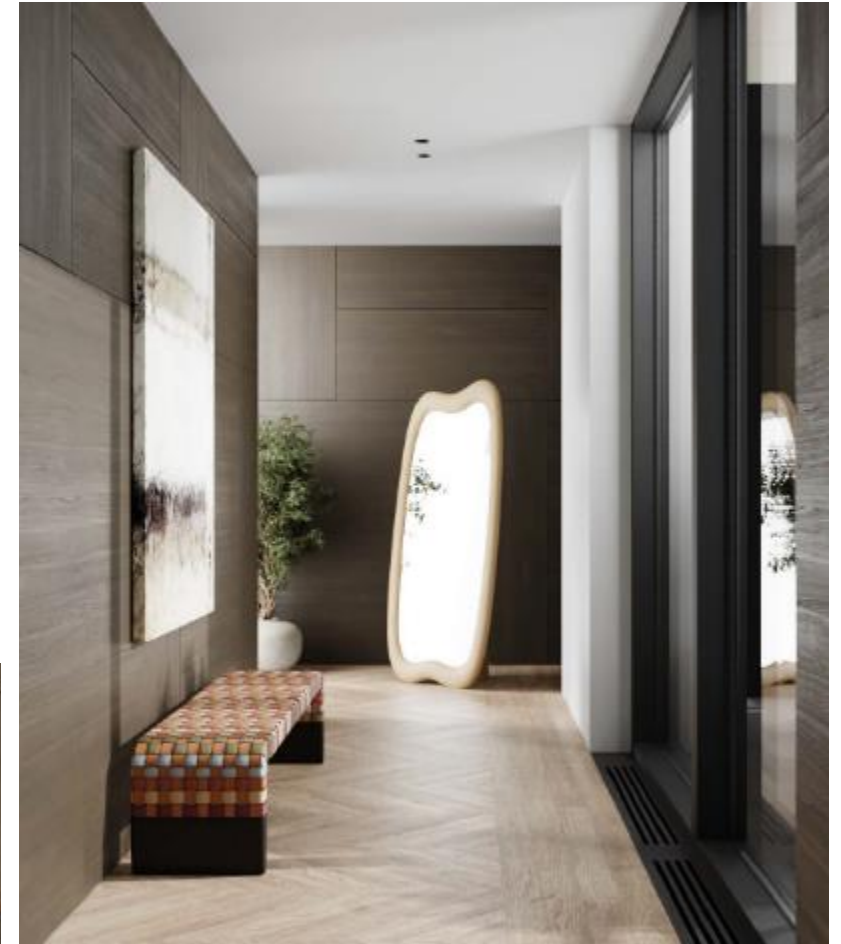

Smooth, hard glass is cushioned  
in tactile, curving frames.

# Squash Collection | Mirror - Concept



Free Standing  
OPTION



SQUASH LONG  
MIRROR 85X190



SQUASH WALL  
MIRROR 80X100



SQUASH POCKET  
MIRROR



UPHOLSTERY\* PELLE  
FRAU® SC | ColorSphere®

- ColorSphere® SC 92 Garnet
- ColorSphere® SC 254 Steel Blue
- ColorSphere® SC 67 Chiodi di Garofano

## Colors

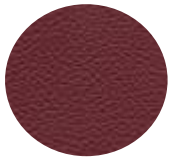

SC 92 Garnet

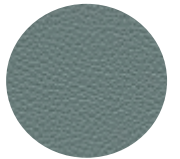

SC 254 Steel Blue



SC 67 Chiodi  
di Garofano

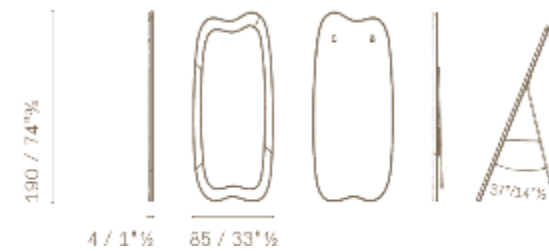

# Squash Collection | Mirror - Concept



UPHOLSTERY\* PELLE FRAU® SC | ColorSphere®

- ColorSphere® SC 127 Siam
- ColorSphere® SC 254 Steel Blue
- ColorSphere® SC 68 Shara



## Colors



SC 127 Siam

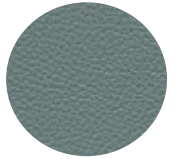

SC 254 Steel Blue



SC 68 Shara





# Squash Collection Rugs

Design: Faye Toogood



# Squash Collection | Rugs



## DYER'S ALKANET

Known as alcañá, it's a Boraginaceae family's evergreen shrub typical of the Mediterranean area. From the roots a coloring **red** substance could be obtained.



**Natural dyes and natural fibres replicate hand painting** in the closest way, and the deep pile and fuzzy threads evoke the blended look of brushstrokes.

*foogood*

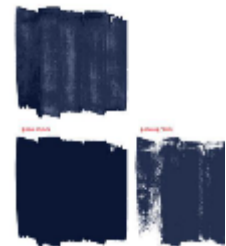



# Squash Collection | Rugs



The rhythm and imperfections of a drawn line or painted stroke capture the pulse of creativity and offer a direct connection to the artist.

*foogood*



# Squash Collection | Rugs



Hand painting is one of Toogood's most distinctive trademarks. Each square was hand painted, and this artwork was translated into textile using Berber knotting.

*toogood*



# Squash Collection | Rugs



250 \ 98,42'



250 \ 98,42'

250 \ 98,42'



340 \ 133'



## OPTIONS:

- Size:
- 250 / 250 cm
  - 250 / 340 cm
- Colors:
- Color Blue
  - Color Brown







# Rugs

Design: Poltrona Frau Style & Design Centre

- **Kabir** (Nuovo prodotto)
- **Calamandra** (Ampliamento di gamma)

# Rugs | Kabir



TAUPE



CHARCOAL



CORAL



FOREST



OTTANIO



CHAMPAGNE



## Colors borrowed from the earth, sand, stone

A texture that suggests softness; the fringe as a sartorial edge alive. A carpet with a refined taste, which combines refinement and naturalness, tradition and hi-tech yarn.



Size: 250 x 300 cm  
80" x 120"  
Fleece composition: 100% recycled PET  
Height: 0,20"  
Technique: Handwoven  
Origin: India  
Colors: CORAL-CHARCOAL-TAUPE-FOREST-OTTANIO-CHAMPAGNE



# Rugs | Calamadra



GREY



WARM GREY



STEEL GREY



RUST



OTTANIO



FOREST



CHAMPAGNE



**Size:** 100" x 120"; 120" x 160"  
**Fleece composition:** mix of Neozeland wool and Srdinian wool.  
**Haight:** 0,045"  
**Tecnique:** Handloomed  
**Origin:** India  
**Finishing:** shaved fleece; the carpets are handwashed and handchiselled.

**They stand out for the pleasant tactile feeling they give**

Made with a precious raw material, a combination of New Zealand wool and Sardinian wool from which a very soft, compact and resistant yarn is obtained. New extension of color, warm, which allows to make the rooms of the house cozy.

# Tableware Collection

Design: P.F. Style & Design Centre  
+ Giobagnara





# Tableware Collection | The collection



## Culinary and convivial experience of class and refinement

The collection ranges from leather coasters to champagne buckets, offering a variety of elegant and functional elements to enrich the dining experience. Each piece is the result of impeccable craftsmanship and refined design, ensuring a touch of class and sophistication.

GIOBAGNARA

X



# Tableware Collection | The collection



## NAPKIN RING

Materials:  
Pelle Frau Color Sphere® + polished chrome



## COASTER HOLDER

Materials:  
Pelle Frau Color Sphere® + walnut wood



## UNDERPLATE

Materials:  
Pelle Frau Color Sphere® + alluminium

## Colors

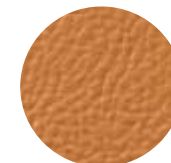

SC 66 India

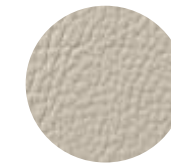

SC 31 Quarzo Fumè



# Tableware Collection | The collection



## ROUND TRAYS

Materials:  
Pelle Frau Color  
Sphere® + walnut  
wood



## RECTANGULAR ROUNDED TRAYS

Materials:  
Pelle Frau Color  
Sphere® + walnut  
wood



## PLACEMAT HOLDER

Materials:  
Pelle Frau Color  
Sphere® + walnut  
wood

## Colors

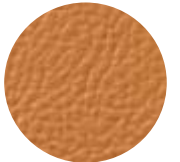

SC 66 India



SC 31 Quarzo Fumè

# Tableware Collection | The collection



## CHAMPAGNE BUCKET WALLET CHAMPAGNE BUCKET

Materials:  
Pelle Frau Color Sphere® +  
polished chrome



## BED TRAY

Materiali:  
Pelle Frau Color Sphere® +  
metallo



## BOTTLE COOLER

Materiali:  
Pelle Frau Color Sphere® +  
polished chrome

## Colors



SC 66 India



SC 31 Quarzo Fumè





# Office Collection

Design: PF Design & Giobagnara

# Office Collection | The collection



**Sophisticated and practical solutions for professional environments**

The accessories are designed to offer functionality and versatility, satisfying the practical needs of working environments without compromising on style and refined aesthetics.

GIOBAGNARA

x





# Office Collection | The collection



## SINGLE PEN HOLDER

Materials:  
Wood structure + Pelle Frau  
Color Sphere®



## FLAT PEN HOLDER

Materials:  
Wood structure + Pelle Frau  
Color Sphere®



## DESK BLOTTER

Materials:  
Metal slab + Pelle Frau  
Color Sphere®



## MOUSE PAD

Materials:  
Metal slab + Pelle Frau  
Color Sphere®

## Colors

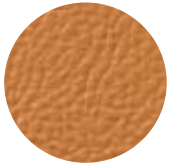

SC 66 India



SC 31 Quarzo Fumè

# Office Collection | The collection



## ENVELOPE HOLDER

Materials:  
Wood structure + Pelle Frau  
Color Sphere®



## A4 PAPER TRAY

Materials:  
Wood structure + Pelle Frau Color  
Sphere®



## WASTEPAPER BIN

Materials:  
Wood structure + Pelle Frau Color  
Sphere®



## LAPTOP TRAY

Materials:  
Pelle Frau Color Sphere® + Pelle  
Nabuk

## Colors

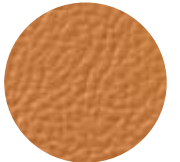

SC 66 India



SC 31 Quarzo Fumè



# Office Collection | The collection





# Pet Collection

Design: Poltrona Frau Style & Design Centre

AMPLIAMENTO DI GAMMA

# Pet Collection | Extension of the range



## HARNES JACQUARD

Materials:  
Pelle Frau Color Sphere® +  
Jacquard fabric + metal finishes

Dimensions:  
XS: 38 cm x 48 cm  
S: 48 cm x 56 cm  
M: 57 cm x 72 cm  
L: 70 cm x 92 cm

XS: 15" x 20"  
S: 20" x 22"  
M: 22,5" x 28,5"  
L: 28" x 36"

## Colors



SC 66 India



SC 256 UME

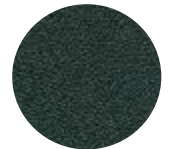

SC 209 Cypress



# Pet Collection | Extension of the range



## COLLAR JACQUARD

Materials:  
Pelle Poltrona Frau Color Sphere®  
+ Jacquard fabric + metal

Dimensions:  
XS: 12" x 0,60"  
S: 14" x 0,60"  
M: 18" x 1"  
L: 22" x 1"

XS: 30 cm | h 1,5 cm  
S: 35 cm | h 1,5 cm  
M: 45 cm | h 2,5 cm  
L: 55 cm | h 2,5 cm



## LEASH JACQUARD

Materials:  
Pelle Frau Color Sphere® +  
Jacquard fabric + metal

Sizes : S / M

## Colors

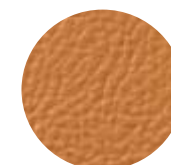

SC 66 India

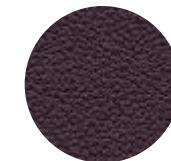

SC 256 UME

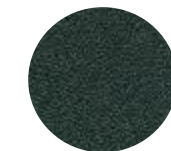

SC 209 Cypress



# Pet Collection | Extension of the range



## DOG BOWL

Materials: glazed ceramic  
Technique: 3 fire casting



## PET PILLOW

Materials: Beady fabric ( 67%VI – 33%CO-8%L); unsheathed and hypoallergenic inner pillow

## PET BOWL PAD

100% water-repellent PL laminated with soft eco-leather on the bottom.



SOLD OUT



DOG BED - NUTMEG



DOG BED - POPPY



DOG BED - CARDAMOMO





# Water Illusion

Design: Assia Karaguiozova

# Pet Collection | Extension of the range



## Natural light reflector

The Collection interprets, in its various expressions, the continuous movement of water, that, with a spontaneous gesture, stops in sinuous, unique and unrepeatable manifestations, in the crystallized transparency and materialized by glass.

*Assia Karaguiozova*

## Colors



Sunny side



Moon Bounces



Esmerald whispers



# Water illusion | Extension of the range



## BOWLS

Materials: Handcrafted and paste-colored fused glass

Dimensions:  
Height (max) = 13 cm  
Diameter (max) = 30 cm

## Colors



Sunny side



Moon Bounces



## BOWLS

Materials: Handcrafted and paste-colored fused glass

Dimensions:  
Height (max) = 15 cm  
Diameter (max) = 43 cm



Esmerald whispers



# Water illusion | Extension of the range

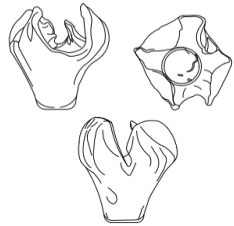

## VASE S

Materials: Handcrafted and paste-colored fused glass

Dimensions:  
Height (max) = 25 cm  
Diameter (max) = 22 cm  
Base diameter = 10 cm

## Colors



Sunny side



Moon Bounces



Esmerald whispers



## VASE L

Materials: Handcrafted and paste-colored fused glass

Dimensions:  
Height (max) = 30 cm  
Diameter (max) = 30 cm  
Base diameter = 10 cm



# Tableau N'est saison

Design: Simona Cremascoli

# Tableau | Extension of the range



Hiver  
2011



Automne  
2011



Printemps  
2011



Ete  
2011

As in a canvas,  
creativity and  
color meet the  
sensual aesthetic  
pleasure and  
warmth of the  
material

- The Tableau, designed by Simona Cremascoli, are decorative squares with simple, geometric graphics.
- This year has been proposed an extension of coloring that completes the collection of the 4 Seasons, adding the one representing the "Out of Season".

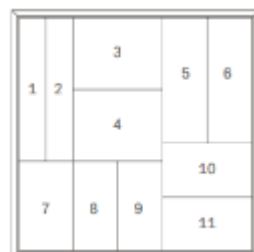
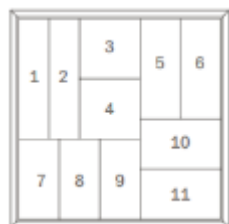

## N'Est Saisons - NOVITÀ 2024

- Giada imperiale
- Cinabro
- Quarzo rosa
- Pietra di sole
- Adularia
- Zircone
- Almandino

---

Imagine  
**Boundless Living**

---



# Outdoor Collection

- Mirabell Collection
- Solaria Collection
- Sparkler
- Cestlavie Outdoor
- Outdoor Upholsteries

# Mirabell Collection

Design: GamFratesi

# Mirabell Collection | Design by GamFratesi

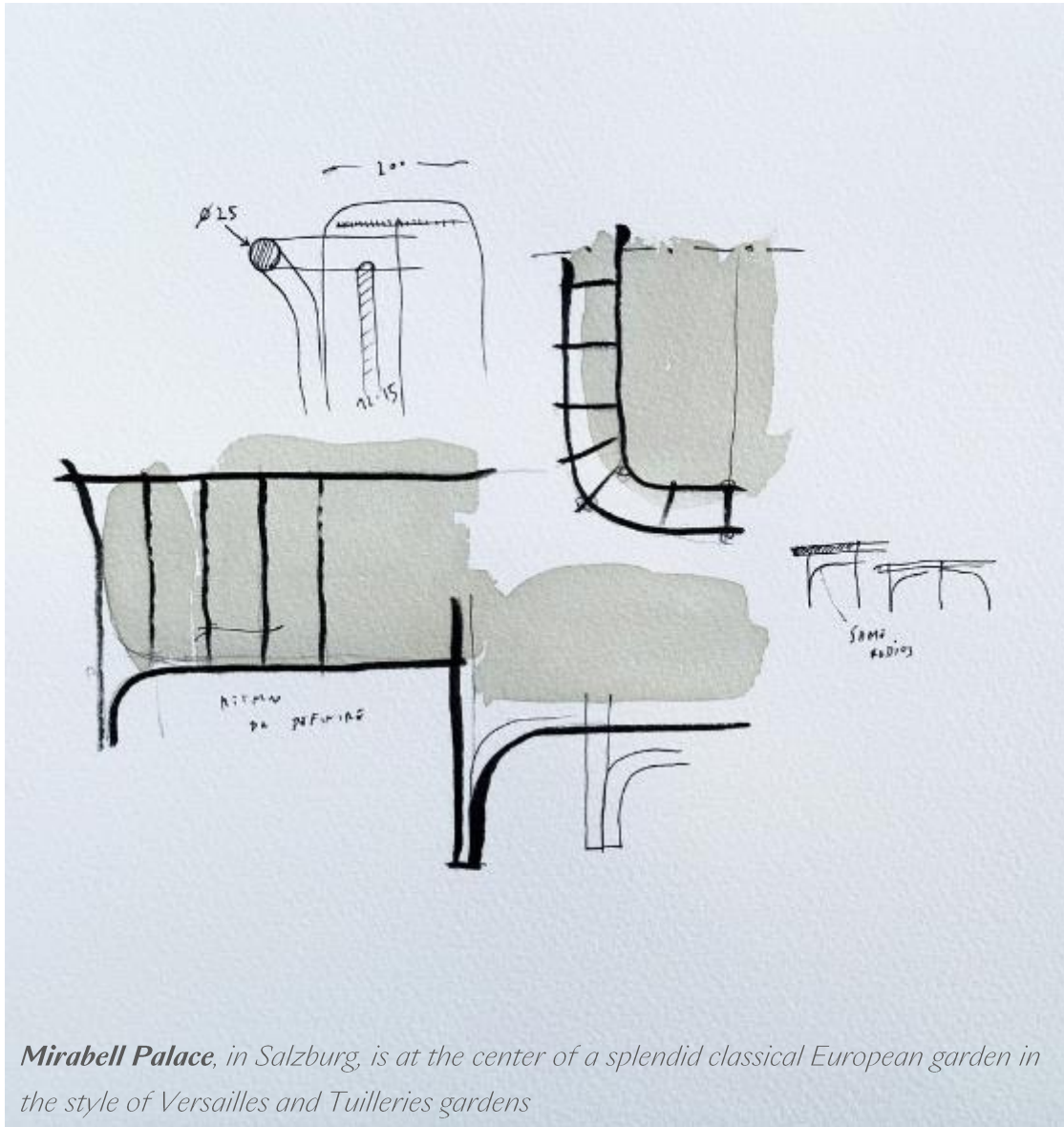

«MIRABELL Collection is inspired by **the classic style of metal benches and sofas typical of the 20th century in France** which were placed in parks or elegant private gardens. A series of lines, which create a rhythm for the entire backrest. As well a reference to **products made of rattan typical of the outdoor world** where the elements follow one another and intertwine with each other, creating a large basket that becomes an element to accommodate the cushions.»



*Mirabell Palace, in Salzburg, is at the center of a splendid classical European garden in the style of Versailles and Tuilleries gardens*



# Mirabell Collection | Key Points



TRADITION AND INNOVATION

HIGH COMFORT



100% OUTDOOR

LIGHT AND STURDY

100% REMOVABLE UPHOLSTERY





→ MIRABELL Large 2-Seater Sofa



## Tradition and innovation

- Mirabell is a collection of sofas and coffee tables with a **completely welded and hand-finished aluminum tubular frame**.
- The fluid design of the frame run continuously without interruptions or joints, pay homage to the classic colonial collections in bamboo and rattan and **contain large, soft and comfortable cushions**.
- The aluminum frame is **particularly light and easy to move in outdoor space**. An important feature for this informal sofa.

# Mirabell Collection | Sofas



→ The large and welcoming cushions of the sofa are characterized by **elegant folds typical of the world of tailoring.**

→ **The aluminum tubes that design the frame** follow an increasing movement on the armrest and equidistant on the backrest



→ The sofa stand on **feet made of doubled tubes** which refer to tradition and colonial rattan furniture and lighten the proportion of the seat volumes.

# Mirabell Collection | Sofas - Padding

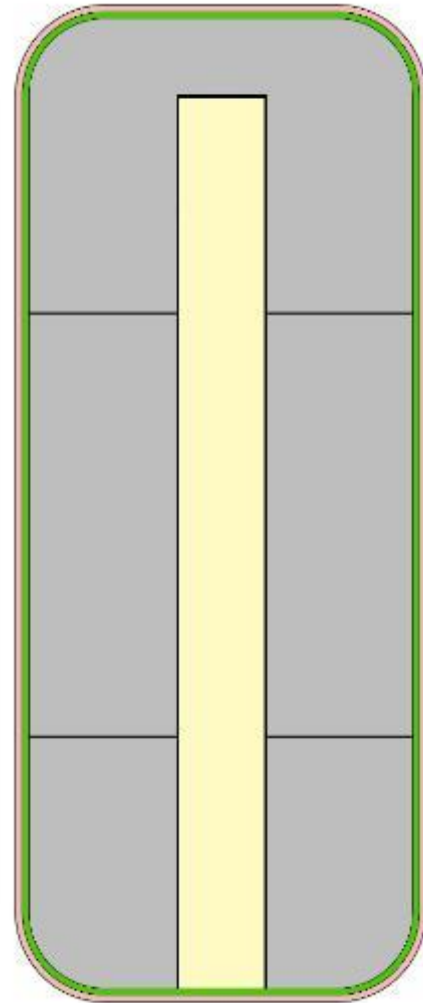

ARMRESTS AND BACKREST CUSHIONS SECTION

- LOW DENSITY POLYURETHANE (DRENANTE)
- MEDIUM DENSITY POLYURETHANE (DRENANTE)
- POLYESTER FIBER
- DRAINING FABRIC
- WATERPROOF FABRIC
- OUTDOOR FABRIC OR LEATHER

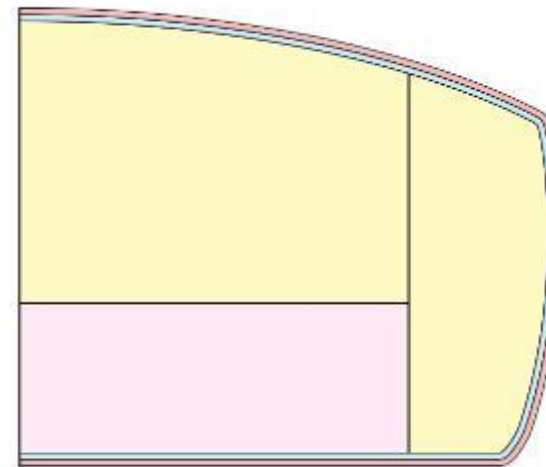

SEAT CUSHIONS SECTION

## Comfort

- Comfort is guaranteed by generous and enveloping cushions which are not only soft and relaxing but also developed to be long-lasting
- At the end of its life cycle, each single element can be separated and disposed of following the most suitable path for each material



# Mirabell Collection | Dimensions



→ MIRABELL 2 Seater Sofa

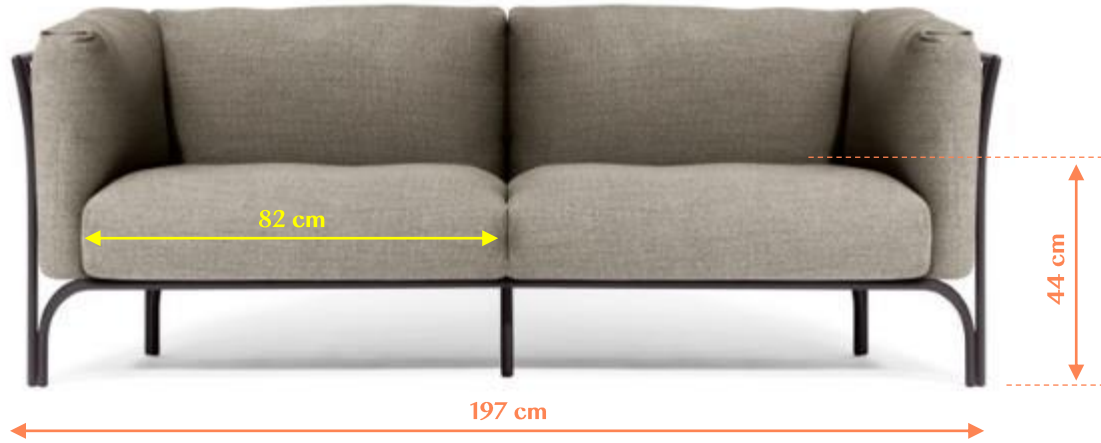

→ MIRABELL Large 2-Seater Sofa

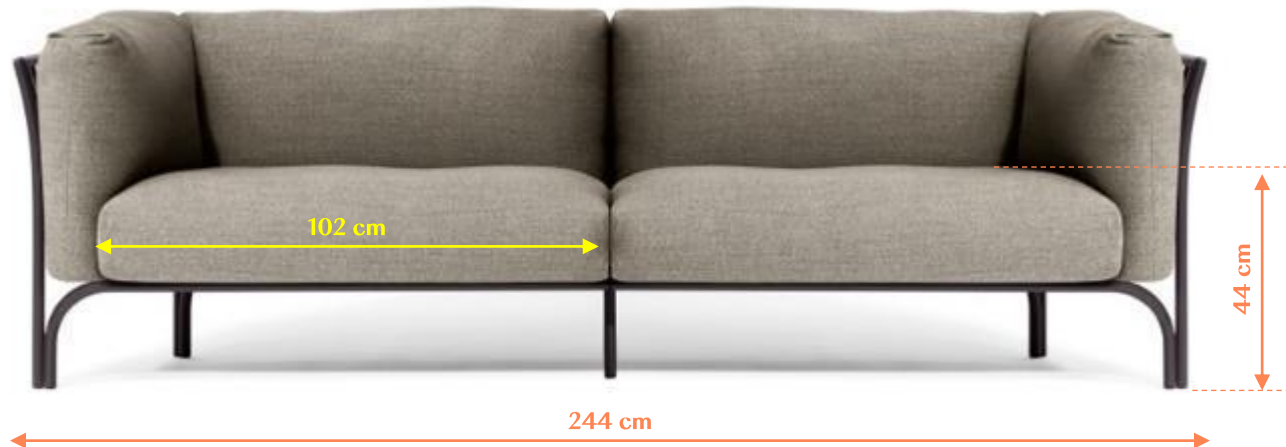

→ LOGO  
polyester label  
on the armrest



# Mirabell Collection | Coffee tables



## Solidity and color

→ The collection is enriched by two round low tables:

Ø80x42h cm e Ø110x32h cm

→ They offer multiple **support solutions in two different materials** for the tops: glazed lava stone in three colors and aluminium in one color Basalto:

→ The **combination of the two different materials**, glazed lava stone and aluminium, in different heights is interesting.



### GLAZED LAVA STONE COLORS



BLU PIGNA



YELLOW SINAPA



GRAY FERRANTE

### ALUMINIUM TOP COLOR

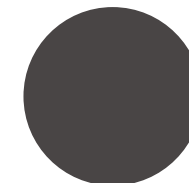

BASALTO

# Mirabell Collection | Coffee tables

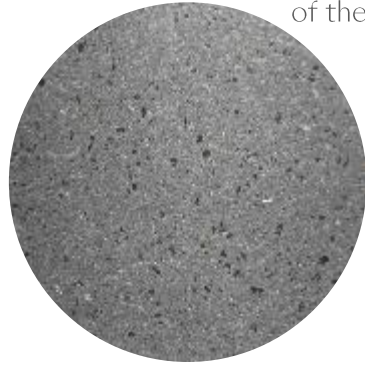

Detail of the bottom  
of the lava stone top



→ The structure of the tables follows the lines of the collection and it is in aluminium in a Basalto color like the structure of the sofas

- The texture of the lava stone is characterized by **dense non-homogeneous dots** which enhances its three-dimensionality and naturalness.
- The **glazed surface, available in the three colors** is obtained with a special glass powder which come from recycling discarded TV monitors and PCs.

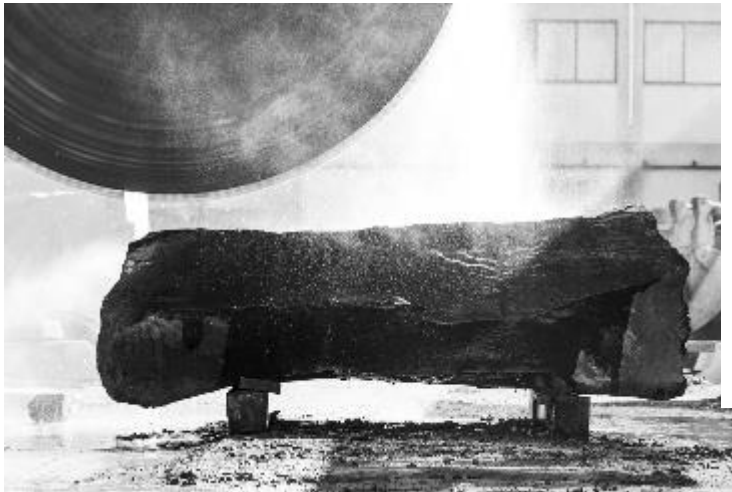

## Glazed lava stone

- The magma of Etna, a volcano still active in Sicily, reaches a temperature of 1300° during an eruption, solidifying and becoming black lava.
- Over the years, some lava flows become quarries. **The material currently extracted come from an eruption of the XVII century.**
- The blocks of lava stone are extracted from here and cut into gray slabs.
- To obtain the exclusive Poltrona Frau colors, a pigmented powder obtained from the recycling of **glass from old discarded TV and PC monitors** is applied to the gray slab.



# Mirabell Collection | Materials



## UPHOLSTERY\*

- Pelle Frau Outdoor
- Fabric Outdoor Cat.A
- Fabric Outdoor Cat.B
- C.O.M



**FOTO:**  
Large 2-Seater Sofa  
Upholstery: Mesh 94/1 Beige  
Frame: Basalto

## FRAME

- Aluminium in a BASALTO color

## TOP

- Glazed Lava Stone in three colors:
  - BLU PIGNA
  - GRAY FERRANTE
  - YELLOW SINAPA
- Aluminium in a BASALTO color



## FRAME

- Aluminium in a BASALTO color

**PHOTO:**  
Mirabell Ø110x32  
Top: Blu Pigna  
Frame: Basalto

## NOTA

\* Removable upholstery



# Mirabell Collection | Technical Specifications



## 2 SEATER SOFA

## LARGE 2-SEATER SOFA

## COFFEE TABLES

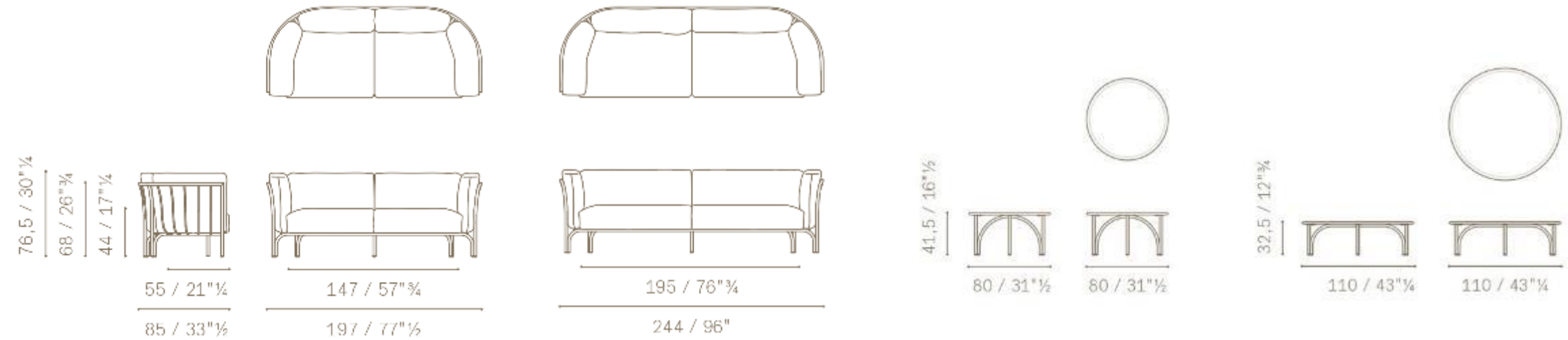

**FRAME:** in powder-coated aluminum tubes with an embossed BASALTO color finish (RAL 8019).

**CAPS:** in plastic inserted into the structure. Additional clip-on tips in plastic and synthetic material suitable for the outdoors are supplied.

**SEAT, BACKREST, ARMREST CUSHIONS:** posed in the frame, each of them is tied to the structure by straps which allow quick positioning and removal.

**SEAT CUSHION:** made of draining material. The padding is in open cell polyurethane with different densities and polypropylene fabric. In the non-visible lower part there is a black polyester non-slip fabric.

**BACKREST CUSHION AND ARMREST CUSHION:** with padding made of polyester fiber that simulates goose-down and lining in water-repellent polyester, internally there is an insert in expanded polyurethane.

**FRAME:** in powder-coated aluminum tubs with an embossed BASALTO color finish (RAL 8019).

**ALUMINUM TOP:** powder coated with embossed finish in basalt color finish (RAL 8019)

**LAVA STONE TOP:** in glazed lava stone color:

- Blue Pine Cone
- Gray Ferrante
- Yellow Sinapa

**CAPS:** in plastic inserted into the structure. Additional clip-on tips in plastic and synthetic material suitable for the outdoors are supplied.

A close-up photograph of the backrest of a chair, showing a light-colored, textured woven fabric stretched over a white frame. The frame consists of a curved top rail and vertical slats.

# Solaria Collection

Design: Ludovica + Roberto Palomba

**RANGE EXTENSION**

# Range Extension | Solaria Collection – Product Philosophy



«Solaria collection grows with **the arrival of a table and a chair with a transversal design, elegant, light and rich in materials.** The Solaria chair maintains the evocative theme of weaving, which is also reflected in an original way in the design of the sofa. As for the table, wooden slats give a warm and material touch, clearly inspired by the world of nature. The cast aluminum structures are finely crafted, adding further refinement to the collection.»

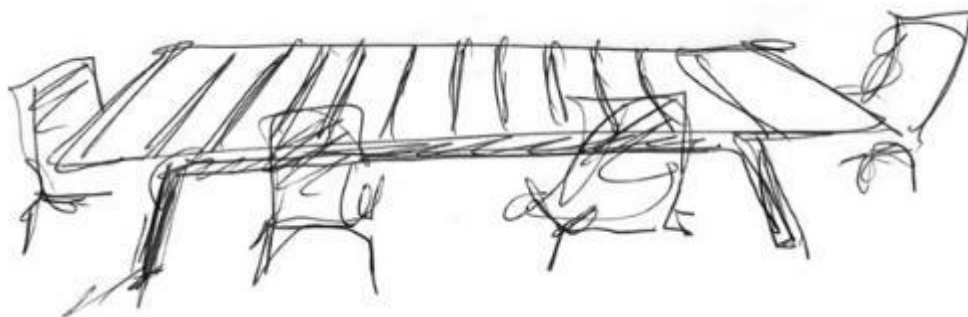

# Range Extension | Solaria Collection – Stackable Chair



## Lightness and functionality

- The new chair reinterprets the characteristics and details of the Solaria Collection, **the hand-woven weaving with its play of light and shadow.**
- **Stackable and extremely light** because it is entirely made of aluminium, it represents the key element of the dining area together with the new dining tables.
- The **hand-woven backrest is visually transparent** and light while the seat is characterized by a dense weave to ensure comfort and stability.



# Range Extension | Solaria Collection – Stackable Chair



→ The aluminum casting designed to create the leg joint gives fluidity to the lines of the chair and guarantees stability for residential and contract uses.



- The aluminum tube of the seat rises without interruption, tapering to the backrest to lighten the volumes of the chair.
- The “naked” tube on the top of the backrest, recalls the origins of woven bar chairs

→ The seat, precisely crafted with a hand-woven weave, can be further enriched by a cushion available in outdoor fabric or leather.



# Range Extension | Stackable Chair – Details



## WEAVING\*

- Ecrú Cord
- Taupe Cord



ECRÚ CORD +  
GESSO CORD



TAUPE CORD +  
BASALTO FRAME

## NOTE:

\* The weaving is always done tone on tone with the frame

\*\* Removable upholstery



## BRANDING

Stainless steel plate

## FRAME

- Gesso painted aluminium
- Basalto painted aluminium

## OPTIONAL CUSHION\*\*

- Pelle Frau Outdoor
- Fabric Outdoor Cat.A
- Fabric Outdoor Cat.B
- C.O.M

# Range Extension | Stackable Chair – Technical Specifications

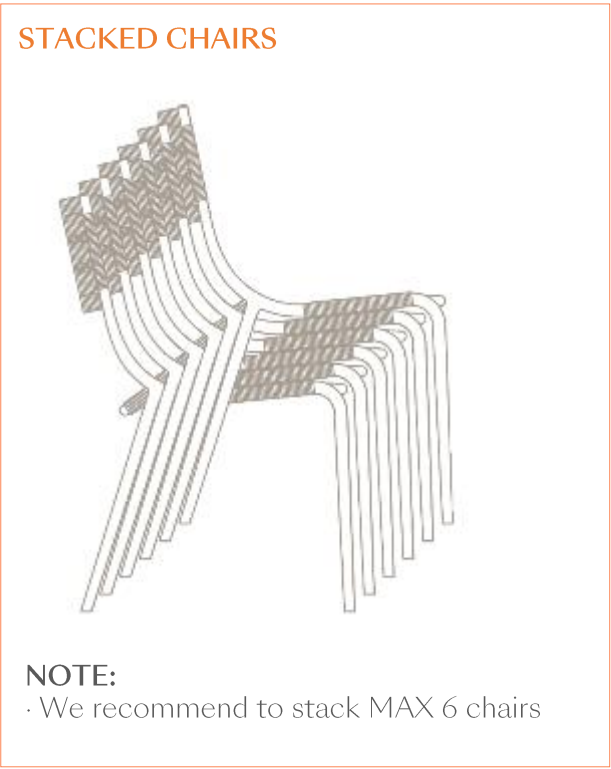
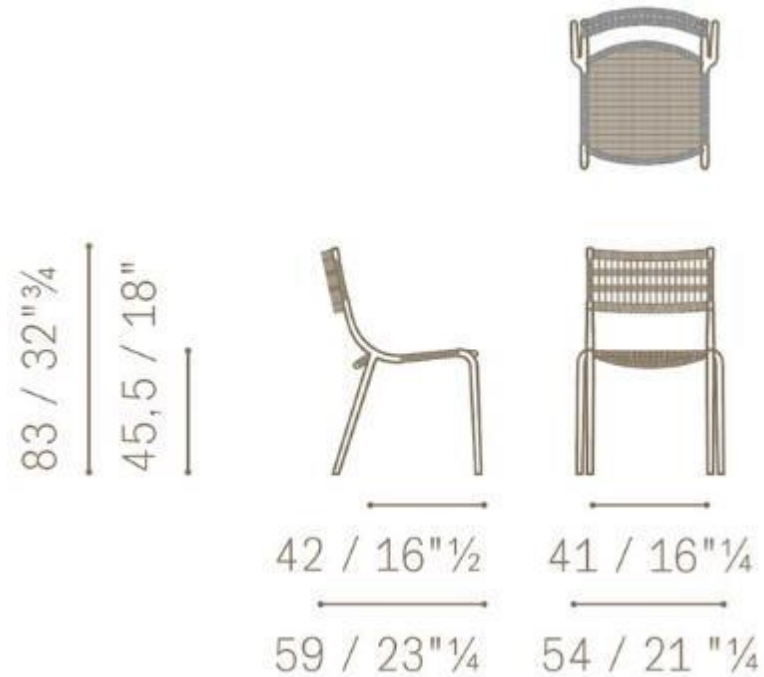

**FRAME:** made of cast aluminum onto which conical tubes for the legs and backrest are inserted. The chair is available in two configurations:

- Gesso frame + Ecrù cord
- Basalto frame + Taupe cord

All metal elements are painted with epoxy powders in GESSO or BASALTO color.

A particular weave with polypropylene rope forms the backrest and seat supports.

The same rope is used to wrap the frame elements.

The legs end with black nylon caps (basalto frame) or natural nylon (gesso frame).

# Range Extension | Solaria Collection – Tables

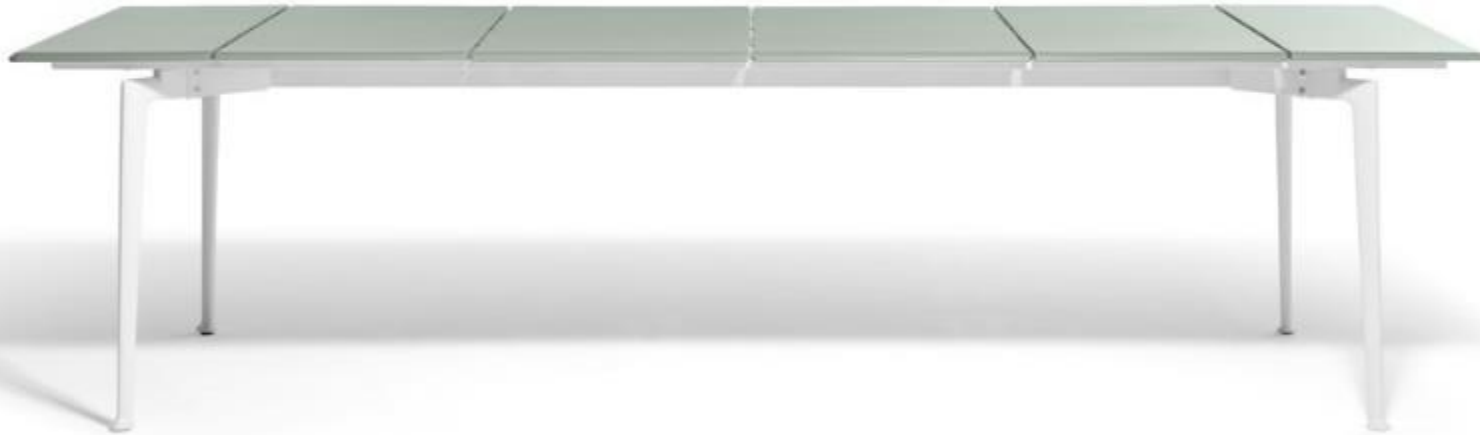

## Lightness and functionality

- The range of Solaria tables is rich and various in size and materials.
- The structure is sturdy due to **the use of stainless steel and aluminum** while the tops can be in the warm shades of teak or glazed stoneware in two colors.
- The possibility of combining the two colors of the structures with the two materials in different shades allows you **to create different chromatic moods suitable for every type of needs.**



# Range Extension | Solaria Collection – Tables



→ The top made with slats in different widths move the **surface** of the tables and is an aesthetic choice present on both the teak and glazed stoneware versions.



→ The stoneware slats are wider than the teak ones to ensure stability and avoid breakages.

→ **Glazed stoneware is recommended for customers who do not like teak and want a surface that is resistant to dirt and natural color changes.**

→ The **Ø180 round table in the teak version is also available with a central hole** for inserting an umbrella.



# Range Extension | Solaria Collection – Tables



→ The tops are available in **Pale Green or Pale Brown glazed stoneware or teak in a natural finish** but the tilted edge section is present on both materials.



→ **The characteristic leg of the Solaria tables** guarantees stable support on all types of ground or flooring and is equipped with an adjustable foot.

→ **The leg is a single aluminum casting** that fits into a solid stainless-steel frame

→ The special silhouette of the leg was designed to **increase the detachment from the top** and make the volumes lighter and more airy.

# Range Extension | Solaria Collection – Tables

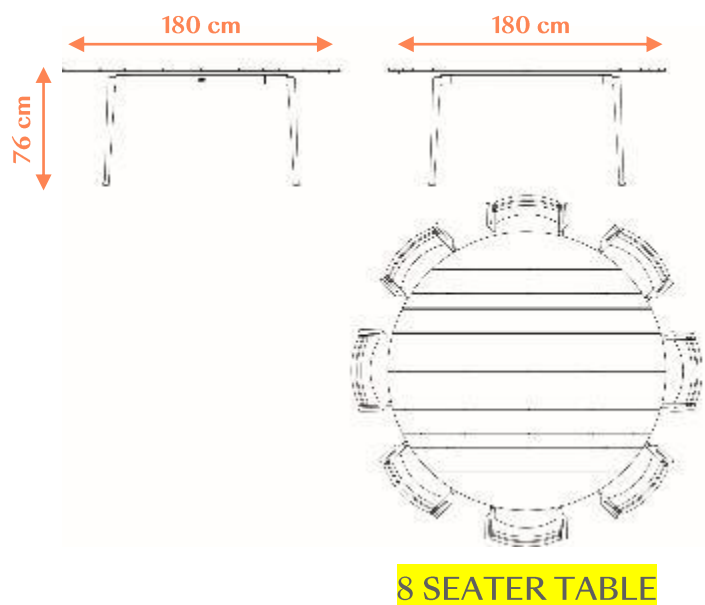
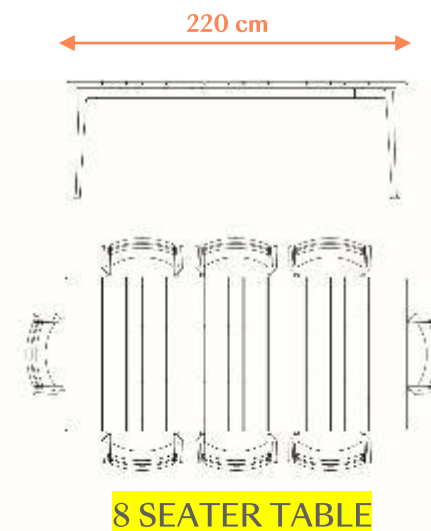
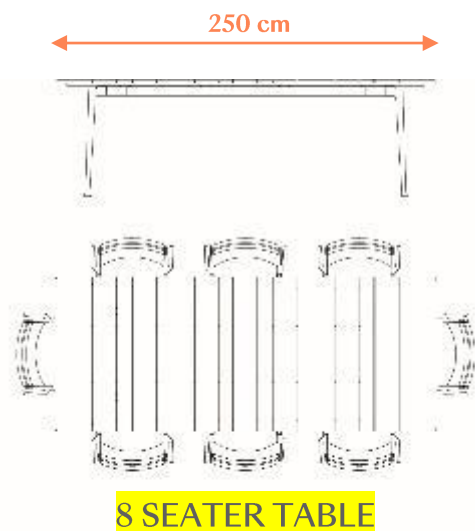
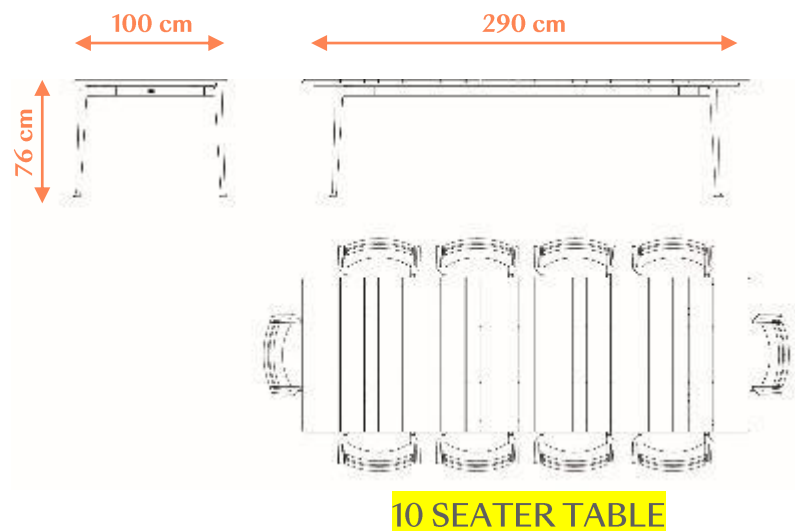

**NOTE:**  
· Top view of teak table tops

**MATERIALS**

**TOP**

- NATURAL TEAK
- PALE BROWN
- PALE GREEN

**FRAME**

- GISSO
- BASALTO

# Range Extension | Solaria Collection – Armchair



## Dynamic and minimal style

- Solaria armchairs intended to evoke the cultured interpretation of Scandinavian design, expressed in its minimal style and lightness.
- The armchair represents the element of verticality in the horizontal rhythm of Solaria, visually transparent thanks to its interlacing motif.



# Range Extension | Solaria Collection – Armchair



HIGH-BACK ARMCHAIR (2021)

-30 cm



ARMCHAIR (2024)

## New low-back version

- New lower backrest (**-30cm**) to increase transversality and use in different layouts
- The **new version is lighter and more compact** than the one with the high backrest
- The customer can choose to use the seat cushion and headrest
- As for the high-back version, the armchair is available with armrests

# Range Extension | Solaria Collection – Armchair



→ The seat and back are characterized by a weaving of rope col. Ecrù which is more compact in the upper and lower part of the backrest and seat.



→ The armchair is available with or without armrests. The armrest is a stainless steel element that is fixed to the structure and is characterized by a rope weave.



→ The woven seat of the armchair stand on a base with cast aluminum legs. All metal parts are powder coated with a GESSO-coloured embossed finish.

# Range Extension | Solaria Collection – Armchair



## UPHOLSTERY OPTIONAL CUSHIONS\*

- Pelle Frau Outdoor
- Fabric Outdoor Cat.A
- Fabric Outdoor Cat.B
- C.O.M



→ At the customer's choice, the possibility of using the seat cushion or the seat cushion in combination with the headrest.

## NOTE

\* Removable upholstery

# Range Extension | Solaria Armchairs – Materials

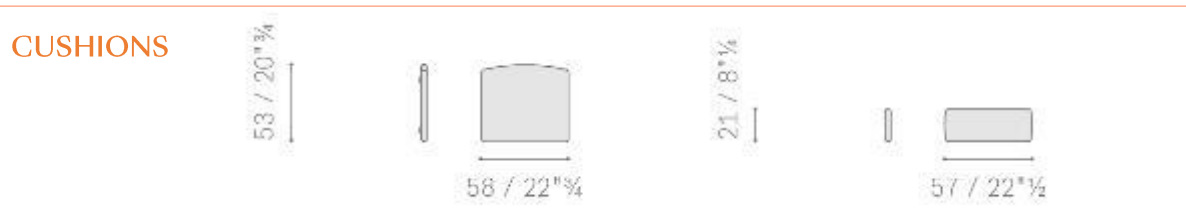
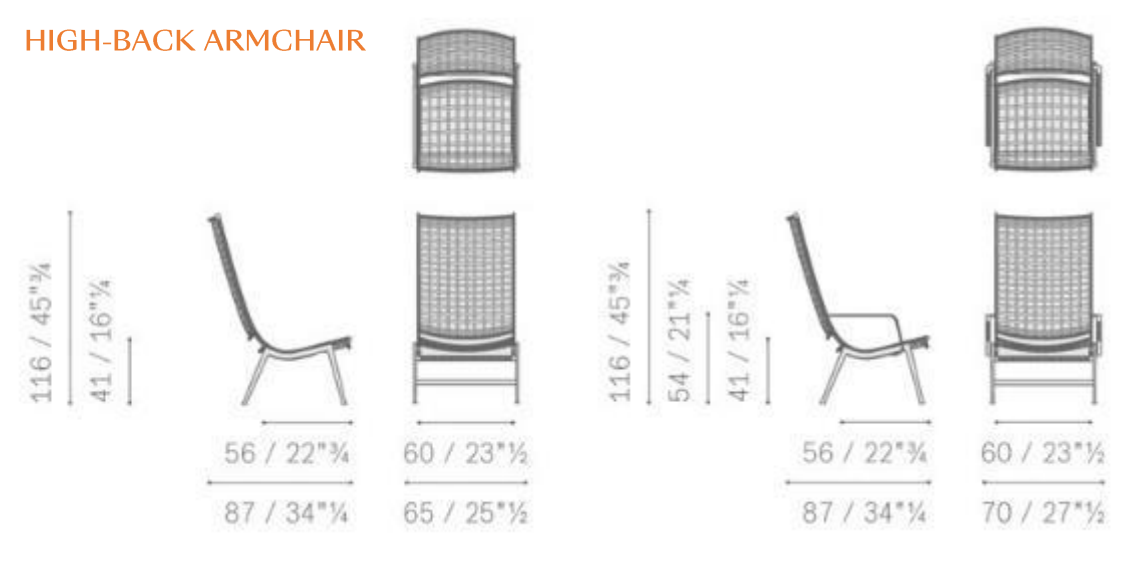
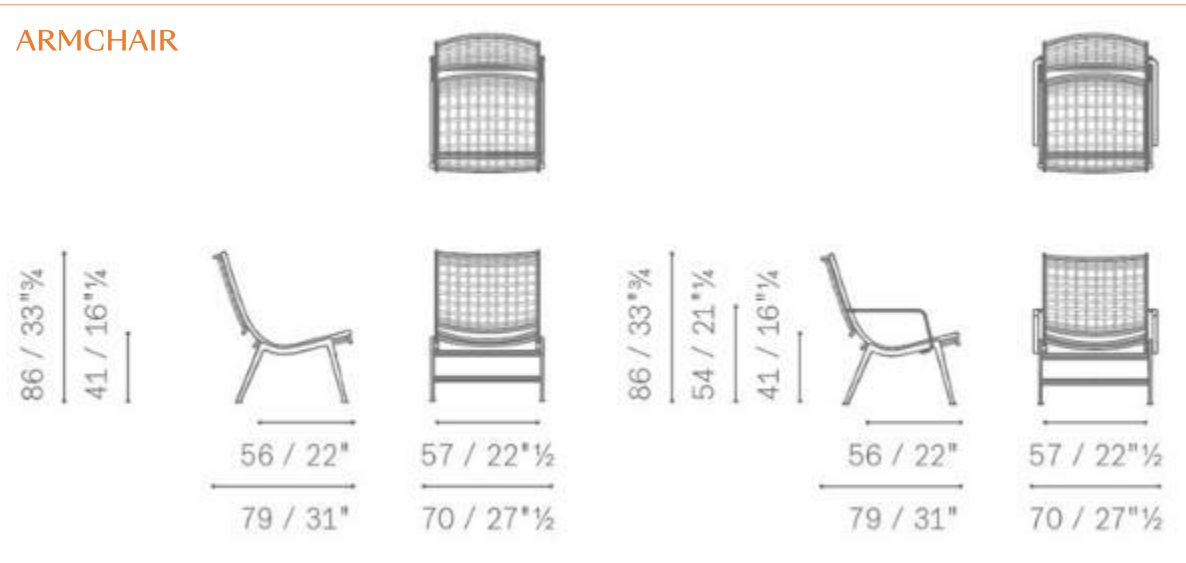

**FRAME:** In stainless steel painted with epoxy powder in GESSO color (RAL 9002).

**ARMRESTS** (in the model that includes them): In stainless steel in the same finish as the frame and covered with Ecrù-coloured polypropylene cord.

**BACKREST AND SEAT:** Characterized by a particular weave with Ecrù-coloured polypropylene rope.

**BASE:** In cast aluminum painted with epoxy powder in GESSO color (RAL 9002).

**CAPS:** In black nylon.

**CUSHIONS:** Not included in the price. The optional cushions are fixed directly to the weaving using aluminum elements painted with epoxy powders in the GESSO color RAL 9002. Models: Headrest cushion and Seat cushion

**COMPOSITION:** Made of polyester fiber that simulates down and a water-repellent polyester cover.

**REMOVABLE UPHOLSTERY:** Available





# Sparkler Collection

Design: Kensaku Oshiro

RANGE EXTENSION

# Range Extension | Sparkler



TAUPE (2021)



RUST (2024)



ECRÚ (2024)

## New colors

- The iconic Sparkler lanterns are now available in three colors to adapt even better to different environments.
- The colors remain the same of the Lepli family in the same rope and frame combinations:

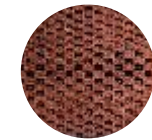

RUST  
CORD



BASALTO  
FRAME

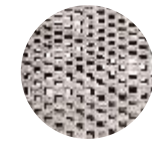

ECRÚ  
CORD

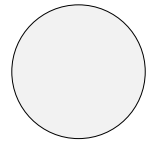

GESSO  
FRAME

# Ampliamenti di gamma | Sparkler

SMALL FLOOR LANTERN



FLOOR SUSPENSION KIT



SMALL CEILING SUSPENSION LANTERN



CEILING SUSPENSION KIT



- The **small lantern** is equipped with two accessories, a **2,5m cord with hook** to hang the lantern from the ceiling and **an arch support** from the height of 130cm, they increase the possibilities to use the lamps, changing their perception: from a floor element to more vertical and airy structures.
- Now the two optional kits also have a new color and a **new logo will be introduced starting from the new colors.**







# Cestlavie Outdoor

Design: GamFratesi



# Cestlavie Outdoor | Design by GamFratesi

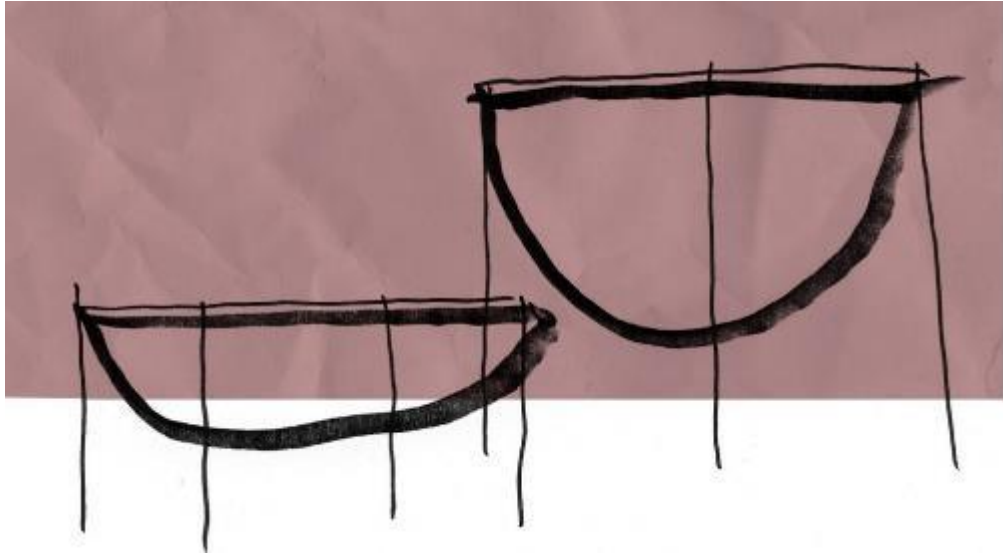

«We have re-interpreted a traditional sewing basket that can contain various objects in an informal way. The reference is to the classic wicker basket, and expresses to the maximum its intrinsic value which is part of the Poltrona Frau tradition. In fact, the basket is finely woven and requires careful craftsmanship.»

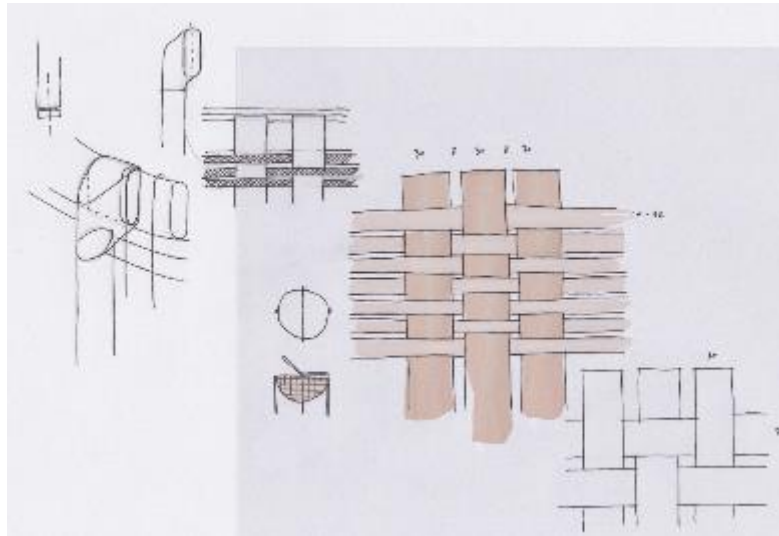

# Cestlavie Outdoor | Details



Cestlavie Ø46x50h  
Weaving: Ecrú  
Frame: Gesso



Cestlavie Ø88x44h  
Weaving: Taupe  
Frame: Basalto

→ Two available sizes for these items, one as a protagonist in the center of a layout or close to a large modular sofa and a smaller and taller one which, as a satellite, can be placed close an armchair or a sunbed.

→ Half coffee table, half container, **Cestlavie is a collection** of elegant and precious objects that now can **enrich outdoor spaces**, too.

→ The manual weaving process used for the leather has been transferred to the cord used for the other products in the outdoor collection.

→ The shapes and dimensions are exactly the same of the indoor versions to guarantee a perfect trait d'union between the interior and exterior of the home or contract environment.

→ Available combinations are:



TAUPE  
CORD



BASALTO  
FRAME



ECRÚ  
CORD

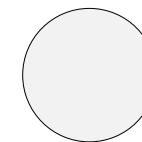

GESO  
FRAME

# Cestlavie Outdoor | Details



→ The aluminum frame is integrated into the design of the basket, maximizing the manual workmanship of the weaving



→ Cestlavie Outdoor can be enriched with two optionals:

- a) A **removable tray** with a function of lid or table made of powder-coated aluminium:
  - GESSO with a handle in Pelle Frau Outdoor 21 Amianto
  - BASALTO with a handle in Pelle Frau Outdoor 26 Topo
  
- b) An **ice-holder** to contain and keep fresh bottles at the side of a sofa or close the poolside **is available only for the small version of the basket**

→ The special feet ensure stability on any type of ground or surface.



# New Outdoor Upholsteries

- Pelle Frau® Outdoor
- Outdoor Fabric Collection 2024



# New Outdoor Upholsteries | Pelle Frau® Outdoor



→ The color palette:

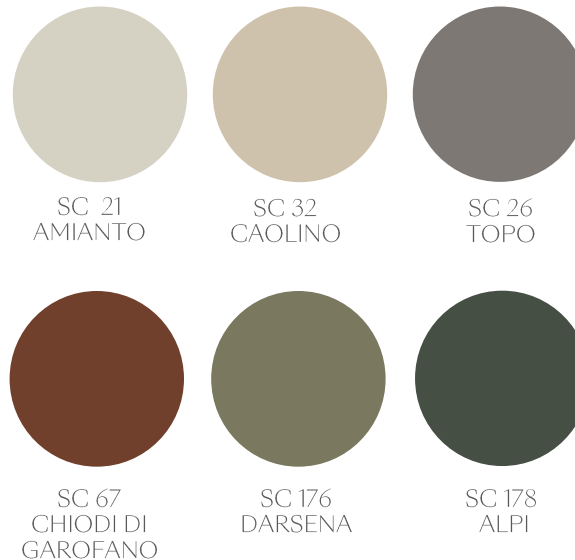

## A leather with incredible performance

- Its surface, pleasant to the touch and breathable, can pass severe tests for outdoor and extreme conditions.
- UV resistant.
- Chlorine and salted Water resistant.
- Resistant to prolonged humidity, mold and bacteria.
- Traditional tanning also called mineral.
- Selection of 6 ColorSphere shades that better match the mood of finishes and materials of the Boundless Living collections by Poltrona Frau.

→ Upholstery available for products:



**SOLARIA**  
- Armchair  
- High-back Arm.  
- Chair



**SOUVENIR D'ITALIE**  
- 2 seater sofa  
- Large 2 seater sofa



**THE SECRET GARDEN**  
- Small armchair  
- Armchair  
- 2 seater sofa  
- Sunbed



**MIRABELL**  
- 2 seater sofa  
- Large 2 seater sofa



**DECORATIVE CUSHIONS**  
- 54x47 cm  
- 47x47 cm  
- 46x22 cm

# New Outdoor Upholsteries | Outdoor Fabric Collection 2024



→ The color palette:



RUST



SNOW

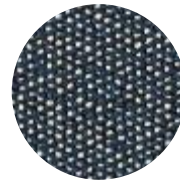

NAVY

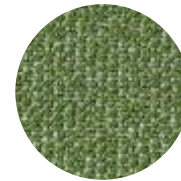

GARDEN

## Jaspè

- Jasper is a speckled fabric, thanks to the use of fancy yarns. Its characteristic is due to the threads composed of 2/3 colored elements that give different shades and an irregular appearance.
- 4 colors designed to match with Quadretto fabric.

| Composition (%)                         | widht (cm) | weight (g/mtl)       | martindale (RUBS) | pilling | type of dying | BS 5852            | TB 117 | Category |
|---|------------|----------------------|-------------------|---------|---------------|--------------------|--------|----------|
| Solution dyed polypropylene - Polyester | 138/140    | 590 g/m <sup>2</sup> | 80000             | 4/5     | yarn dyed     | pass only Source 0 | PASS   | B        |

# New Outdoor Upholsteries | Outdoor Fabric Collection 2024



→ The colors palette:



BROWN

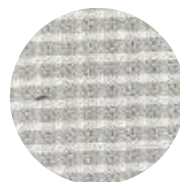

LIGHT GREY



BLUE



GREEN

## Quadretto

- The textured plain fabric is combined with a two-tone decorative fabric with a fresh checkered pattern.
- Fabric made of jacquard loom composed of natural hemp fibers for indoor and outdoor use.
- 4 colors designed to match with Jaspè fabric.

| Composition (%)                    | widht (cm) | weight (g/mtl) | martindale (RUBS) | pilling | type of dying | BS 5852 | TB 117 | Category |
|------------------------------------|------------|----------------|-------------------|---------|---------------|---------|--------|----------|
| 80 Hemp - 20 solution dyed acrylic | 140        | 805 gr/mtl     | 30000             | 4/5     | yarn dyed     | PASS    | PASS   | A        |

# New Outdoor Upholsteries | Outdoor Fabric Collection 2024



→ Existing colors:

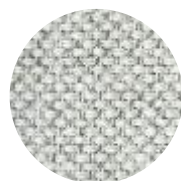

93/1  
BIANCO



90  
GRIGIO



94/1  
BEIGE

→ New color:



5 NATURALE

## Mesh

→ Three-dimensional fabric inspired by the knitted fabrics.

| Composition (%) | widht (cm) | weight (g/mtl)       | martindale (RUBS) | pilling | type of dying | BS 5852            | TB 117 | Category |
|-----------------|------------|----------------------|-------------------|---------|---------------|--------------------|--------|----------|
| 100% PP         | 138/140    | 830 g/m <sup>2</sup> | 60000             | 4/5     | yarn dyed     | pass only Source 0 | PASS   | <b>B</b> |



---

Manzoni 30 set up

---



## Set up | *project areas\_* showroom + outdoor courtyards



### Showroom + outdoor courtyards

About 2000 square meters of exhibition space with main focuses on the new 2024 collection, the Beautilities collection, three dedicated areas for special presentations, and expansion of the outdoor collection with an outdoor lounge area



-  Poltrona Frau
-  Corti esterne Poltrona Frau
-  Ceccotti Collezioni

## Set up | *project areas \_ showroom floor -1*



### Showroom floor -1

Poltrona Frau will host, on the -1 floor of the showroom, an area dedicated to Buzzi Space, a company within the Haworth Group

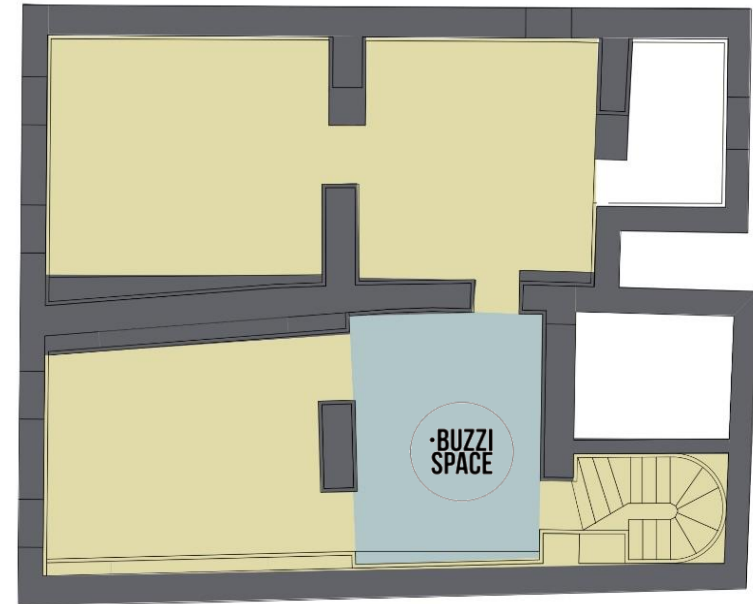

-  Poltrona Frau
-  Buzzi Space
-  Aree Tecniche

## Set up | *project areas \_ lounge + terrace*



### Lounge + terrazza

600 square meters including technical areas, lounge, and terrace.  
Approximately 150 seats available to accommodate clients and meet architects and designers.

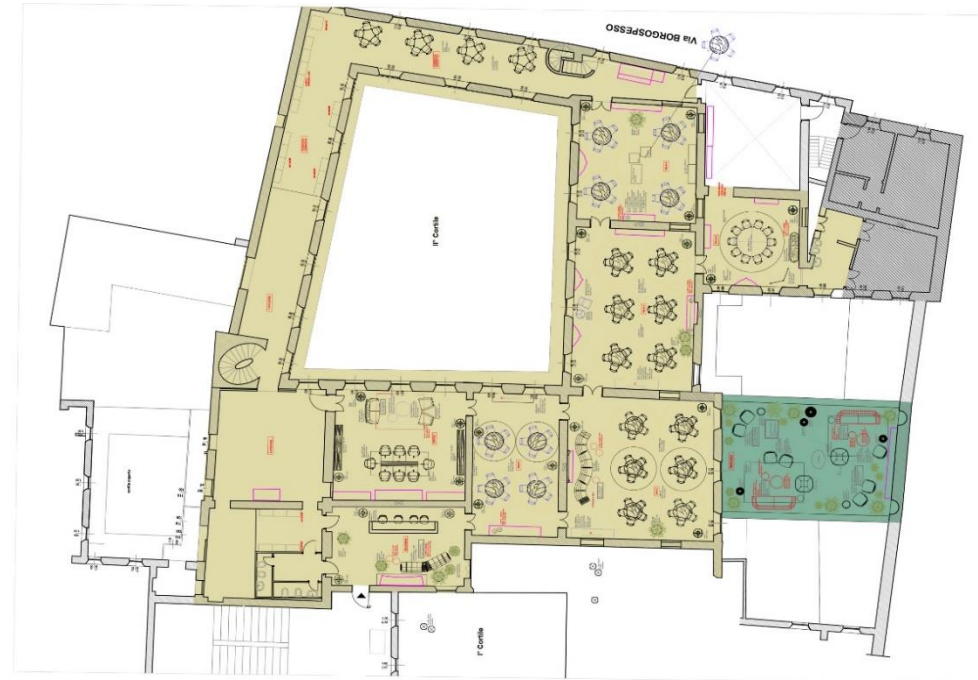

 Area Lounge interna

 Area Lounge esterna/terrazza



# IMAGINE

"Imagination makes possible what does not exist, and this happens through the creative act. Imagining for Poltrona Frau means continuing to envision living spaces, shared spaces, objects to interact with, to feel good with those around us, or simply to relax and reflect."

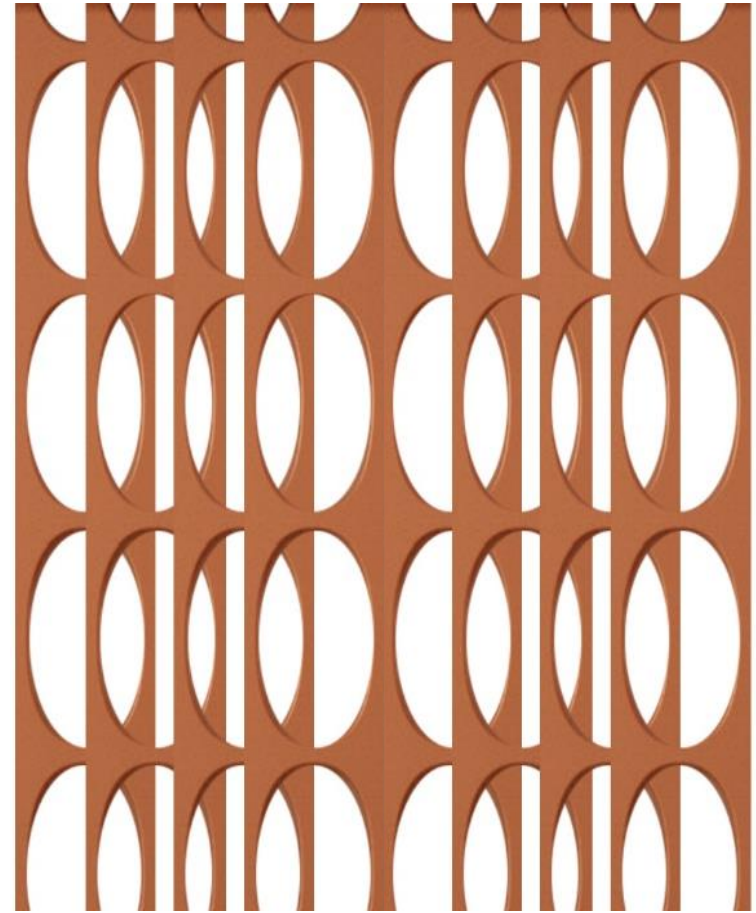

## Set up | *Project\_ creativity + space Design*



### **Creativity + Space Design :**

- Simona Cremascoli
- Studio Brigolin Baschera

Once again, this year, the collaboration with Studio Brigolin Baschera for the architectural aspects of the spaces has been confirmed, as well as the collaboration with Simona Cremascoli, Trend Scouting and Styling, for the selection of colours, finishes, materials, and decoration.



Studio Brigolin Baschera



Simona Cremascoli, Trend Scouting and Styling

# Set up | *project areas* \_ *building facade + windows*

## Building facade + windows

Characterization of the facade on Via Manzoni with 2 vertical banners and totems to signal the showroom activities in the courtyards of Palazzo Gallarati Scotti; window stickers on the shop window with the event's logo.



## Set up | *project areas\_ concept set up*

### Glossy and matte finishes and overlays.

Vertical elements, with voids and solids, glossy and matte surfaces with tone-on-tone shades or strongly iconic new colours. The voids and solids, together with the overlays, soften the spaces, and the interplay of glossy and matte enriches the environments, making the surfaces more three-dimensional.

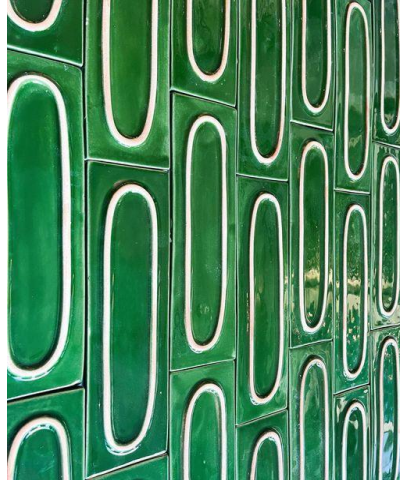



# Set up | *project areas* \_ *color palette showroom*



## Color palette

This year, once again, a study has been conducted on colours, finishes, and materials in the showroom to emphasize the new leather colours, the new fabrics, and to characterize the spaces in different ways, allowing visitors to discover a different and always new atmosphere in each environment



# Set up | *project areas* \_ *main areas of intervention*



## Main areas of intervention

All areas of the showroom, both internally and externally, have been uniformly characterized by the intervention of set-up.



# Set up | project areas \_ set up project elements

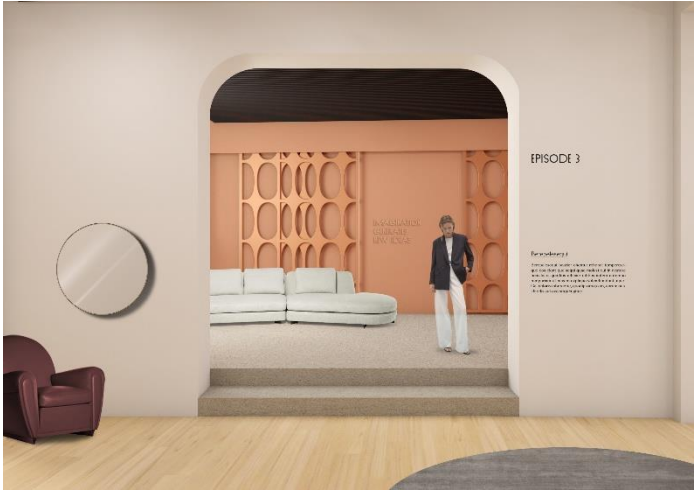

## Set up | project areas \_ Beautilities gallery



### Beautilities gallery

This year, emphasis has once again been placed on the Beautilities collection and its expanded range, with a new characterization of the gallery.

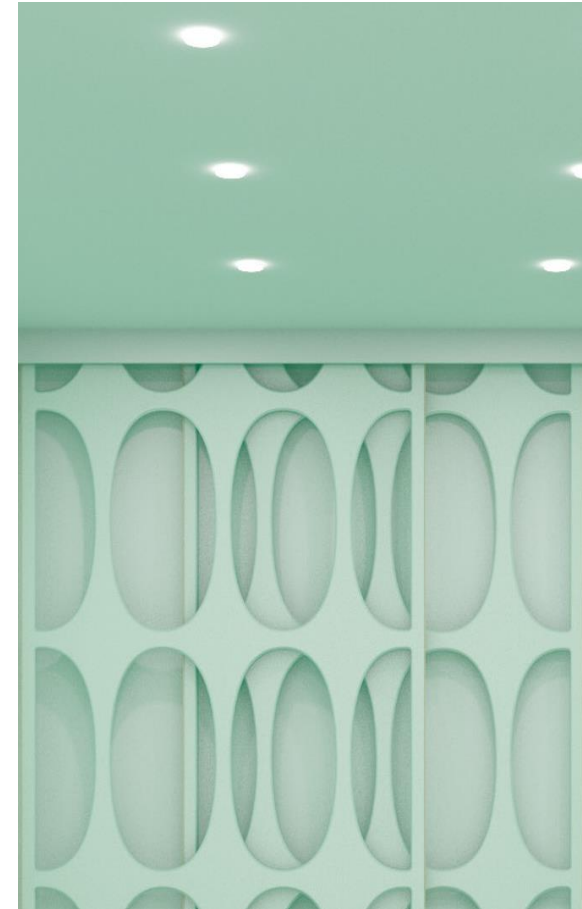



# Set up | project areas \_ tribute to 100 years poster



## Tribute to 100 years poster

At the beginning of the gallery, a wall dedicated to celebrating the 100 years of the graphic poster designed by Mario Nanni for Poltrona Frau in 1924.

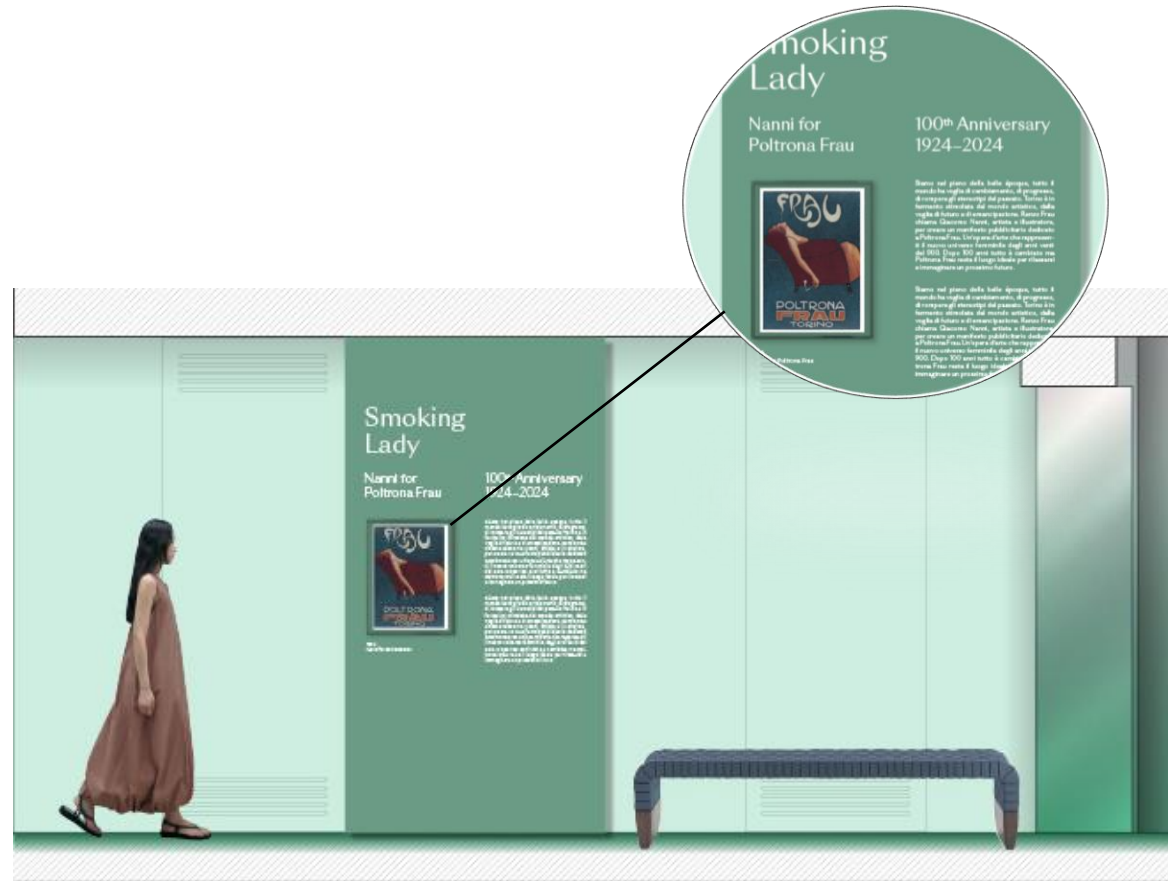

## Set up | *project areas* \_ *art to support*



### Art to support

To further emphasize certain spaces within the showroom and enhance the furnishings, two contemporary artists have been engaged to create specific artworks tailored for Poltrona Frau.



## Set up | *project areas* \_ *art to support*



### Art to support

"Two are the areas of the showroom characterized by artistic intervention: the first in the area on Via Manzoni, the second in the room adorned with frescoes and featuring a fireplace



---

Set up | *project areas* \_ *art to support*

**Art to support**

Daniele Papuli





# Set up | *project areas* \_ *art to support*

## Art to support

Benedetta Mori Ubaldini

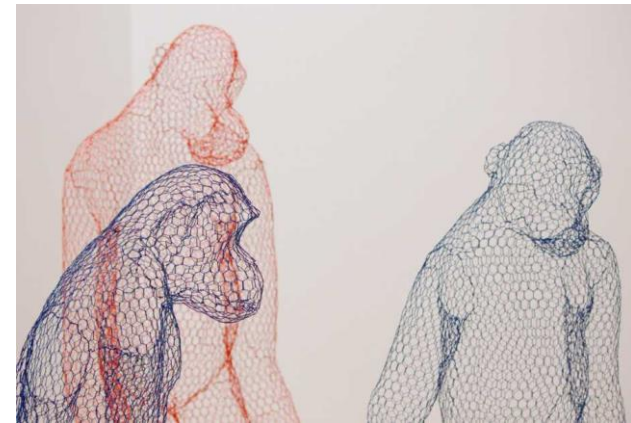
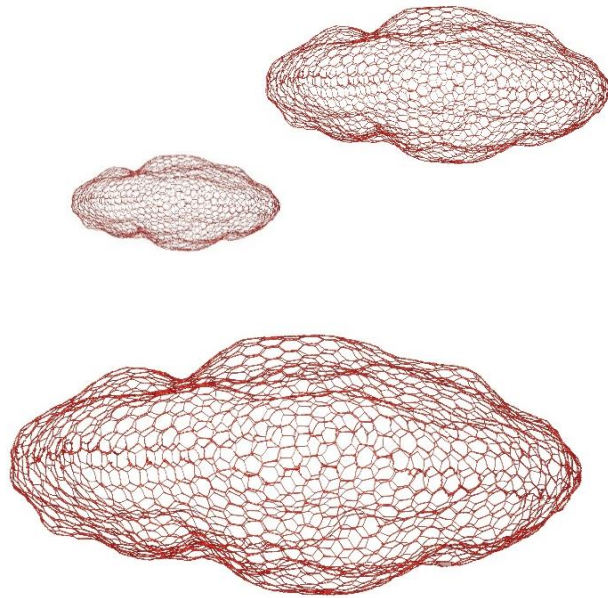

## Set up | *project areas \_ dedicate spaces*

### Dedicate spaces

Within the showroom, two areas have been designated to emphasize and give greater emphasis to two particular projects.



## Set up | *project areas \_ dedicate space \_Ozwald Boateng*



### Dedicate space \_Ozwald Boateng

A dedicated area of approximately 80 square meters to showcase the Poltrona Frau project with Ozwald Boateng. Presentation of the extension of the furniture collection, wallpapers, carpets, and a dedicated display for the OB Beautilities.

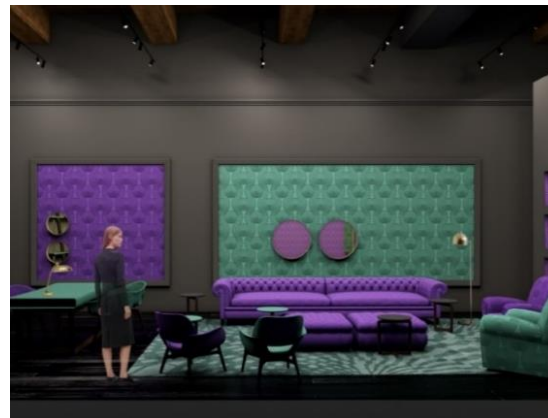

## Set up | *project areas* \_ *dedicate space* \_ *Home cinema*



### **Dedicate space \_ Home cinema**

To better showcase the project of the new Pillow Cinema seat, it was decided to dedicate a room in the showroom to a home cinema experience, thanks also to the collaboration with the brand Bang & Olufsen, which provided the necessary technology for the audio and video system





# Set up | *project areas* \_ outdoor courtyards



## Outdoor courtyards

The outdoor courtyards of the palace will be set up to emphasize the outdoor collection, its extension, and will host the large outdoor lounge as last year. Additionally, we will have a space dedicated to a special presence resulting from a collaboration with an automotive company.



## Set up | *project areas \_ dedicate space \_ Ferrari*



### Dedicate space

In the main courtyard of the palace, we will host a Ferrari car to showcase the collaboration between the two brands and Poltrona Frau's specific know-how in the automotive sector



## Set up | *project areas* \_ *dedicate space* \_ *Ferrari*



### Dedicate space \_ Ferrari

Model: Roma Spider Atelier – VIN  
288405

Body color: Nero Purosangue

Vehicle interior: Poltrona Frau leather,  
Rosso Giudecca (Giudecca Red)





Thanks